

Wheel Mount MULTIPLE DISC BRAKE



Service Instructions

NOTE:
This service sheet covers
model:
13-587-092

REPAIR KITS (Refer to Page 3 for item numbers)

NUMBER	DESCRIPTION	INCLUDES
12-501-455	Repair Kit	Case Seal (18) Back-up Rings (12 & 15) O-rings (13 & 16) Stator Disc (11) Rotor Disc (10) Return Plate (9) Springs (8) Bearings (3 & 17)

This publication is not subject to any update service. Information contained in this publication was in effect at the time the publication was approved for printing and is subject to change without notice or liability. ZF Off-Highway Solutions Minnesota Inc. reserves the right to revise the information presented or to discontinue the production of parts described at any time.



ZF Off-Highway Solutions Minnesota Inc.
1911 Lee Boulevard / North Mankato, MN U.S.A. 56003
Tel: +1 507 625 6426 **Fax:** +1 507 625 3212

DISASSEMBLY

1. Remove castle nut (1) and key (5) from output end of spline shaft (6).
2. With tapered end of shaft (6) facing down, remove pressure plate (19) from cover (2) by removing four cap screws (20). A suitable holding fixture is useful to keep brake in position.

⚠ CAUTION

Pressure plate is under spring tension of approximately 1361 kgf (3000 lb). The four cap screws should be loosened evenly to relieve this force. If a hydraulic press is available, 1361 kgf (3000 lb) minimum, the pressure plate can be held in position while removing the cap screws.

3. If necessary tap pressure plate (19) with a soft mallet in order to dislodge bearing (17) from shaft (6).
4. Remove case seal (18) from cover (2).
5. Remove bearing (17) from pressure plate (19).
6. Remove piston (14) from pressure plate (19).
7. Remove o-rings (13 & 16) and back-up rings (12 & 15) from piston (14). **NOTE: Be careful not to scratch or mar piston.**
8. Remove stack assembly, consisting of stator (11), rotor (10) and return plate (9) from cover (2).
9. Remove dowel pins (4), springs (8) and spring retainer (7) from cover (2). **NOTE: Not all models use the same number of springs or spring pattern. Record this information for assembly purposes.**
10. Remove shaft (6) by pressing or using a soft mallet on the tapered end of shaft.
11. Remove bearing (3) from shaft (6).

ASSEMBLY

LUBRICATE ALL RUBBER COMPONENTS FROM REPAIR KIT WITH CLEAN TYPE FLUID USED IN THE SYSTEM.

1. Clean all parts thoroughly before assembling.
2. Install new bearing (3) on shaft (6). Be sure bearing contacts shoulder on shaft.
3. Install shaft assembly in cover (2).
4. Install dowel pins (4), spring retainer (7) and new springs (8) in cover (2). **NOTE: Be sure to use the same number of springs and spring pattern as recorded during disassembly.**

5. Install new return plate (9), new rotor disc (10) and new stator disc (11) over dowel pins (4) and spline of shaft (6).

NOTE

Be careful to avoid contaminating friction surfaces with oil as this is a dry design brake.

6. Install new o-rings (13 & 16) and new back-up rings (12 & 15) on piston (14). Note order of o-rings and back-up rings. Be sure o-rings are flat and all twists removed. **NOTE: Be careful not to scratch or mar piston.**
7. Carefully install piston (14) into pressure plate (19). Note direction of piston (14). Be careful not to shear o-rings or back-up rings.
8. Install new bearing (17) in pressure plate (19).
9. Install new case seal (18) in cover (2).
10. Position pressure plate (2) on cover (19) aligning dowel pins (4) with holes in pressure plate. Install cap screws (20) and tighten evenly to draw pressure plate (2) to cover (19). Torque cap screws 74.6-81.4 N·m (55-60 lb·ft). **NOTE: A hydraulic press will simplify installation of pressure plate on cover. Clamp pressure plate in position while tightening the cap screws.**

⚠ CAUTION

If hydrostatic bench testing is performed on the brake assembly, release pressure should not exceed 137.9 bar (2000 PSI) unless two additional bolts are used for supplemental clamping.

Spring Chart

Model	Red Springs (8)	Blue Springs (8)	Yellow Springs (8)
13-587-092	0	0	9

See page 1 for items included in kits.

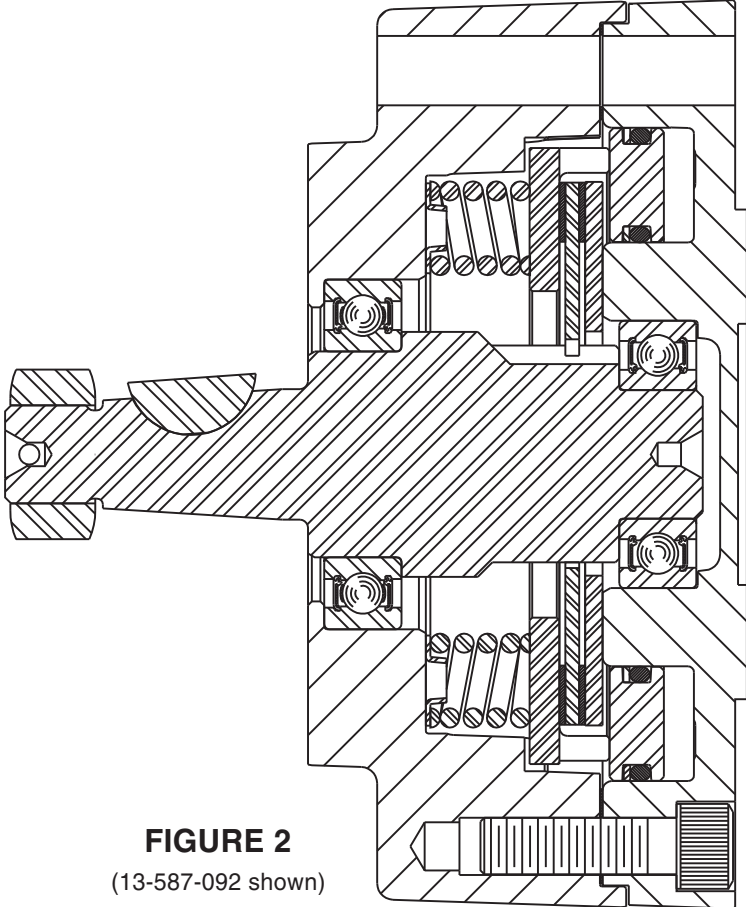
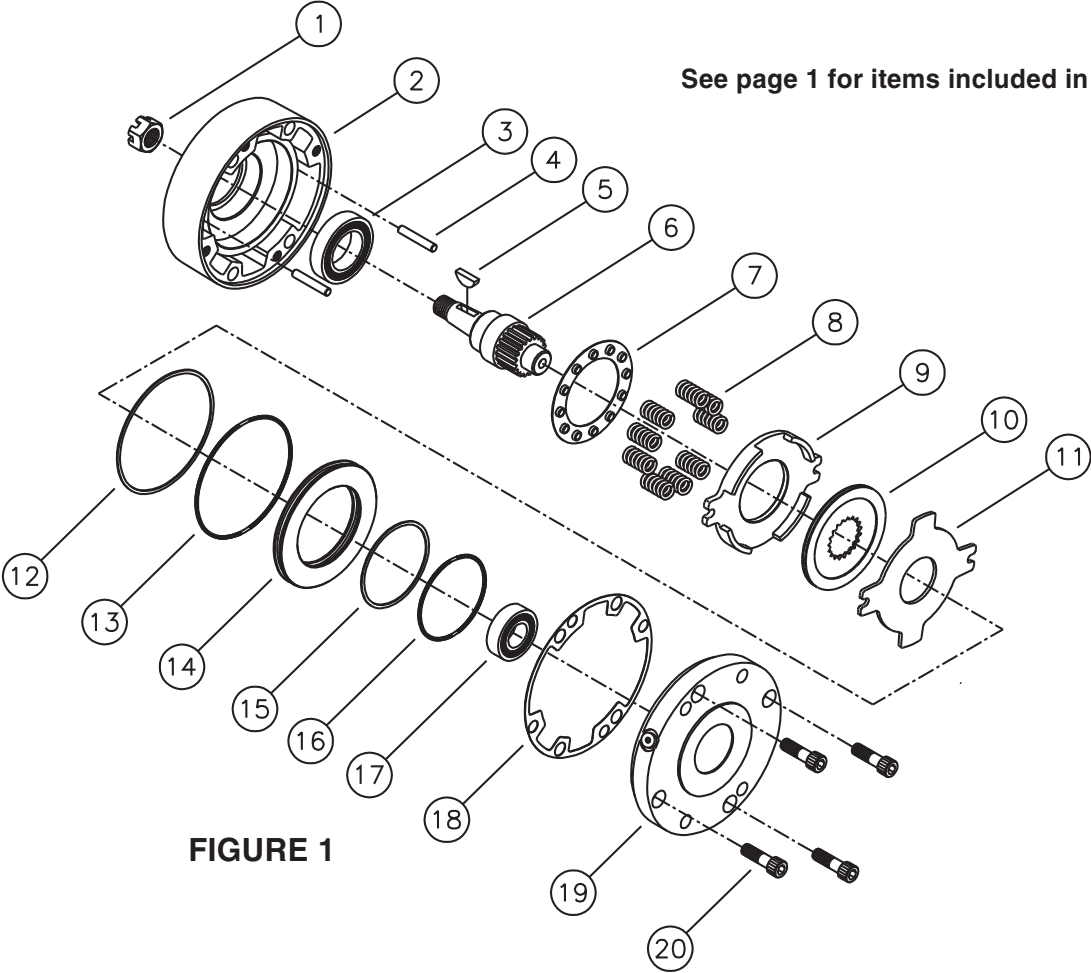

BLEEDING

1. Install brake in system and connect pressure lines.
2. Bleed pressure release section of brake by pressurizing side inlet port and allowing air to escape from top port. Pressure should not exceed 6.89 bar (100 PSI) during bleeding.
3. Apply sufficient pressure to release brake and check for proper operation in system.

SERVICE DIAGNOSIS

PROBLEM	CAUSE	EXPLANATION	ACTION
Brake slips	A. Excessive pressure in hydraulic system	If there is back pressure in the actuation line of the brake, holding torque will be reduced.	Check filters, hose size, restrictions in other hydraulic components.
	B. Oil in brake if designed for dry use	Wet linings generate 67% of the dry torque rating. If the brake has oil in it, check the type of oil hydraulic or gearbox. <ol style="list-style-type: none"> 1. Gearbox oil 2. Hydraulic oil 	Check motor seal. Check piston seals. Note: Internal components will need to be inspected, cleaned and replaced as required.
	C. Disc plates worn	The thickness of the disc stack sets the torque level. A thin stack reduces torque.	Check disc thickness.
	D. Springs broken or have taken a permanent set	Broken or set springs can cause reduced torque - a rare occurrence.	Check release pressure.
Brake drags or runs hot	A. Low actuation pressure	The brake should be pressurized to minimum of 1.38 bar (20 PSI) over the full release pressure under normal operating conditions. Lower pressures will cause the brake to drag thus generating heat.	Place pressure gauge in bleed port & check pressure with system on.
	B. Bearing failure	If the bearing should fail, a large amount of drag can be generated.	Replace bearing.
	C. Oil in brake	Excess fill of oil in sump condition through wet brakes can cause the unit to run hot. Also excessive RPM in sump condition.	Drain oil and refill as specified for brakes. Switch to flow through cooling.
Brake will not release	A. Stuck valve or clogged	Brakes are designed to come on when system pressure drops below stated release pressure. If pressure cannot get to brake, the brake will not release.	Place pressure gauge in bleed port - check for adequate pressure. Replace defective line or component.
	B. Bad o-rings	If release piston will not hold pressure, brake will not release.	Replace o-rings.
	C. Discs frozen	These brakes are designed for only limited dynamic braking. A severe emergency stop or prolonged reduced release pressure operation may result in this type of damage.	Replace disc stack.