

Wheel Mount MULTIPLE DISC BRAKE

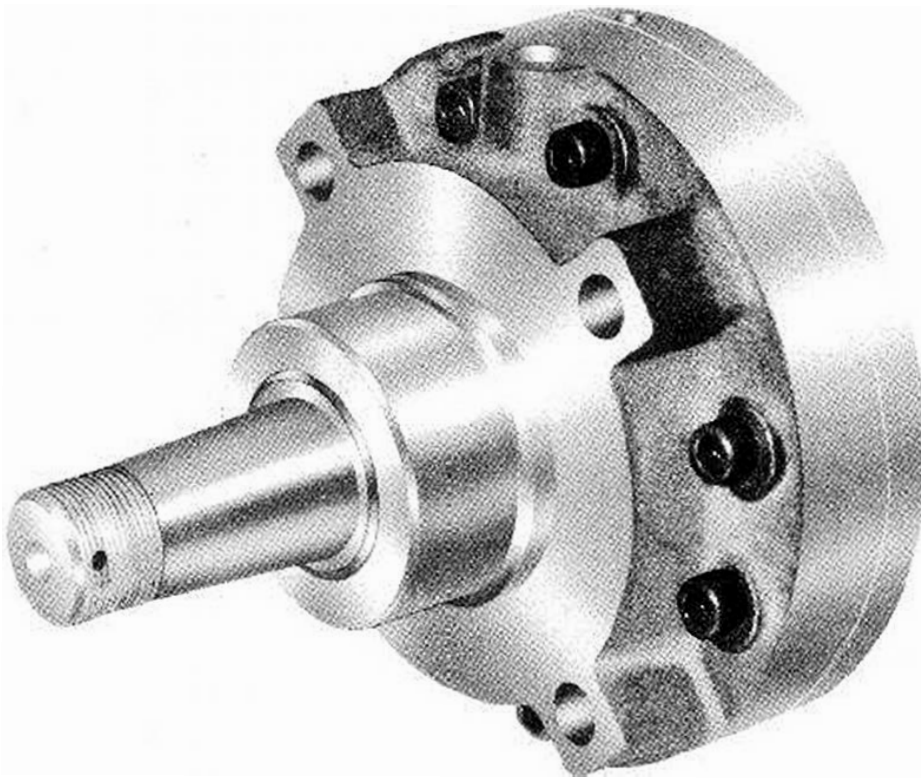

Service Instructions



This publication is not subject to any update service. Information contained in this publication was in effect at the time the publication was approved for printing and is subject to change without notice or liability. ZF Off-Highway Solutions Minnesota Inc. reserves the right to revise the information presented or to discontinue the production of parts described at any time.



TYPICAL BRAKE

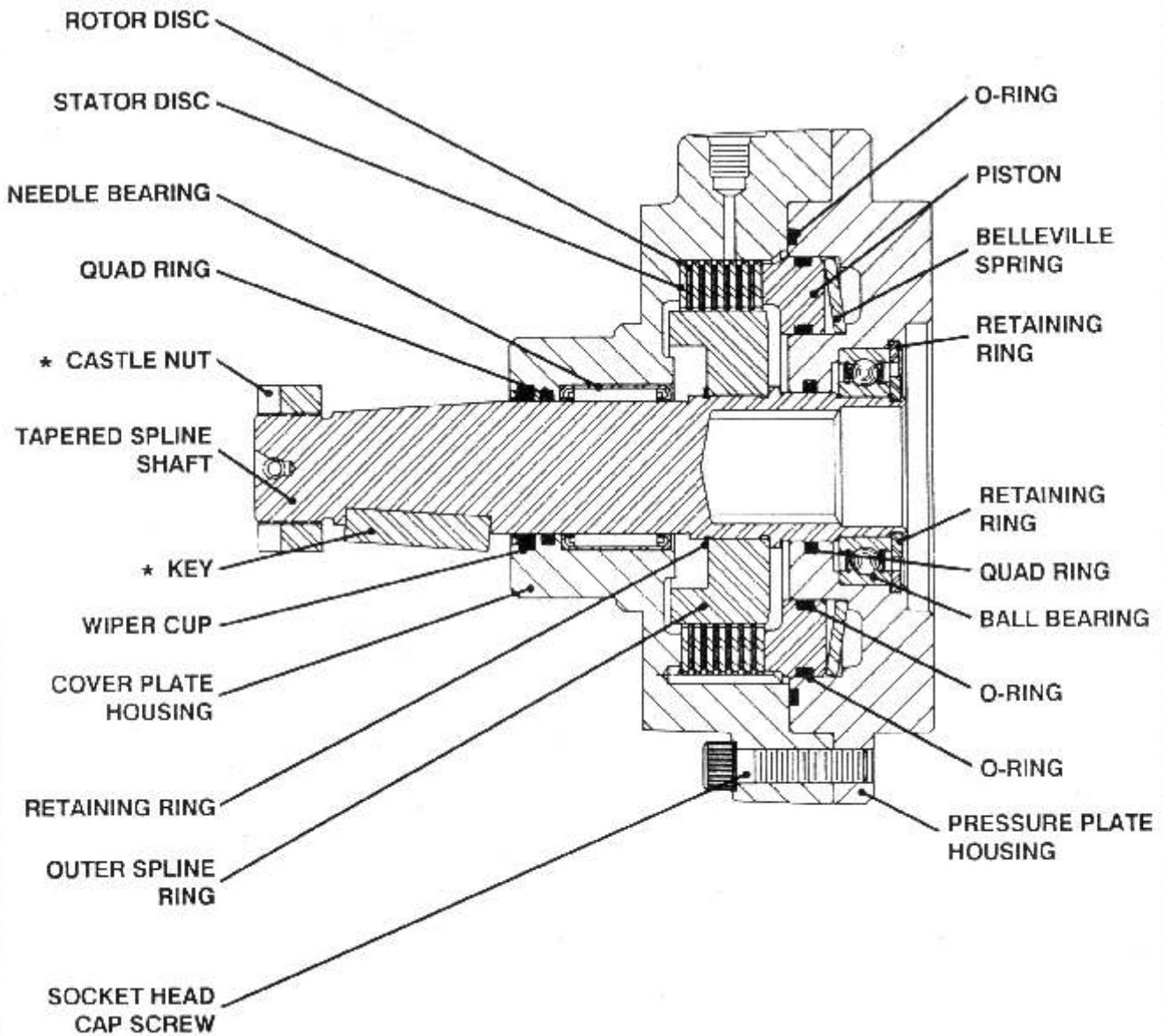

* Not used with all models

FIGURE 1

PRINCIPLES OF OPERATION

Wheel mount brakes are spring-set, hydraulically released, multi-disc brakes. They are used primarily for holding loads, vehicles, conveyors, etc. in place when the hydraulic drive system is shut down or fails. Although the brakes are rated at 500 psi maximum pressure they only require 310 psi to make them function normally.

It is very important to remember that any pressure on the brake's release piston will directly effect the level of torque.

Two application examples:

1. The brake has a release pressure of 200 psi. The actuation pres-

sure is provided by a charge pump. During certain phases of the machine's operation, the charge pump pressure dips from 200 psi to 100 psi. At 200 psi, the brake runs free (zero torque) but at 100 psi the brake will generate slightly less than half of its rated torque. The brake will drag - failure may occur. In this case, a brake should be selected which has a lower release pressure.

2. A brake has a release pressure of 200 psi. The system is set up to hold a load when a variable pump is shifted into neutral. Everything is running fine until

the filter clogs, causing a build-up of back pressure in the return line to the tank. At a pressure of 60 psi, the brake will lose 25% of its holding torque; thus the load may slip. The situation can be corrected by replacing the filter or adding an extra margin of safety to your required brake torque in the initial design.

These brakes are designed to give thousands of trouble-free hours of service when set up correctly in the hydraulic circuit.

DESCRIPTION OF MODEL NUMBERS

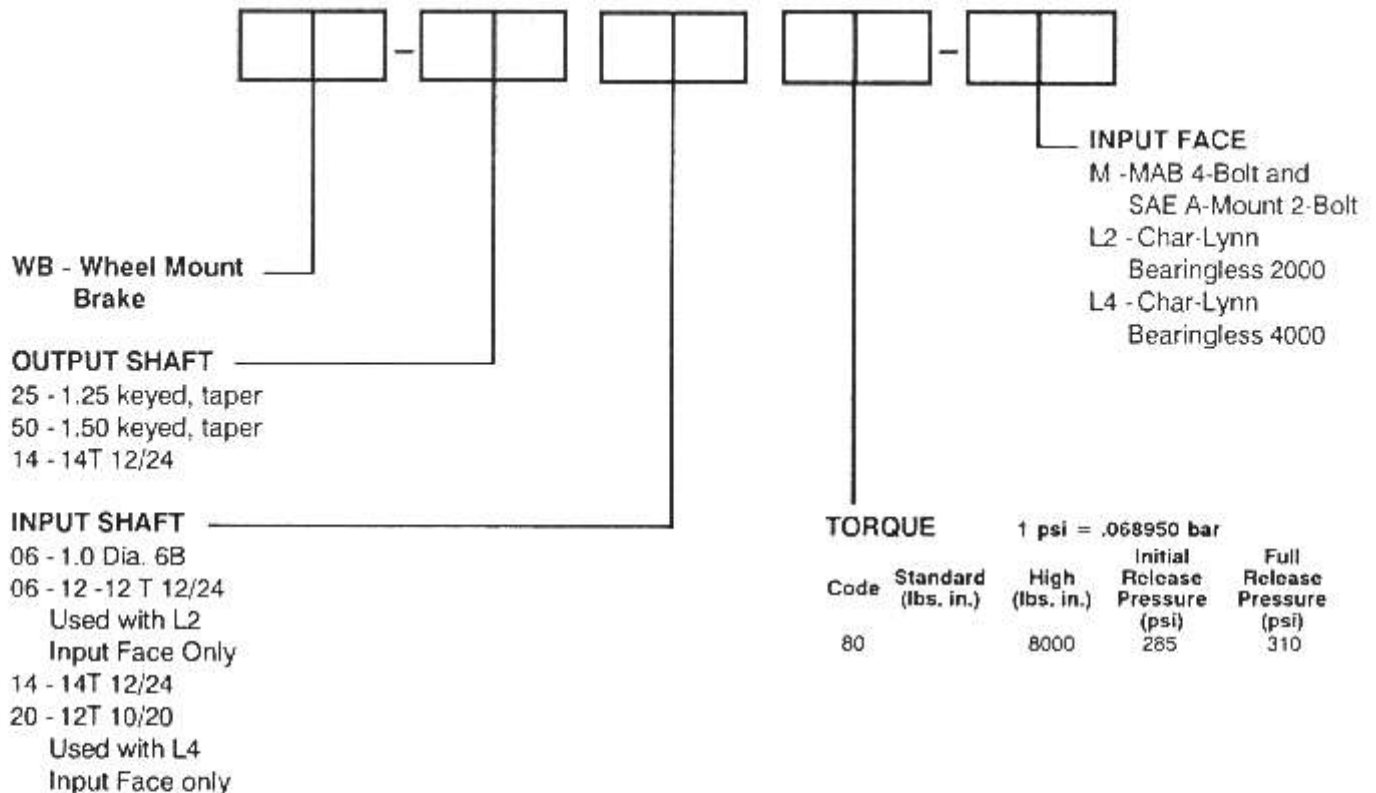

DISASSEMBLY

1. Remove castle nut (1) and key (7) from output end of spline shaft assembly (8).
2. Remove 8 socket head cap screws (2). A suitable holding fixture is useful to keep brake in position.
3. Remove cover (3) from brake assembly. Remove wiper cup (4) and quad ring seal (5) from cover (3). Bearing (6) is not field serviceable and may be damaged if removal is attempted.
4. Remove 7 stator discs (9) and 6 rotor discs (10).
5. Remove o-ring (19) from pressure plate (20).
6. Apply force to male end of spline shaft assembly (8) to allow removal of retaining ring (18) from opposite end of shaft.
7. Remove spline shaft assembly (8) from bearing (16) by tapping female end with soft mallet.
8. Remove piston (13) from pressure plate (20).
9. Remove o-rings (11 & 12) from piston (13).
10. Remove belleville spring (14) from pressure plate (20).
11. Remove quad ring seal (15) from pressure plate (20).
12. Remove retaining ring (17) from pressure plate (20) and press out bearing (16) if required.

ASSEMBLY

LUBRICATE ALL RUBBER COMPONENTS FROM REPAIR KIT WITH CLEAN TYPE FLUID USED IN THE SYSTEM.

1. Clean all parts thoroughly before assembling.
2. If removed, press bearing (16) into pressure plate (20) and install retaining ring (17).
3. Install quad ring seal (15) in pressure plate (20).
4. Install belleville spring (14) in pressure plate (20).
5. Install o-rings (11 & 12) on piston (13).
6. Insert piston (13) in bore of pressure plate (20).
7. Install spline shaft assembly (8) through pressure plate (20) and press into bearing (16). Install retaining ring (18) on end of spline shaft assembly (8).
8. Install o-ring (19) in pressure plate (20).
9. Install stator disc (9) on spline shaft assembly (8) and alternate with remaining rotor discs (10) and stator discs (9).
10. Install quad ring seal in cover (3).
11. Install wiper cup in cover (3).
12. Align external tabs on lining stack and install cover (3) until it bottoms on lining stack.
13. Rotate cover (3) if required to align screw holes with pressure plate (20).
14. Install 8 socket head cap screws (2) and tighten evenly to draw cover (3) to pressure plate (20). Torque socket head cap screws (2) to 35 ft. lbs. (See Note Below).
15. Install castle nut (1) and key (7) on output end of spline shaft assembly (8).

NOTE: Screws should have one or two drops of Loctite #242 applied to threads.

CAUTION

If hydrostatic bench testing is performed on the brake assembly, release pressure should not exceed 500 psi.

FOR REPAIR KIT INFORMATION REFER TO PAGE 7.

FIGURE 2

TYPICAL MODEL SHOWN

Note: Additional components are included in the repair kits to cover earlier design details. Please contact factory if additional assembly information is required on earlier design brakes.

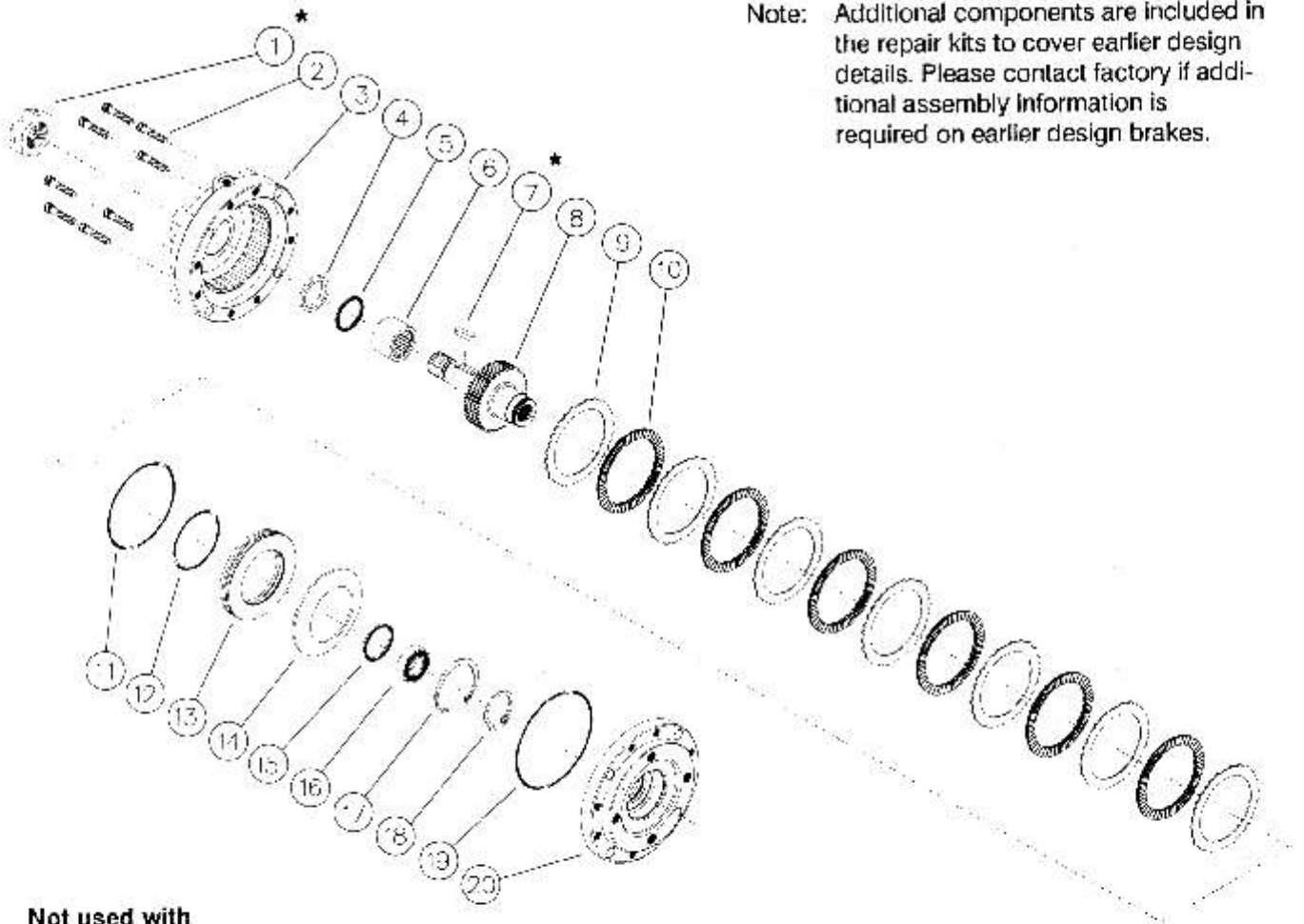

* Not used with all models

PARTS LIST

ITEM	DESCRIPTION	ITEM	DESCRIPTION
1	* CASTLE NUT	11	O-RING
2	CAP SCREW (8)	12	O-RING
3	COVER PLATE HOUSING	13	PISTON
4	WIPER CUP	14	BELLEVILLE SPRING
5	QUAD RING	15	QUAD RING
6	NEEDLE BEARING	16	BALL BEARING
7	* KEY	17	RETAINING RING
8	OUTER SPLINE RING & TAPERED SPLINE SHAFT	18	RETAINING RING
9	STATOR DISC	19	O-RING
10	ROTOR DISC	20	PRESSURE PLATE HOUSING

BLEEDING

1. Install brake in system and connect pressure lines.
2. Bleed pressure release section of brake by pressurizing side inlet port and allowing air to escape from top port. Pressure should not exceed 100 psi during bleeding.
3. Apply sufficient pressure to release brake and check for proper operation in system.

SERVICE DIAGNOSIS

PROBLEM	CAUSE	EXPLANATION	ACTION
Brake slips	A. Excessive pressure in hydraulic system	If there is back pressure in the actuation line of the brake, holding torque will be reduced.	Check filters, hose size, restrictions in other hydraulic components.
	B. Disc plates worn	The thickness of the disc stack sets the torque level. A thin stack reduces torque.	Check disc thickness
	C. Belleville spring broken or has taken a permanent set	Broken or set springs can cause reduced torque - a rare occurrence.	Check release pressure (See spring replacement)
Brake drags or runs hot	A. Low actuation pressure	The brake should be pressurized to minimum of 20 psi over the full release pressure under normal operating conditions. Lower pressures will cause the brake to drag thus generating heat.	Place pressure gauge in bleed port & check pressure with system on
	B. Bearing failure	If the bearing should fail, a large amount of drag can be generated.	Replace bearing
Brake will not release	A. Stuck or clogged valve	Brakes are designed to come on when system pressure drops below stated release pressure. If pressure cannot get to brake, the brake will not release. or component	Place pressure gauge in bleed port - check for adequate pressure - Replace defective line
	B. Bad o-rings	If release piston will not hold pressure, brake will not release.	Replace o-rings
	C. Discs frozen	These brakes are designed for only limited dynamic braking. A severe emergency stop or prolonged reduced release pressure operation may result in this type of damage.	Replace disc stack

REPAIR KITS

(Refer to Page 5 for item numbers)

NUMBER	DESCRIPTION	INCLUDES
12-501-196	O-ring Kit	Wiper Cup (4) Quad Rings (5 & 15) O-rings (11 & 12) O-ring (19) Loctite
12-501-200	Lining Kit	Wiper Cup (4) Quad Rings (5 & 15) Stator Discs (9) Rotor Discs (10) Loctite
12-501-198	Bearing Kit	Wiper Cup (4) Quad Rings (5 & 15) Bearing (16) O-ring (19) Loctite
12-501-202	Spring Kit	Wiper Cup (4) Quad Rings (5 & 15) Spring (14) Loctite

NOTE: All repair kits include mounting face gaskets and o-rings. Some motors and gearboxes allow for the use of o-rings to seal the mounting faces on either side of the brake. Do not use the o-ring and face gasket together to seal a mounting face.