

SPRING APPLY HYDRAULIC RELEASE Caliper Disc Brake



Installation and Service Instructions

TABLE 1

Model Number	Seal Kit Number	Repair Kit Number	Lining Kit Number
02-530-132 (HO)	02-500-136	*02-500-180	20-060-054

HO = Mineral Base Hydraulic Oil

* Belleville springs are pre-greased. DO NOT remove grease from springs. (See grease notes in FIGURE 4).

NOTE: If your product number is not listed, contact ZF Off-Highway Solutions Minnesota Inc. for information.

BE SURE TO READ GENERAL INSTALLATION GUIDELINES SHEET (81-600-001) BEFORE PROCEEDING

⚠ WARNING

ZF Off-Highway Solutions Minnesota Inc. disc brake linings do not contain asbestos. Brake lining compounds do, however, contain elements that may become airborne during the life of the lining. To prevent any health problems associated with lining dust, we suggest ventilators be installed as needed on enclosed or stationary equipment. A Safety Data Sheet is available upon request.

When installing this Spring Brake, it is of utmost importance that the caliper be centered evenly and squarely over the disc. This will ensure even lining to disc contact. When linings have been worn to a point of replacement, replace with a new lining kit. This Spring Brake is designed to be used with a disc thickness of 12.7 mm (0.50 in).

⚠ CAUTION

Minimum recommended disc thickness for this brake is 11.1 mm (0.438 in). For other disc thicknesses, contact ZF Off-Highway Solutions Minnesota Inc.

MOUNTING PROCEDURE

1. The mounting surface to disc face dimension should be closely held as this provides for the required caliper movement. Use shims as needed to obtain the proper distance, Figure 2.
2. Using Table 2, determine "A" dimension and locate mounting bracket assembly holes.
3. Install lock nut and adjusting screw into piston. Push lining assembly into brake housing.
4. Mount brake and bracket assembly on disc and bolt securely to machine using SAE Grade 8 or better mounting bolts with lock washers, Figure 2.

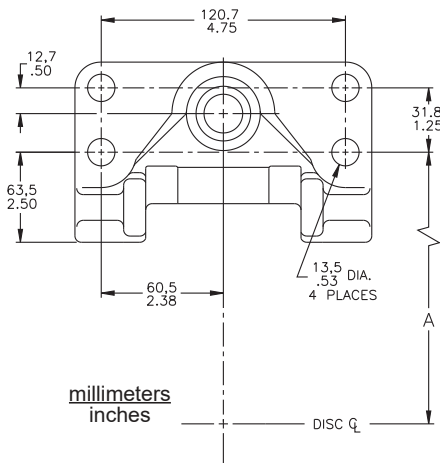

FIGURE 1

DISC CENTERLINE TO MOUNTING HOLE DIMENSION

Disc Diameter	"A" Dimension
229 mm (9 in)	156 mm (6.125 in)
254 mm (10 in)	168 mm (6.625 in)
305 mm (12 in)	194 mm (7.625 in)
356 mm (14 in)	219 mm (8.625 in)
406 mm (16 in)	248 mm (9.75 in)
457 mm (18 in)	273 mm (10.75 in)
508 mm (20 in)	298 mm (11.75 in)
559 mm (22 in)	324 mm (12.75 in)
610 mm (24 in)	349 mm (13.75 in)

TABLE 2

NOTE: For disc diameters greater than 24 inches, add 1.75 inches to disc radius to obtain "A" dimension.

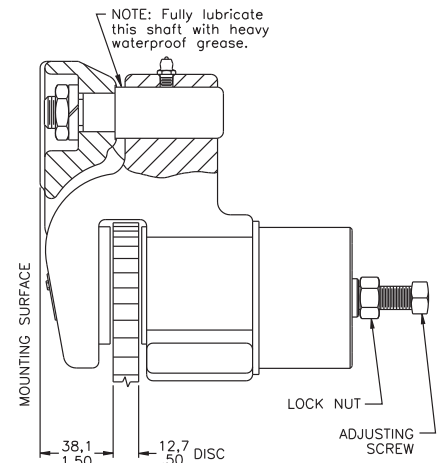

FIGURE 2

PLUMBING PROCEDURE

1. After caliper assembly is mounted on machine, install hydraulic line and bleeder screw (provided with brake). **NOTE: All porting is designed for #4 SAE o-ring boss port adapter.**
2. Bleed system making sure all air is eliminated. Apply rated hydraulic pressure and check for leaks.
3. Torque bleeder screw 12.2-20.3 N·m (9-15 lb-ft).

CHANGE LINING PROCEDURE

(Refer to Figure 3)

NOTE

New linings must be kept free of oil, grease, etc.

1. Loosen lock nut and back off adjusting screw.
2. Disconnect fluid line from brake.

CAUTION

Cap end of fluid line to prevent entry of dirt into hydraulic system.

3. Remove bolts used to fasten the mounting bracket assembly to machine. Remove brake and mounting bracket assembly from machine and remove mounting bracket assembly from brake.
4. Place brake in a soft jawed vise with disc clearance slot facing up. **NOTE: Clamping should be done on the sides of the brake on machined surfaces.**
5. Remove screws and bushings. Using a thin blade tool, pry lining from housing and remove through disc clearance slot.

6. Force lining assembly from housing by advancing adjusting screw. Remove lining assembly through disc clearance slot.
7. Lubricate new lining assembly seal with clean type fluid used in the system and install the new lining assembly into housing through disc clearance slot. Back off adjusting screw to allow room for the new lining assembly.
8. Insert new bushings into new lining. Install new lining into housing through disc clearance slot. Line up holes with the housing and fasten with new screws and torque 2.8-4.0 N·m (25-35 lb-in).
9. Reinstall brake on machine as described in MOUNTING PROCEDURE Section (step 4) and PLUMBING PROCEDURE Section.
10. Adjust brake as described in BRAKE ADJUSTMENT PROCEDURE Section.

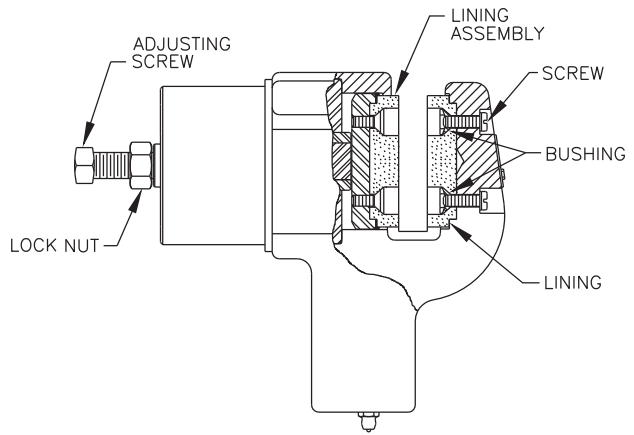
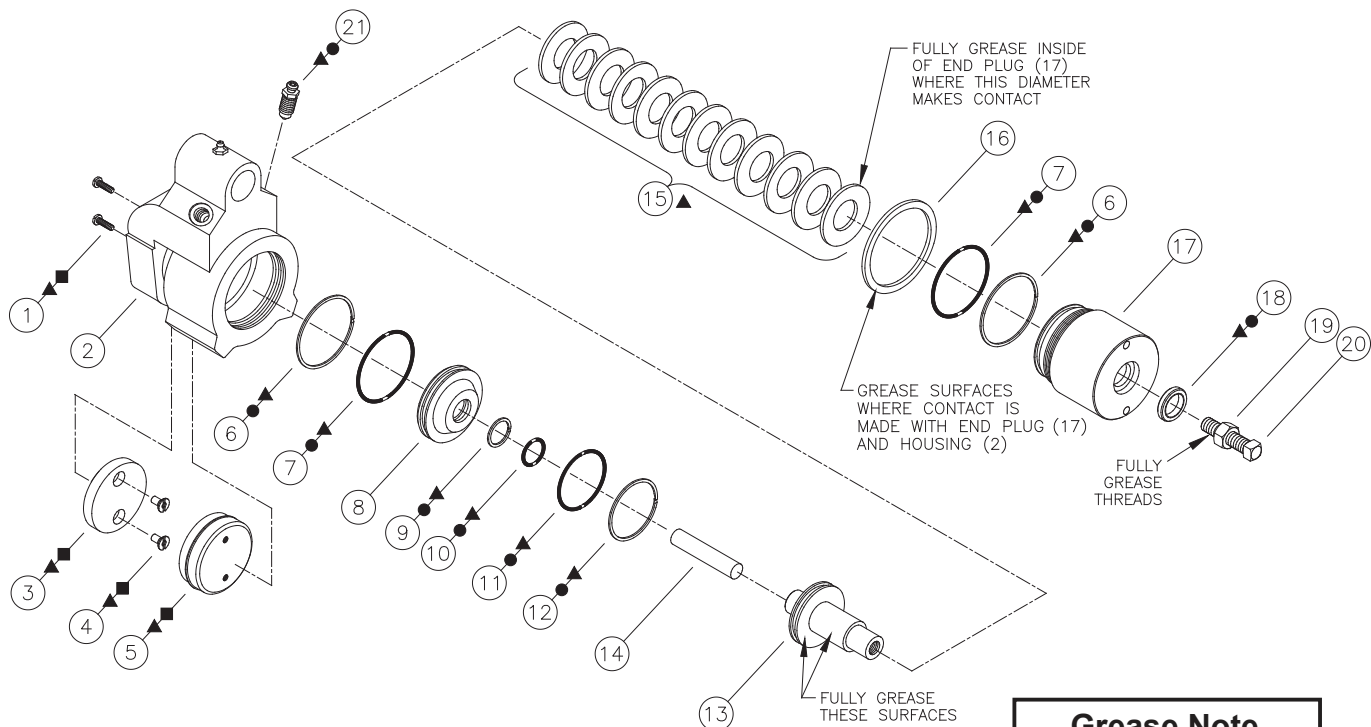

FIGURE 3



- Included in Seal Kit 02-500-136
- ▲ Included in Repair Kit 02-500-180
- Included in Lining Kit 20-060-054

FIGURE 4

Grease Note
Hydraulic Oil Models must use a mineral base grease.

BRAKE ADJUSTMENT PROCEDURE

1. Apply rated hydraulic pressure.
2. Loosen lock nut and adjusting screw.
3. Place 0.30 mm (0.012 in) thick shim between disc and one of the linings.
4. Tighten adjusting screw until it is just possible to remove the shim.
5. Torque lock nut 29.8-36.6 N·m (22-27 lb·ft) while holding adjusting screw with a wrench. Remove shim and release hydraulic pressure.

CHANGE SEAL KIT OR REPAIR KIT PROCEDURE

(Refer to Figure 4)

If repair kit is being installed see CHANGE LINING PROCEDURE Section

NOTE

When removing seals and back-up rings be careful not to scratch or mar pistons.

1. Loosen lock nut (19) and remove adjusting screw (20) from piston (13).
2. Disconnect fluid line from brake.

CAUTION

Cap end of fluid line to prevent entry of dirt into hydraulic system.

3. Remove bolts used to fasten the mounting bracket assembly to machine. Remove brake and mounting bracket assembly from machine and remove mounting bracket assembly from brake. Drain fluid from brake.
4. Place brake in a soft jawed vise with end plug (17) in a vertical position. **NOTE: Clamping should be done on the sides of the brake on machined surfaces.**
5. Remove end plug (17) and spacer (16) using a spanner wrench. Using a thin blade tool, remove seal (18), o-ring (7), and back-up ring (6) from end plug (17).
6. Remove belleville springs (15). Note the stacking sequence of the belleville springs (15).
7. Remove piston (13) from housing (2) bore. Remove push rod (14), o-ring (11), and back-up ring (12) from piston (13).

8. Remove piston (8) from housing (2) bore. Remove back-up ring (6) and o-ring (7) from piston (8).
9. Remove bleeder screw (21).
10. Lubricate all rubber components from the seal kit or repair kit with clean type fluid used in the system.
11. Wash all parts and housing bore thoroughly with clean type fluid used in the system and keep free of all contaminants, dirt, and debris. **NOTE: Use a heavy, water proof grease to lubricate surfaces as shown in Figure 4. See Grease Note.**
12. Install new bleeder screw (21) and finger tighten. Note that bleeder screw is properly torqued in the PLUMBING PROCEDURES after air has been bled from the system.
13. Install new o-rings (7 & 10) and new back-up rings (6 & 9) on piston (8). Note order of components. **NOTE: When installing back-up rings it is essential that surfaces of diagonal splice match with each other after back-up ring is installed in groove.**
14. Install piston (8) into housing (2) bore. Note direction of piston (8). **NOTE: When installing piston (8), be careful not to pinch o-ring on inlet ports.**
15. Install new back-up ring (12) and new o-ring (11) on piston (13). Note order of components. Make sure push rod (14) is in bore of piston (13). Install piston (13) into housing (2) bore.
16. Fully lubricate threads of adjusting screw (20) and lock nut (19) and install into piston (13).
17. Install belleville springs (15) over end of piston (13). Follow the stacking sequence shown in Figure 4. **NOTE: If seal kit is being installed, use existing belleville springs and completely lubricate with a light coat of heavy, water proof grease (See Grease Note, Figure 4). If repair kit is being installed use new belleville springs, already greased. Note that the belleville spring nearest the end plug must contact the end plug on its outside diameter.**
18. Install new back-up ring (6) and new o-ring (7) on end plug (17).
19. Install spacer (16) and end plug (17). Torque end plug (17) to approximately 20.3 N·m (15 lb·ft).
20. To continue assembly refer to MOUNTING PROCEDURE Section (steps 3 & 4), PLUMBING PROCEDURE Section, and BRAKE ADJUSTMENT PROCEDURE Section.

This publication is not subject to any update service. Information contained in this publication was in effect at the time the publication was approved for printing and is subject to change without notice or liability. ZF Off-Highway Solutions Minnesota Inc. reserves the right to revise the information presented or to discontinue the production of parts described at any time.

