

SPRING APPLY Caliper Disc Brake



Installation and Service Instructions

TABLE 1

Caliper Model Number	Caliper with Rectangular Bracket Model Number	Caliper with Triangular Bracket Model Number	Lining/Seal Kit Number	Seal Kit Number	* Repair Kit Number
01-530-416 (HO)	02-530-414 (HO)	03-530-416 (HO)	20-060-094	02-500-058	02-500-172
01-530-616 (HO)	02-530-616 (HO)	03-530-616 (HO)	20-060-094	02-500-058	02-500-176
		03-530-618 (HO)	20-060-101	02-500-058	02-500-213

HO = Mineral Base Hydraulic Oil

* Belleville springs are pre-greased. DO NOT remove grease from springs. See GREASE NOTE on page 2, Figure 5.

NOTE: If your product number is not listed, contact ZF Off-Highway Solutions Minnesota Inc. for information.

BE SURE TO READ GENERAL INSTALLATION GUIDELINES SHEET (81-600-001) BEFORE PROCEEDING

⚠ WARNING

ZF Off-Highway Solutions Minnesota Inc. disc brake linings do not contain asbestos. Brake lining compounds do, however, contain elements that may become airborne during the life of the lining. To prevent any health problems associated with lining dust, we suggest ventilators be installed as needed on enclosed or stationary equipment. A Safety Data Sheet is available upon request.

When installing these Spring Apply Brakes, it is of utmost importance that the caliper be centered evenly and squarely over the disc. This will ensure even lining to disc contact. When linings have been worn to a point of replacement, replace with the lining kit specified in TABLE 1. This series of 530 Spring Apply Brakes is designed for use with a disc thickness of 7.9-9.7 mm (0.31-0.38 in).

MOUNTING PROCEDURE

- Figures 1 and 2 illustrate the two methods of mounting this series of brakes. See GREASE NOTE, Figure 5 on page 2. The mounting surface to disc face dimension should be closely held as this provides for the required caliper movement. Use shims as needed to obtain the proper distance.
- Using TABLE 2 and Figures 3 and 4 on page 2 determine "A" dimension and locate mounting bracket assembly holes.

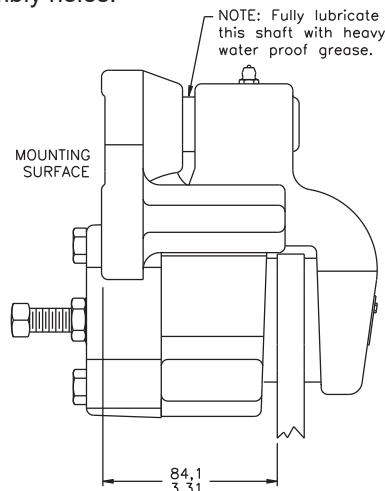

FIGURE 1

- Loosen lock nut and back off adjusting screw slightly. Push lining assembly back into the brake housing.
- Mount brake and bracket assembly on disc and bolt securely to the machine using SAE grade 8 or better mounting bolts with lock washers.

NOTE

Dimensions shown in Figures 1 and 2 are typical for all models. Mounting surface to disc face dimension is typical of rectangular and triangular brackets. Mounting bolts not included.

PLUMBING PROCEDURE

- After brake is mounted on machine, install bleeder screw (provided with brake) and hydraulic line. **NOTE: All porting is designed for #4 SAE o-ring boss port adapters.**
- Bleed system making sure all air is eliminated. Apply rated pressure and check for leaks.
- Torque bleeder screw 12.2-20.3 N·m (9-15 lb·ft).

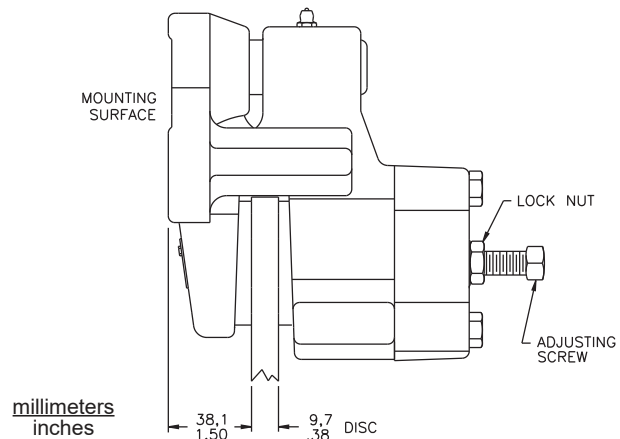

FIGURE 2

DISC CENTERLINE TO MOUNTING HOLE DIMENSION

Disc Diameter	Rectangular Mount "A" Dimension	Triangular Mount "A" Dimension
228.6 mm (9 in)	155.6 mm (6.125 in)	117.5 mm (4.625 in)
254.0 mm (10 in)	168.3 mm (6.625 in)	130.2 mm (5.125 in)
304.8 mm (12 in)	193.7 mm (7.625 in)	155.6 mm (6.125 in)
356.6 mm (14 in)	219.1 mm (8.625 in)	181.0 mm (7.125 in)
406.4 mm (16 in)	247.6 mm (9.75 in)	206.4 mm (8.125 in)
457.2 mm (18 in)	273.0 mm (10.75 in)	231.8 mm (9.125 in)
508.0 mm (20 in)	298.4 mm (11.75 in)	257.2 mm (10.125 in)
558.8 mm (22 in)	323.8 mm (12.75 in)	282.6 mm (11.125 in)
609.6 mm (24 in)	349.2 mm (13.75 in)	308.0 mm (12.125 in)

TABLE 2

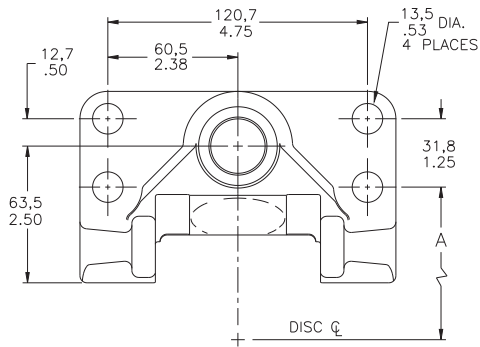

FIGURE 3
(rectangular mount)

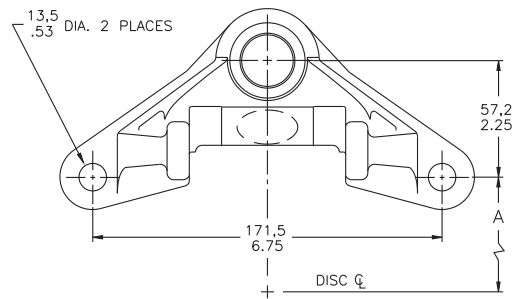
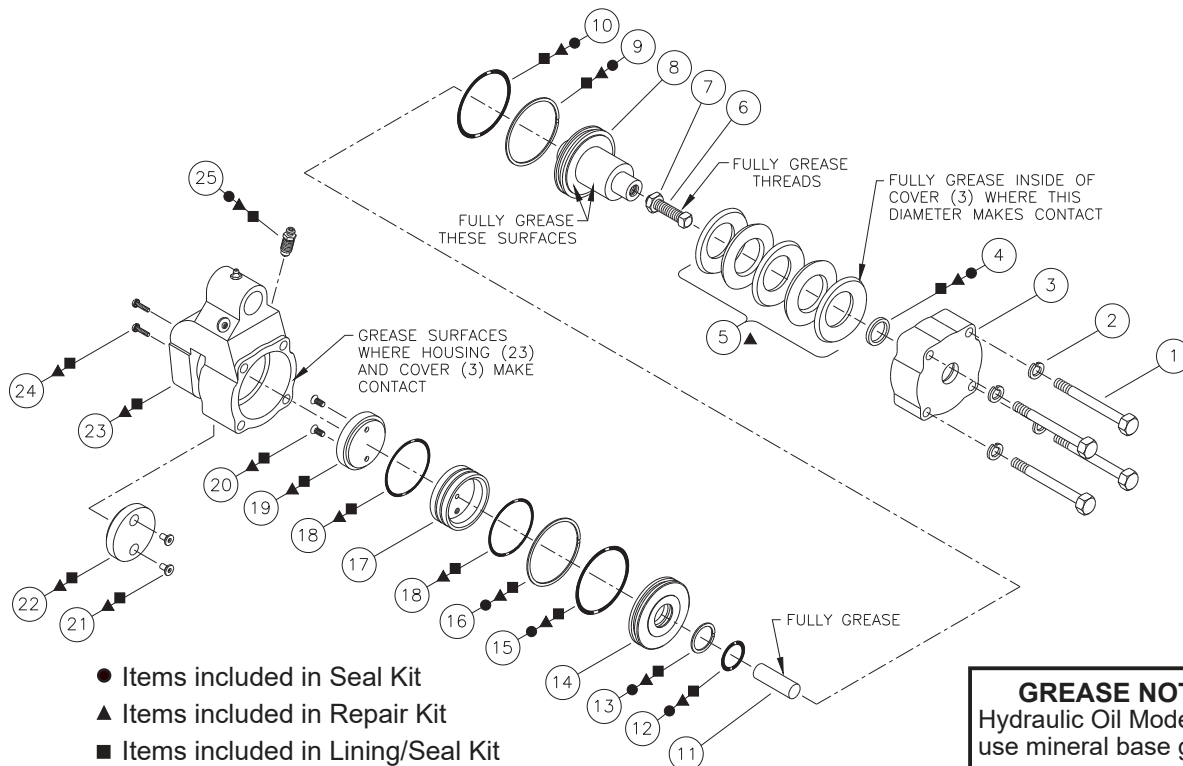

FIGURE 4
(triangular mount)

NOTE: For disc diameters greater than 609.6 mm (24 inch) add 44.4 mm (1.75 in) to disc radius to obtain "A" dimension.

NOTE: For disc diameters greater than 609.6 mm (24 inch) add 3.2 mm (0.125 in) to disc radius to obtain "A" dimension.



- Items included in Seal Kit
- ▲ Items included in Repair Kit
- Items included in Lining/Seal Kit

GREASE NOTE
Hydraulic Oil Models must use mineral base grease.

FIGURE 5

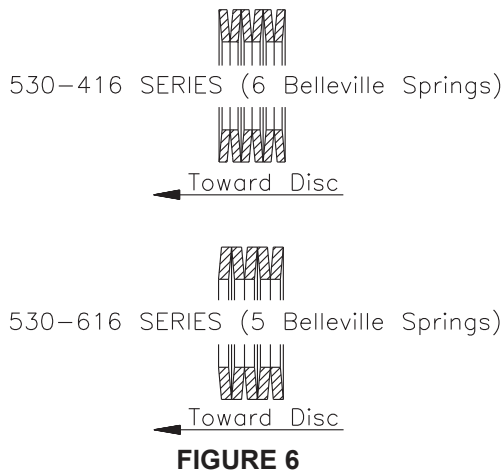

FIGURE 6

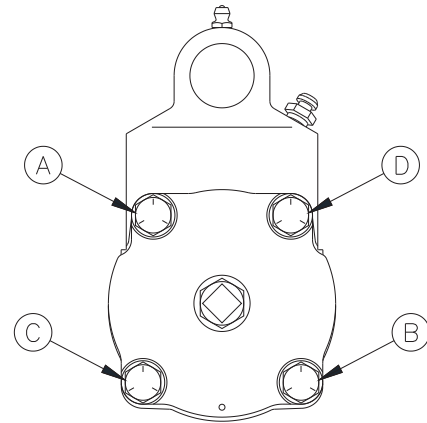

FIGURE 7

CHANGE SEAL KIT, REPAIR KIT, OR LINING KIT PROCEDURE

(Refer to Figure 5)

If Seal Kit is being installed, see steps 1 through 10, 13, 14, and 18 through 26.

NOTE

When removing seals and back-up rings be careful not to scratch or mar pistons. When installing new seals in the brake, make sure the kit being used is the proper one for the system fluid.

New linings must be kept free of oil, grease, etc.

1. Loosen lock nut (7) and back off adjusting screw (6).
2. Disconnect fluid line from the brake.

⚠ CAUTION

Cap end of fluid line to prevent entry of dirt into the hydraulic system.

3. Remove bolts used to fasten the mounting bracket assembly to machine. Remove brake and mounting bracket assembly from machine and remove mounting bracket assembly from brake.
4. Place the brake in a soft jawed vise with cover (3) in a vertical position. **NOTE: Clamping should be done on the sides of the brake on the machined surfaces.**
5. Remove bleeder screw (25).

⚠ CAUTION

Loosen cap screws evenly and in order A, B, C, D until spring preload is released. See Figure 7.

6. To remove cover (3), loosen four cap screws (1).
7. Remove cap screws (1), lock washers (2), and cover (3). Using a thin blade tool, remove seal (4) from cover (3).
8. Remove belleville springs (5). Note the stacking sequence of belleville springs.
9. Remove piston (8) from housing (23) bore. Remove o-ring (10) and back-up ring (9) from piston. Push rod (11) should also come out with piston.
10. Remove piston (14) from housing (23) bore. Remove o-rings (12 & 15) and back-up rings (13 & 16) from piston.
11. Remove piston (17) and lining (19) assembly from housing (23) bore. Holding assembly on a flat surface, separate lining (19) and piston (17) by removing flat head screws (20). Remove o-rings (18) from piston (17).

12. Loosen vise jaws and rotate brake so the disc clearance slot is facing upward. Remove pan head screws (24), lining (22), and bushings (21) from housing (23).
13. Lubricate all rubber components from kit with clean type fluid used in the system.
14. Wash all parts and housing bore thoroughly with clean type fluid used in the system and keep free of all contaminants, dirt, and debris. **NOTE: Use a heavy, waterproof grease to lubricate surfaces as shown in Figure 5 on page 2. See GREASE NOTE.**
15. Install new lining (22) in housing (23) using new bushings (21) and new pan head screws (24). Torque screws (24) 2.8-4.0 N·m (25-35 lb·in).
16. Rotate the brake to original position in vise.
17. Install new lining (19) on piston (17) using new flat head screws (20) and torque 2.7-3.4 N·m (24-30 lb·in). Install new o-rings (18) on piston (17) and insert assembly into housing (23) bore.
18. Install new bleeder screw (25) and finger tighten.
19. Install new o-rings (12 & 15) and new back-up rings (13 & 16) on piston (14). Note order of components. **NOTE: When installing back-up rings it is essential that the surfaces of the diagonal splice match with each other after o-ring is installed in groove.**
20. Install piston (14) into housing (23) bore. Note direction of piston. **NOTE: When inserting piston, be sure not to pinch the o-ring on inlet ports.**
21. Install new back-up ring (9) and new o-ring (10) on piston (8). Note order of components. Make sure push rod (11) is in the bore of piston (8). Then install piston into housing (23) bore.
22. Fully lubricate threads of adjusting screw (6) and lock nut (7) and install into piston (8).
23. Install belleville springs (5) over end of piston (8). Follow the stacking sequence shown in Figure 6 on page 3. **NOTE: If Lining Kit or Seal Kit is being installed use existing belleville springs after completely lubricating them with a light coat of heavy, waterproof grease. See GREASE NOTE in Figure 5 on page 2. If Repair Kit is being installed use new belleville springs, already greased. Note that the belleville spring nearest the cover must contact the cover on its outside diameter.**

continued...

24. Install new seal (4) in cover (3).
25. Install cover (3), lock washers (2) and cap screws (1).
Torque cap screws 29.8-36.6 N·m (22-27 lb·ft).

▲ CAUTION

Tighten cap screws evenly and in order A, B, C, D.
See Figure 7 on page 3.

26. Loosen lock nut (7) and back off adjusting screw (6) slightly. Push lining assembly back into the brake housing (23). Mount brake and bracket assembly on machine disc and bolt securely to the machine using SAE grade 8 or better mounting bolts and lock washers.
27. Reattach the hydraulic line. Bleed system making sure all air is eliminated. Apply rated pressure and check for leaks. Torque bleeder screw (25) 12.2-20.3 N·m (9-15 lb·ft).
28. Refer to BRAKE ADJUSTMENT PROCEDURE.

BRAKE ADJUSTMENT PROCEDURE

(Refer to Figure 2)

1. Apply rated hydraulic pressure.
2. Loosen lock nut and adjusting screw.
3. Place a 0.30 mm (0.012 in) thick shim between disc and one of the linings.
4. Tighten adjusting screw until it is just possible to remove the shim.
5. Torque lock nut 29.8-36.6 N·m (22-27 lb·ft) while holding adjusting screw with a wrench. Remove shim and release hydraulic pressure.

This publication is not subject to any update service. Information contained in this publication was in effect at the time the publication was approved for printing and is subject to change without notice or liability. ZF Off-Highway Solutions Minnesota Inc. reserves the right to revise the information presented or to discontinue the production of parts described at any time.

