

HYDRAULIC APPLY Caliper Disc Brake



Installation and Service Instructions

TABLE 1

Model Number	Lining Kit Number	Repair Kit Number	Model Number	Lining Kit Number	Repair Kit Number
02-515-025 (BF)	20-060-082	02-500-039	02-515-042 (HO)	20-060-082	02-500-038
02-515-030 (HO)	20-060-082	02-500-038	02-515-059 (BF)	20-060-126	02-500-039
02-515-036 (HO)	20-060-063	02-500-038	02-515-188 (HO)	20-060-117	02-500-038
02-515-041 (BF)	20-060-082	02-500-039			

BF = Brake Fluid HO = Mineral Base Hydraulic Oil

NOTE: If your product number is not listed, contact ZF Off-Highway Solutions Minnesota Inc. for information.

READ GENERAL INSTALLATION GUIDELINES SHEET (81-600-001) BEFORE PROCEEDING

⚠ WARNING

ZF Off-Highway Solutions Minnesota Inc. disc brake linings do not contain asbestos. Brake lining compounds do, however, contain elements that may become airborne during the life of the lining. To prevent any health problems associated with lining dust, we suggest ventilators be installed as needed on enclosed or stationary equipment. A Safety Data Sheet is available upon request.

When installing these 515 Series Brakes, it is of utmost importance to maintain parallelism between mounting bolts and that caliper be centered evenly and squarely over disc. This will prevent binding of caliper and ensure even lining to disc contact.

MOUNTING PROCEDURE

1. Using Figure 1 and Table 2, determine "A" dimension and locate caliper mounting holes.
2. Mount brake on disc and bolt securely to vehicle or machine using SAE grade 5 or better mounting bolts or pins.

⚠ CAUTION

Models 02-515-041 and 02-515-042 are designed to used with a disc thickness of 6.4-9.5 mm (0.250-0.375 in). All other models listed in TABLE 1 are designed to be used with a disc thickness of 12.7 mm (0.50 in). For other disc thicknesses, contact ZF Off-Highway Solutions Minnesota Inc.

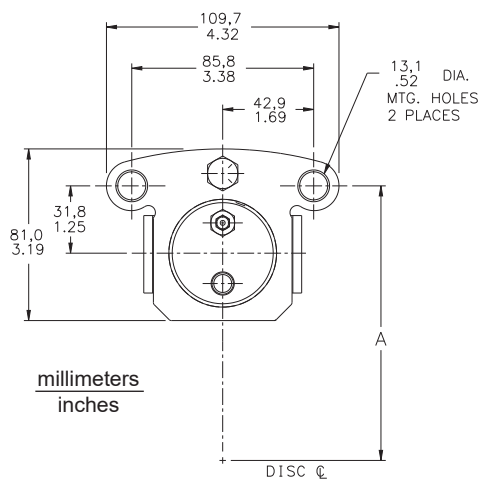

FIGURE 1

DISC CENTERLINE TO MOUNTING HOLE DIMENSION

Disc Diameter	"A" Dimension
152.4 mm (6 in)	85.9 mm (3.38 in)
203.2 mm (8 in)	111.3 mm (4.38 in)
254.0 mm (10 in)	136.7 mm (5.38 in)
304.8 mm (12 in)	162.1 mm (6.38 in)
355.6 mm (14 in)	187.5 mm (7.38 in)
406.4 mm (16 in)	212.9 mm (8.38 in)
457.2 mm (18 in)	238.3 mm (9.38 in)
508.0 mm (20 in)	263.7 mm (10.38 in)

TABLE 2

For disc diameters greater than 508.0 mm, add 9.7 mm (20 in, add 0.38 in) to disc radius to obtain "A" dimension.

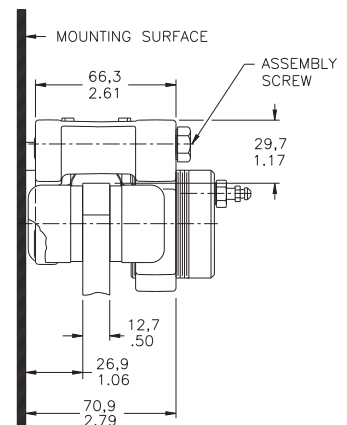

FIGURE 2

HYDRAULIC CONNECTION AND ADJUSTMENT PROCEDURE

(Refer to Figure 3)

Port Size: 1/8-27 NPTF

1. Thread in brake module housing (2) until a total clearance of approximately 0.030 mm (0.012 in) is obtained between disc and linings. **NOTE: Make sure piston (5) is bottomed out in brake module housing (2).**
2. Back off brake module housing (2) as required to position ports in vertical alignment.
3. Tighten set screw (8).
4. Move bleeder screw (1) to higher of two ports for ease of bleeding. Torque bleeder screw (1) 16.3-19.0 N·m (12-14 lb·ft)
5. Install hydraulic line in lower port.
6. Bleed system making sure all air is eliminated.

⚠ CAUTION

During the bleeding process for these 515 Series Brakes, hydraulic pressure should not exceed 13.8 bar (200 PSI).

7. Apply rated hydraulic pressure and check for leaks.

CHANGE SEAL PROCEDURE

(Refer to Figures 3 and 4)

See Table 1 for Repair Kit required for your brake.

1. Disconnect necessary fluid line from brake and remove brake and remove caliper from vehicle or machine.

⚠ CAUTION

Cap the end of fluid line to prevent entry of dirt into the hydraulic system.

2. Remove set screw (8) from housing (11) and remove brake module housing (2) from housing (11).
3. Place brake module housing (2) face down on bench, support brake module so piston (5) can be eased out of bore. **This is accomplished by carefully introducing low air pressure, 0.7-1.0 bar (10-15 PSI), through the hydraulic line port.**

⚠ CAUTION

Do not use high pressure as it is dangerous and unnecessary. Use just enough air pressure to ease the piston out of the bore. Do not blow piston out of the bore. If the piston is seized or cocked, or does not come out readily, release the air pressure and use a soft (brass) hammer to rap sharply on and around the end of the piston. Reapply air pressure to remove the piston.

4. Remove o-ring (3) and back-up ring (4) from piston (5). **NOTE: Be careful not to scratch or mar piston.**
5. Clean all parts thoroughly and lubricate all rubber components from repair kit with clean type fluid used in the system.

6. Carefully install new o-ring (3) and new back-up ring (4) on piston (5). Note order of back-up ring and o-ring
7. Lubricate piston (5) with clean type system fluid and install in brake module housing (2). Note the direction of piston and be sure it is bottomed out in brake module.
8. Thread brake module housing (2) into housing (11) until a total clearance of approximately 0.30 mm (0.012 in) is obtained between disc and linings.
9. Back of brake module housing (2) as required to position ports in vertical alignment.
10. Insert new nylon plug (7) into set screw (8) hole. Install nylon plug (7) even if originally not included in your model.
11. Install and tighten set screw (8).
12. Move bleeder screw (1) to higher of two ports for ease of bleeding. Torque bleeder screw (1) 16.3-19.0 N·m (12-14 lb·ft).
13. Install hydraulic line in lower port.
14. Bleed system making sure all air is eliminated. Apply hydraulic pressure and check for leaks.

CHANGE LINING PROCEDURE

(Refer to Figure 3)

See Table 1 for Lining Kit required for your brake.

Lining assemblies (10) can be replaced without removing brake module housing (2).

1. Remove cap screw (6) and spring clip (9) and allow lining assemblies (10) to drop out of housing (11). **NOTE: On small diameter discs with large hubs, it may be necessary to remove one mounting bolt and swing housing aside to free lining assemblies. Earlier models used a compression spring which is not included in the lining kit.**
2. Make sure piston (5) is bottomed out in brake module housing (2). Loosen set screw (8) and thread brake module housing (2) out of housing (11) so piston (5) is flush with housing (11).
3. Install new lining assemblies (10) in housing (11).
4. Install new spring clip (9) and cap screw (6) and torque 13.6-16.3 N·m (10-12 lb·ft). **NOTE: If the lining kit does not include new spring clip (9) reinstall compression spring.**
5. To continue refer to HYDRAULIC CONNECTION and ADJUSTMENT PROCEDURE Section.

- Items included in Repair Kit
- ▲ Items included in Lining Kit
- * Not included in all Lining Kits

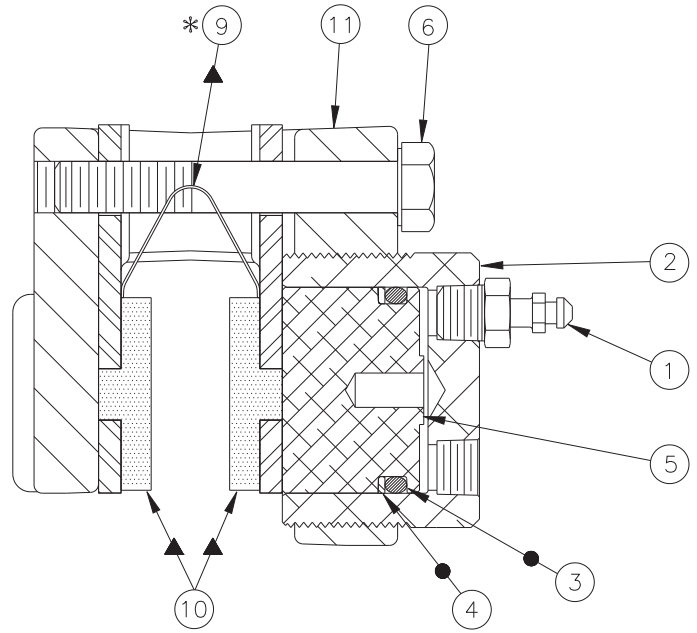

FIGURE 3

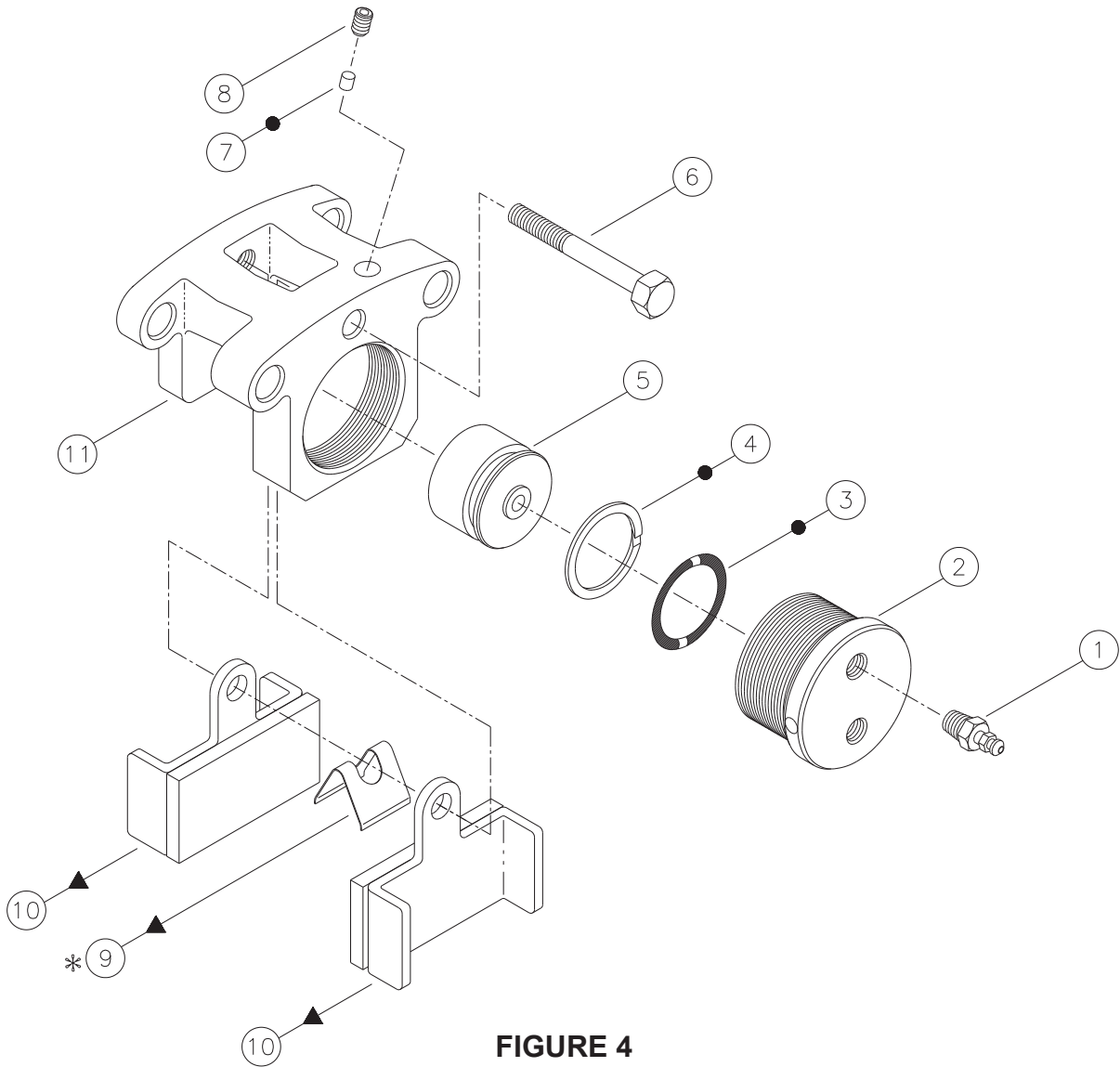

FIGURE 4

This publication is not subject to any update service. Information contained in this publication was in effect at the time the publication was approved for printing and is subject to change without notice or liability. ZF Off-Highway Solutions Minnesota Inc. reserves the right to revise the information presented or to discontinue the production of parts described at any time.

