

Pedal Actuated Integrated Tandem POWER BRAKE VALVE



Service Instructions

TABLE 1 (Specifications)

| Model Number | Repair Kit | High/Low Accumulator Pressure | | Brake Pressure | | Pressure Reducing Valve Pressure | |
|-----------------|------------|-------------------------------|-----------------------|-----------------------|-----------------------|----------------------------------|-----------|
| | | bar High (PSI) | bar Low (PSI) | bar (PSI) | bar (PSI) | bar (PSI) | bar (PSI) |
| 06-467-002 (HO) | 06-400-164 | 169 ± 3.5 (2450 ± 50) | 141 ± 3.5 (2050 ± 50) | 100 ± 5.2 (1450 ± 75) | 203 ± 3.5 (2950 ± 50) | | |
| 06-467-006 (HO) | 06-400-210 | 138 ± 3.5 (2000 ± 50) | 114 ± 3.5 (1650 ± 50) | 80 ± 3.5 (1160 ± 50) | None | None | |
| 06-467-008 (HO) | 06-400-210 | 138 ± 3.5 (2000 ± 50) | 114 ± 3.5 (1650 ± 50) | 95 ± 5.2 (1375 ± 75) | None | None | |
| 06-467-010 (HO) | 06-400-164 | 159 ± 3.5 (2300 ± 50) | 128 ± 3.5 (1850 ± 50) | 109 ± 5.2 (1575 ± 75) | 203 ± 3.5 (2950 ± 50) | | |
| 06-467-012 (HO) | 06-400-164 | 128 ± 3.5 (1850 ± 50) | 103 ± 3.5 (1500 ± 50) | 60 ± 3.5 (870 ± 50) | 203 ± 3.5 (2950 ± 50) | | |

HO = Mineral Base Hydraulic Oil

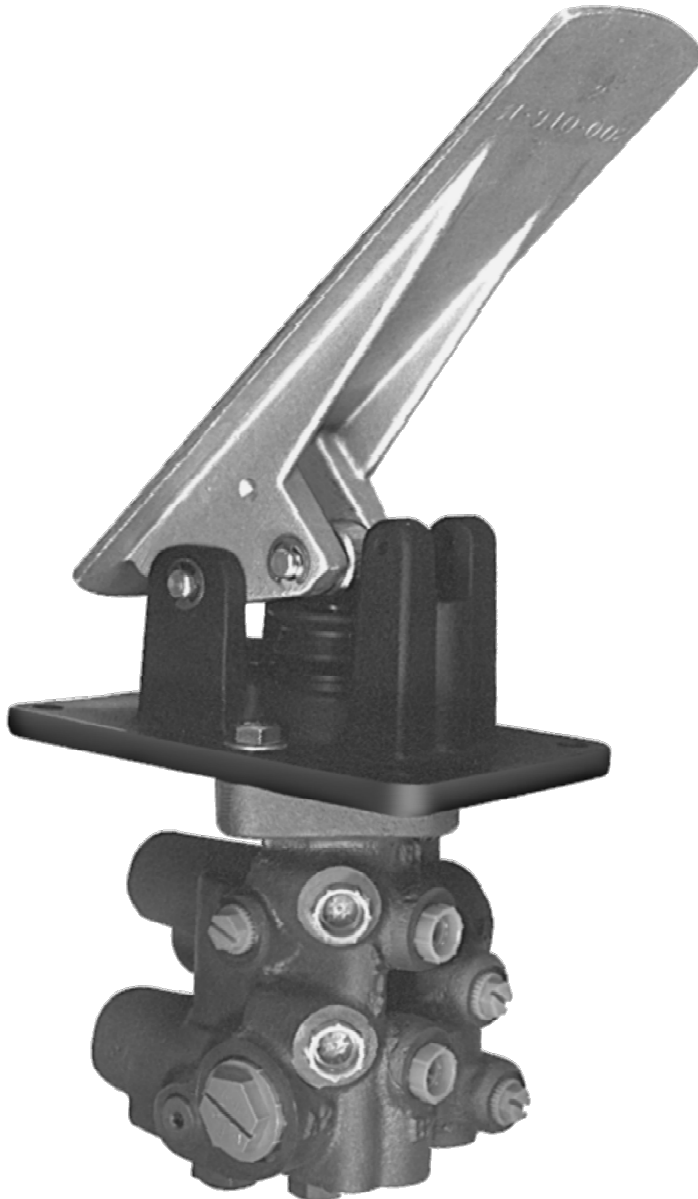

SEPARATING PEDAL FROM VALVE

(Refer to Figures 3 & 4)

1. Disconnect fluid lines and remove valve and pedal assembly from vehicle. Drain fluid from assembly. Note orientation of pedal to valve for reassembly purposes.
2. Separate pedal and valve by removing cap screws (1, 3 & 4) and washers (2). **NOTE:** Models shown in Figure 4, page 6, require the removal of set screw (18) and pin (19) before removing cap screw (4).

NOTE

For reassembly purposes, arrange the parts in the order in which they are removed while disassembling this valve.

VALVE DISASSEMBLY

(Refer to Figures 1 & 2, Page 5)

1. From cavity 3 on the bottom end of housing (51), remove end plug (35). Remove o-ring (36) from end plug.
2. Remove two springs (37), two poppets (38) and sleeve (40) from housing. **NOTE: Be careful not to scratch or mar sleeve or housing bore.**
3. Remove o-rings (39 & 41) from sleeve (40).
4. From cavity 2 on the bottom end of housing (51), remove plug (34). Remove o-ring (21) from plug.
5. Remove spring (33), stop (32) and ball (31) from housing. Note, spool (30) may or may not fall out at this point.
6. From cavity 2 on the top end of housing (51), remove plug (20). Remove o-ring (21) from plug.
7. BEFORE removing screw (23), ACCURATELY MEASURE ITS DEPTH FROM THE END OF HOUSING BORE and record for reassembly purposes. Remove screw (23) from housing.
8. Remove spring (24), retainer (25) and ball (26). Be sure to keep ball (26) separate from ball (31) for reassembling.
9. Remove pin (22) from screw (23) using a drive pin punch. Be careful not to damage threads.
10. Place housing (51) on bench with bottom end facing down. Using a 6.4 mm-7.9 mm (1/4-5/16 in) diameter wooden or plastic dowel, carefully remove insert (29) and spool (30) from housing. Insert (29) must be removed from bottom end of housing. **NOTE: Be careful not to scratch or mar valve seats on insert (29).**
11. Remove spool (30) from insert (29). Remove o-rings (27 & 28) from insert.
12. From cavity 1 on the bottom end of housing (51), remove

end plug (19). Remove o-ring (18) from end plug.

13. Remove spring (17) and spool (16) from housing. **NOTE: Be careful not to damage spool or housing bore.**

⚠ CAUTION

Spool (16) and housing (51) are manufactured as a matched set and cannot be intermixed with other parts.

14. From cavity 1 on the top end of housing (51), remove boot (1) from piston (2) and housing.
15. Remove piston (2), springs (4 & 5), retainer (6), springs (7 & 8), shim(s) (9) and retainer assembly (10) from housing (51). Not all models use spring (5), retainer (6), or spring (8). **NOTE: Be aware of the number of shim(s) removed from housing.**
16. Carefully remove quad ring (3) and retaining ring (11) from housing (51) bore. **NOTE: Be careful not to scratch housing bore.**
17. Remove washer (12) from housing.
18. Remove spool (15) from sleeve (14) inside housing.
19. Using a 3/4-16 UNF thread bolt, screw bolt into sleeve (14) and carefully pull sleeve from housing (51) through top end of housing. **NOTE: Be careful not to damage sleeve (14), spool (15) or housing bore.**

⚠ CAUTION

Sleeve (14) and spool (15) are manufactured as a matched set and cannot be intermixed with other parts.

20. Remove three o-rings (13) from sleeve (14).
21. From cavity 4 on the bottom end of housing (51), loosen nut (42) and remove screw assembly (43) from housing. Remove o-ring (44) from screw assembly.
22. Remove spring (37), poppet (45), seat (46) and o-ring (21) from housing.
23. From cavities 5 and 6 on the bottom end of housing (51),

remove plugs (47 & 49). Remove o-rings (48 & 50) from plugs.

24. From cavity 9, remove plug (47). Remove o-ring (48) from plug.
25. From cavities 7 and 8, remove plugs (20 & 47). Remove o-rings (21 & 48) from plugs. Not all models use plug assemblies in cavities 7 & 8.
26. From cavity 10 on the bottom end of housing (51), remove cartridge (52). **NOTE: Refer to Figure 2 for further instructions to disassemble cartridge (52).**
27. TO DISASSEMBLE CARTRIDGE (52) **OPTION A**, remove plug (53) from sleeve (54). Remove o-ring (21) from plug (53).
28. Remove o-rings (55 & 56), back-up ring (57) and o-ring (39) from sleeve (54). Note the location of o-rings and back-up ring.
29. TO DISASSEMBLE CARTRIDGE (52) **OPTION B**, remove plug (53), spring (58), shim(s) (59) and spool (60) from sleeve (61). **NOTE: Be aware of the number of shim(s) removed.**

⚠ CAUTION

Spool (60) and sleeve (61) are manufactured as a matched set and cannot be intermixed with other parts.

30. Remove o-ring (21) from plug (53).
31. Remove o-rings (55 & 56), back-up ring (57) and o-rings (39 & 41) from sleeve (61). Note the location of o-rings and back-up ring.
32. TO DISASSEMBLE CARTRIDGE (52) **OPTION C**, remove plug (53), rod (62), spring (63) and spool (64) from sleeve (65).

⚠ CAUTION

Spool (64) and sleeve (65) are manufactured as a matched set and cannot be intermixed with other parts.

33. Remove o-ring (21) from plug (53).
34. Remove o-rings (55 & 56), back-up ring (57) and o-rings (39 & 41) from sleeve (65). Note the location of o-rings and back-up ring.

VALVE ASSEMBLY

(Refer to Figures 1 & 2, Page 5)

LUBRICATE ALL RUBBER COMPONENTS FROM REPAIR KIT WITH CLEAN TYPE FLUID USED IN THE SYSTEM.

FOR EASE OF REASSEMBLY, SEPARATE AND MATCH NEW O-RINGS TO OLD O-RINGS, USE TABLE 2 TO IDENTIFY O-RING SIZES. NOT ALL O-RINGS WILL BE USED WITH ALL MODELS.

1. Thoroughly clean housing and all parts with clean solvent and allow to dry before proceeding. Lubricate all parts and housing bores with clean type fluid used in the system.
2. Install new o-ring (21) on plug (20) and install plug (20) in housing cavity 8. Not all models use plug (20) and o-ring (21) in cavity 8. Torque 47.5-54.2 N·m (35-40 lb·ft).
3. Install new o-ring (48) on plug (47) and install plug (47) in housing cavity 7. Not all models use plug (47) and o-ring (48) in cavity 7. Torque 13.6-19.0 N·m (10-14 lb·ft).
4. Install new o-ring (48) on plug (47) and install plug (47) in housing cavity 9. Torque 13.6-19.0 N·m (10-14 lb·ft).
5. Install new o-ring (50) on plug (49) and install plug (49) in housing cavity 6. Torque 7.4-8.5 N·m (65-75 lb·in).
6. Install new o-ring (48) on plug (47) and install plug (47) in housing cavity 5. Torque 13.6-19.0 N·m (10-14 lb·ft).
7. Install new o-ring (21) into cavity 4 on the bottom end of housing (51). Be sure o-ring is seated on bottom of bore.
8. Install seat (46), new poppet (45) and spring (37) into housing cavity 4.
9. Install new o-ring (44) on screw

assembly (43) and install screw assembly into housing cavity 4. Torque screw assembly 24.4-29.8 N·m (18-22 lb·ft). Torque nut (42) 43.4-51.5 N·m (32-38 lb·ft).

10. Install three new o-rings (13) on sleeve (14). Note direction of sleeve (14).
11. Install sleeve (14) into cavity 1 on the top end of housing (51). Install spool (15) in sleeve (13). Note direction of spool. **NOTE: Spool must slide freely into sleeve bore. If either spool or sleeve bore is damaged, a new spool/sleeve matched set may be required.**

⚠ CAUTION

Sleeve (13) and spool (15) are manufactured as a matched set and cannot be intermixed with other parts.

12. Install washer (12) into cavity (1).
13. Carefully install retaining ring (11) in bottom groove and new quad ring (3) into top groove of housing bore. **NOTE: Be careful not to scratch housing bore.**
14. Install retainer assembly (10), shim(s) (9), springs (8 & 7), retainer (6), springs (5 & 4) and piston (2) into cavity 1. Not all models use spring (8), retainer (6), or spring (5). Be sure to install the same number of shim(s) as were removed.
15. Install new boot (1) on housing (51) and piston (2).
16. Carefully slide spool (16) into cavity 1 on the bottom end of housing (51). Note direction of spool (16). **NOTE: Spool must slide freely into bore. If either spool or housing bore is damaged, a new spool/housing matched set may be required.**
17. Install new o-ring (18) on end plug (19).
18. Install spring (17) and end plug (19) into cavity 1. Torque 27.1-33.9 N·m (20-25 lb·ft).
19. Install new o-rings (28 & 27) on insert (29).
20. Install spool (30) into insert

- (29). Note direction of spool (30) and insert (29). Carefully install insert (29) into cavity 2 on the bottom end of housing (51).
21. Install new o-ring (21) on plug (34).
22. Insert ball (31), stop (32), spring (33) and plug (34) into cavity 2 on the bottom end of housing (51). Torque 47.5-54.2 N·m (35-40 lb·ft).
23. Position housing (51) so the bottom end faces down. Drop ball (26), retainer (25) and spring (24) into cavity 2 on the top end of housing (51).
24. Insert new pin (22) in screw (23). Be sure pin is aligned properly and is evenly driven into screw. Do not damage threads.
25. Thread screw (23) into cavity 2 on the top end of housing (51) TO THE DEPTH RECORDED during disassembly.
26. Install new o-ring (21) on plug (20) and install plug (20) into cavity 2. Torque 47.5-54.2 N·m (35-40 lb·ft).
27. Install new o-rings (39 & 41) on sleeve (40).
28. Install new o-ring (36) on end plug (35).
29. Install two springs (37), two new poppets (38), sleeve (40) and end plug (35) into cavity 3 on the bottom end of housing (51). Note the order and direction of components. Torque end plug (35) 47.5-54.2 N·m (35-40 lb·ft).
30. To continue with assembly procedures refer to Figures 1 & 2.
31. TO ASSEMBLE CARTRIDGE (52) **OPTION A**, install new o-ring (21) on plug (53) and install plug into sleeve (54). Torque 47.5-54.2 N·m (35-40 lb·ft).
32. Install new o-rings (55 & 56), new back-up ring (57) and new o-ring (39) on sleeve (54).
33. Install cartridge (52) into cavity 10 on the bottom end of housing (51). Torque 47.5-54.2 N·m (35-40 lb·ft).
34. TO ASSEMBLE CARTRIDGE (52) **OPTION B**, install new o-ring (21) on plug (53).

35. Install spool (60), shim(s) (59), spring (58) and plug (53) into sleeve (61). Torque 47.5-54.2 N·m (35-40 lb·ft). Note direction of spool (60). Be sure to install the same number

⚠ CAUTION

Spool (60) and sleeve (61) are manufactured as a matched set and cannot be intermixed with other parts.

of shim(s) as were removed.

36. Install new o-rings (55 & 56), new back-up ring (57) and new o-rings (39 & 40) on sleeve (61).
37. Install cartridge (52) into cavity 10 on the bottom end of housing (51). Torque 47.5-54.2 N·m (35-40 lb·ft).
38. TO ASSEMBLE CARTRIDGE (52) **OPTION C**, install new o-ring (21) on plug (53).
39. Install spool (64), spring (63), rod (62) and plug (53) into sleeve (65). Torque 47.5-54.2 N·m (35-40 lb·ft).

⚠ CAUTION

Spool (64) and sleeve (65) are manufactured as a matched set and cannot be intermixed with other parts.

TABLE 2 (Items Included in Repair Kit)

| Item Number | Description | Quantity |
|-------------|---|----------|
| 1 | Boot | 1 |
| 3 | Quad Ring, 1.296 I.D. x 1.574 O.D. x 0.139 Thick | 1 |
| 13 | O-Ring, 0.864 I.D. x 1.004 O.D. x 0.070 Thick | 3 |
| 18 | O-Ring, 0.468 I.D. x 0.624 O.D. x 0.078 Thick | 1 |
| 21 | O-Ring, 0.644 I.D. x 0.818 O.D. x 0.087 Thick | 5 |
| 22 | Pin | 1 |
| 27 | O-Ring, 0.301 I.D. x 0.441 O.D. x 0.070 Thick | 1 |
| 28 | O-Ring, 0.364 I.D. x 0.504 O.D. x 0.070 Thick | 1 |
| 36 | O-Ring, 0.799 I.D. x 1.005 O.D. x 0.103 Thick | 1 |
| 38 | Poppet | 2 |
| 39 | O-Ring, 0.676 I.D. x 0.816 O.D. x 0.070 Thick | 2 |
| 41 | O-Ring, 0.652 I.D. x 0.792 O.D. x 0.070 Thick | 2 |
| 44 | O-Ring, 0.755 I.D. x 0.949 O.D. x 0.097 Thick | 1 |
| 45 | Poppet | 1 |
| 48 | O-Ring, 0.351 I.D. x 0.495 O.D. x 0.072 Thick | 3 |
| 50 | O-Ring, 0.239 I.D. x 0.367 O.D. x 0.064 Thick | 1 |
| 55 | O-Ring, 0.924 I.D. x 1.156 O.D. x 0.116 Thick | 1 |
| 56 | O-Ring, 0.739 I.D. x 0.879 O.D. x 0.070 Thick | 1 |
| 57 | Back-Up Ring, 0.705 I.D. x 0.803 O.D. x 0.049 Thick | 1 |

NOTE: All dimensions in inches. Not all repair kit parts are used.

40. Install new o-rings (55 & 56), new back-up ring (57) and new o-rings (39 & 41) on sleeve (65).
41. Install cartridge (52) into cavity 10 on the bottom end of housing (51). Torque 47.5-54.2 N·m (35-40 lb·ft).

TO CONTINUE, REFER TO **PEDAL INSPECTION, ATTACHING PEDAL/BASE ASSEMBLY AND VALVE AND PLUNGER ADJUSTMENT** ON PAGE 6. (Use the proper instructions for your model.)

VALVE ADJUSTMENT

(Refer to Figures 1 & 2 and Table 2)

AFTER REASSEMBLING VALVE, ADJUSTMENTS MAY BE NECESSARY TO PRODUCE THE PRESSURE LEVELS SHOWN ON TABLE 1. THE UNIT MAY BE TESTED ON A HYDRAULIC BENCH BEFORE PEDAL ASSEMBLY IS ATTACHED.

TO ADJUST HIGH/LOW ACCUMULATOR PRESSURE

1. From cavity 2 on the top end of housing (51), remove plug (20).
2. Turn screw (23) until specified pressure is obtained.
3. Reinstall plug (20) and torque 47.5-54.2 N·m (35-40 lb·ft).

TO ADJUST BRAKE PRESSURE

1. From cavity 1 on the top end of housing (51), remove boot (1), piston (2), springs (4 & 5), retainer (6), springs (7 & 8), shim(s) (9) and retainer assembly (10). Not all models use spring (5), retainer (6), or spring (8).
2. To obtain specified pressure, remove or add additional shim(s) (9).
3. Reinstall retainer assembly (10), shim(s) (9), springs (8 & 7), retainer (6), springs (5 & 4), piston (2) and boot (1). Not all models use spring (8), retainer (6), or spring (5).

TO ADJUST PRESSURE REDUCING VALVE PRESSURE

-OPTION B (Options A & C are not adjustable)

1. At cavity 10 on the bottom end of housing (51), remove plug (53) and spring (58) from cartridge (52).
2. To obtain specified pressure, remove or add additional shim(s) (59) over flange of spool (60).
3. Reinstall spring (58) and plug (53). Torque plug 47.5-54.2 N·m (35-40 lb·ft).

This publication is not subject to any update service. Information contained in this publication was in effect at the time the publication was approved for printing and is subject to change without notice or liability. ZF Off-Highway Solutions Minnesota Inc. reserves the right to revise the information presented or to discontinue the production of parts described at any time.



ZF Off-Highway Solutions Minnesota Inc.
1911 Lee Boulevard / North Mankato, MN U.S.A. 56003
Tel: +1 507 625 6426 **Fax:** +1 507 625 3212

● Items included in repair kit

* Not used in all models

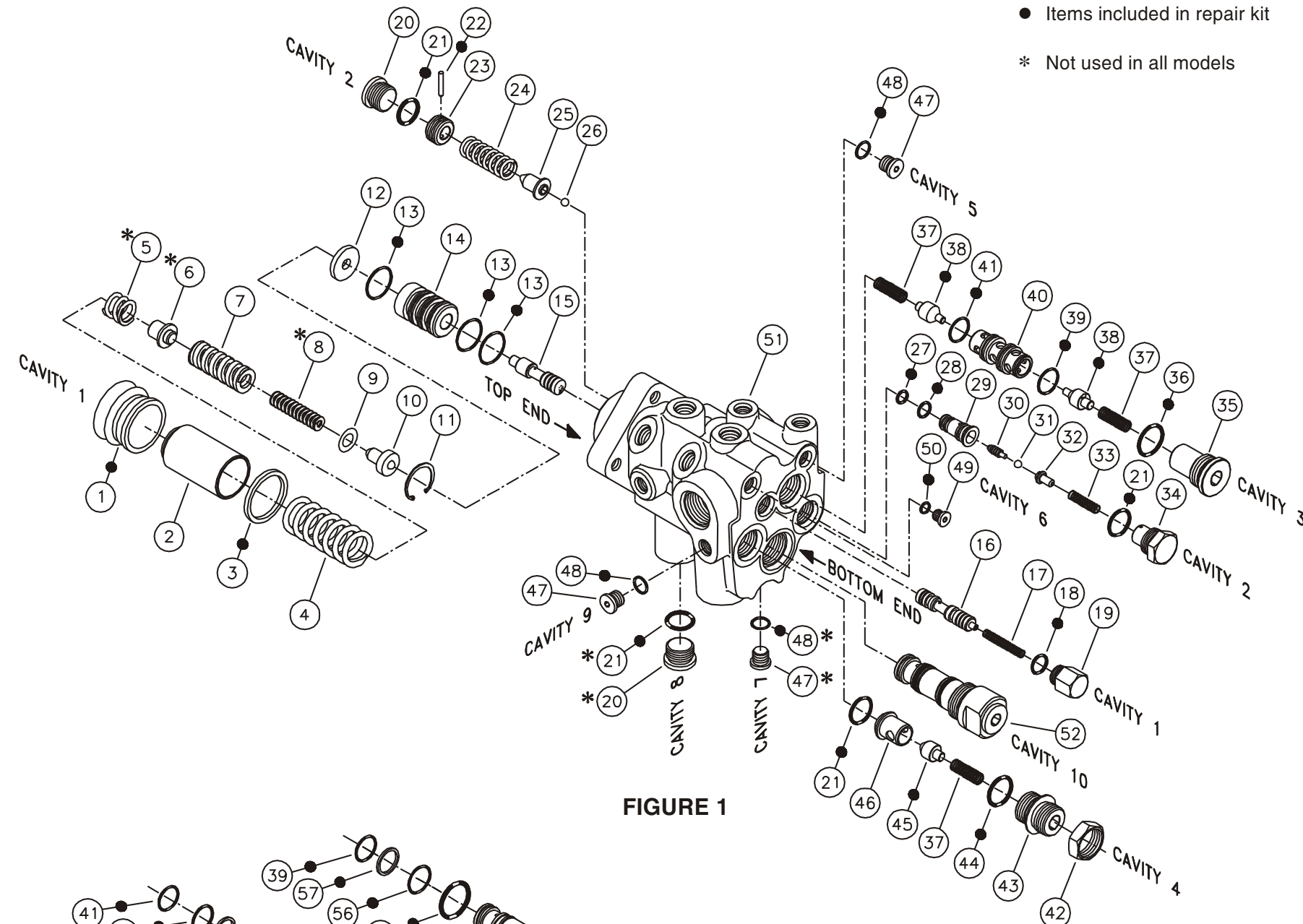
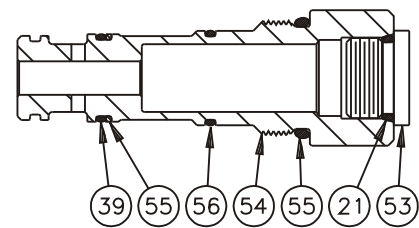
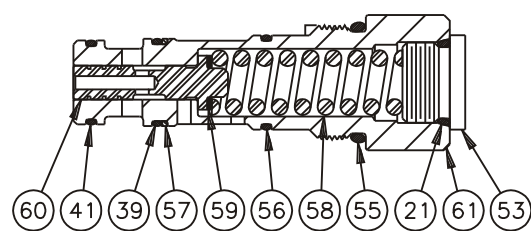

FIGURE 1

OPTION A - Section View



OPTION B - Section View



OPTION C - Section View

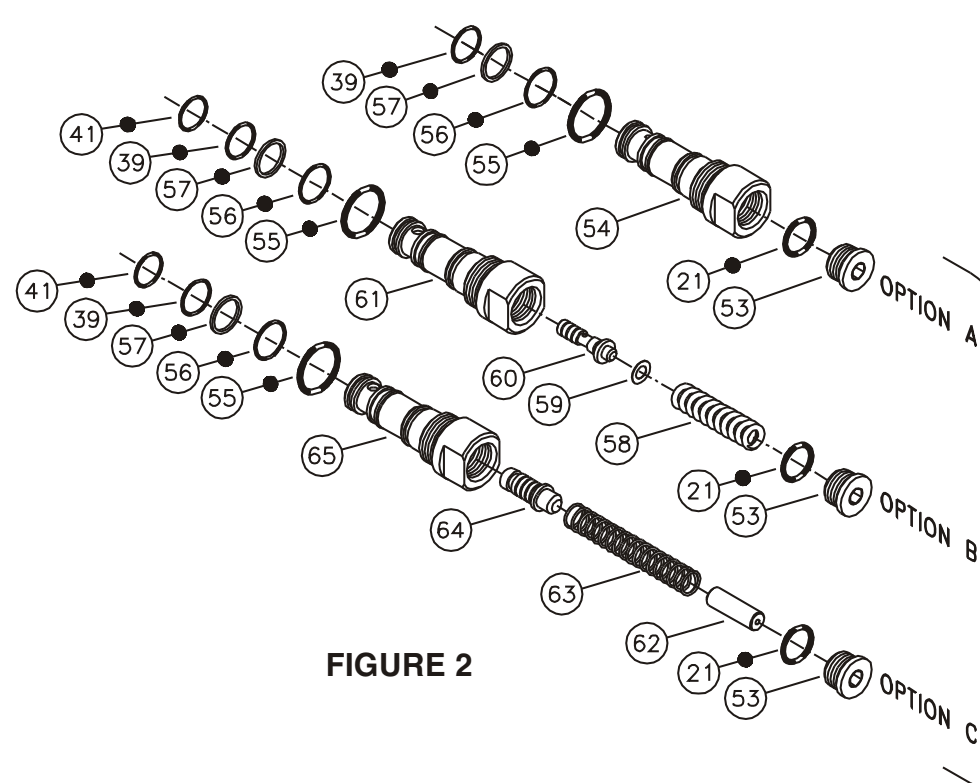
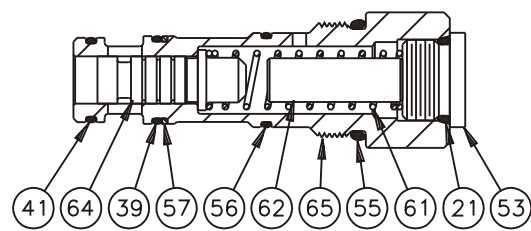

FIGURE 2

OPTION A - Cartridge (Plug only)
(Load Sense Model)

OPTION B - Pressure Reducing Cartridge
(Load Sense Model)

OPTION C - Open Center Cartridge
(Open Center Model)

| Model Number | Items not used | Cartridge (Item 52) |
|--------------|--|---------------------|
| 06-467-002 | Springs (5 & 8), Retainer (6), Plug (47) & O-ring (48) | OPTION B |
| 06-467-006 | Spring (8), Plug (20) & O-ring (21) | OPTION C |
| 06-467-008 | Spring (8), Plug (20) & O-ring (21) | OPTION C |
| 06-467-010 | Springs (5 & 8), Retainer (6), Plug (47) & O-ring (48) | OPTION B |
| 06-467-012 | Springs (5 & 8), Retainer (6), Plug (47) & O-ring (48) | OPTION B |

MODELS: 06-467-002
06-467-006
06-467-008
06-467-010
06-467-012

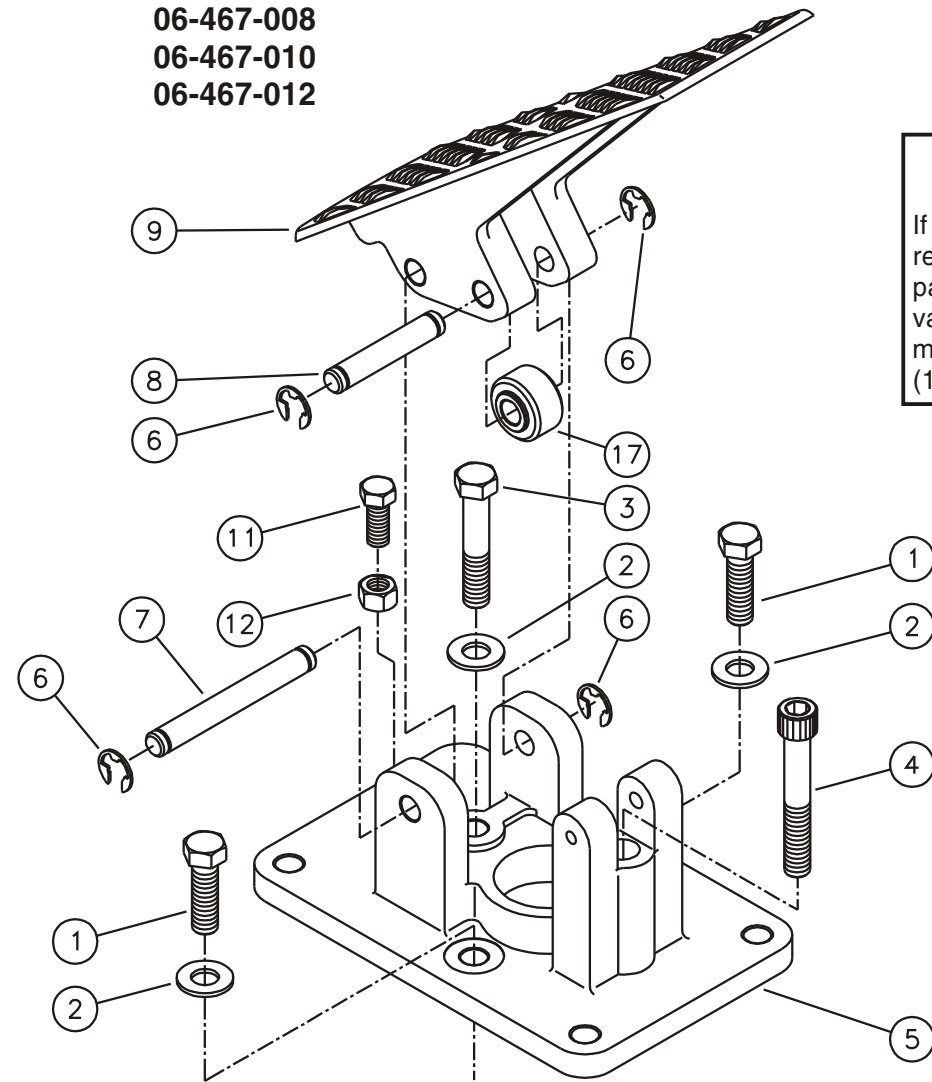

FIGURE 3

PEDAL INSPECTION

(Refer to Figure 3)

Thoroughly inspect pedal assembly components for damage or wear. Cam (17) and pin (8) must be in proper working order and move freely. Contact MICO, Inc. to replace parts that are damaged or worn. If pedal assembly is disassembled, lubricate pins (7 & 8) with moly base grease before reassembling.

ATTACHING PEDAL/BASE ASSEMBLY AND VALVE

Attach the pedal/base assembly and valve with bolts (1, 3 & 4) and washers (2). Torque bolts (1, 3 & 4) 47.5-54.2 N-m (35-40 lb-ft). Be sure orientation of pedal/base assembly to valve is correct.

NOTE
If cap screw (11) or nut (12) are loosened or removed, they must be reset properly. With all parts assembled, adjust screw (11) to allow the valve spool to fully release. After adjustment is made torque nut (12) 24.4-29.8 N-m (18-22 lb-ft).

MODELS:

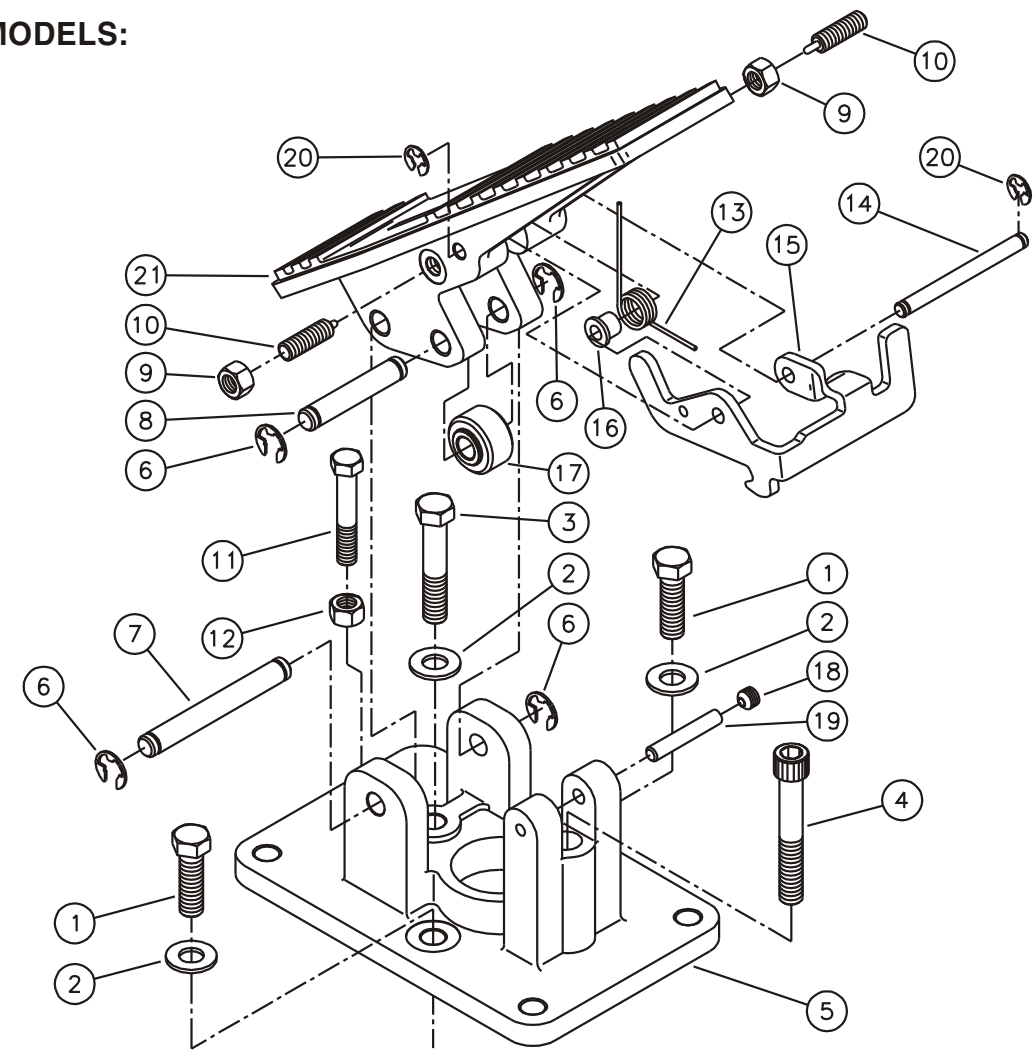

FIGURE 4

PEDAL INSPECTION

(Refer to Figures 4 & 5)

Thoroughly inspect pedal assembly components for damage or wear. Cam (17) and pin (8) must be in proper working order and move freely. Contact MICO, Inc. to replace parts that are damaged or worn. If pedal assembly is disassembled, lubricate pins (7, 8 & 14) with moly base grease before reassembling. Spring (13) must be compressed while it is being assembled.

ATTACHING PEDAL/BASE ASSEMBLY AND VALVE

Attach the pedal/base assembly and valve with bolts (1, 3 & 4) and washers (2). Torque bolts (1, 3 & 4) 47.5-54.2 N-m (35-40 lb-ft). Be sure orientation of pedal/base assembly to valve is correct. Install pin (19) and set screw (18).

PLUNGER ADJUSTMENT

(Refer to Figure 5)

1. If plunger(s) (10) or nut(s) (9) are loosened or removed, they must be reset properly.
2. Turn both plungers (10) in until bottoming on hook (15).
3. Back off each plunger 1/4-3/4 turn until dimension in DETAIL A is obtained and tighten nuts (9).

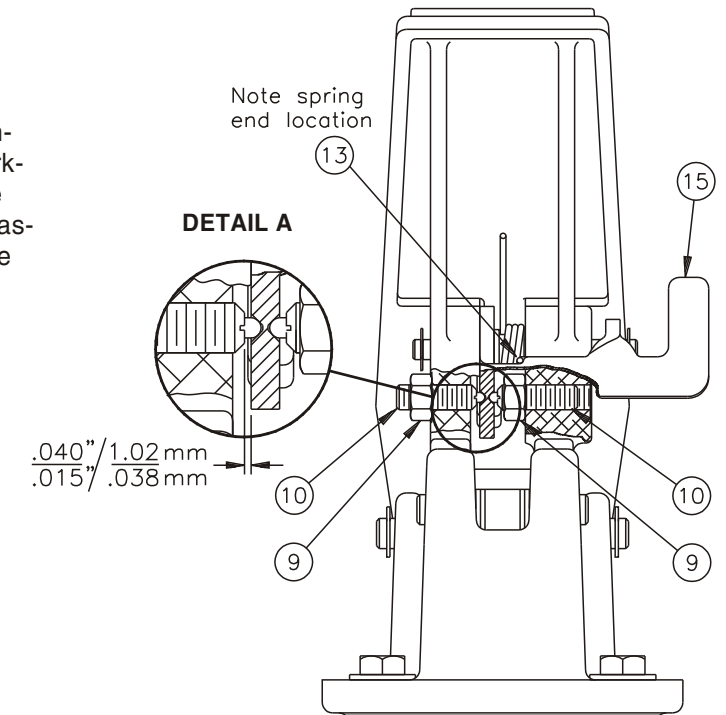

FIGURE 5