

# TANDEM MODULATING VALVE with Pilot Apply



## Service Instructions

**TABLE 1** (Specifications)

Model Number	Valve Assembly Number	Brake Pressure Setting	
		bar	(PSI)
06-466-445	20-200-068	158.6 ± 6.9	(2300 ± 100)

**NOTE:** If your product number is not listed, contact ZF Off-Highway Solutions Minnesota Inc. for information.

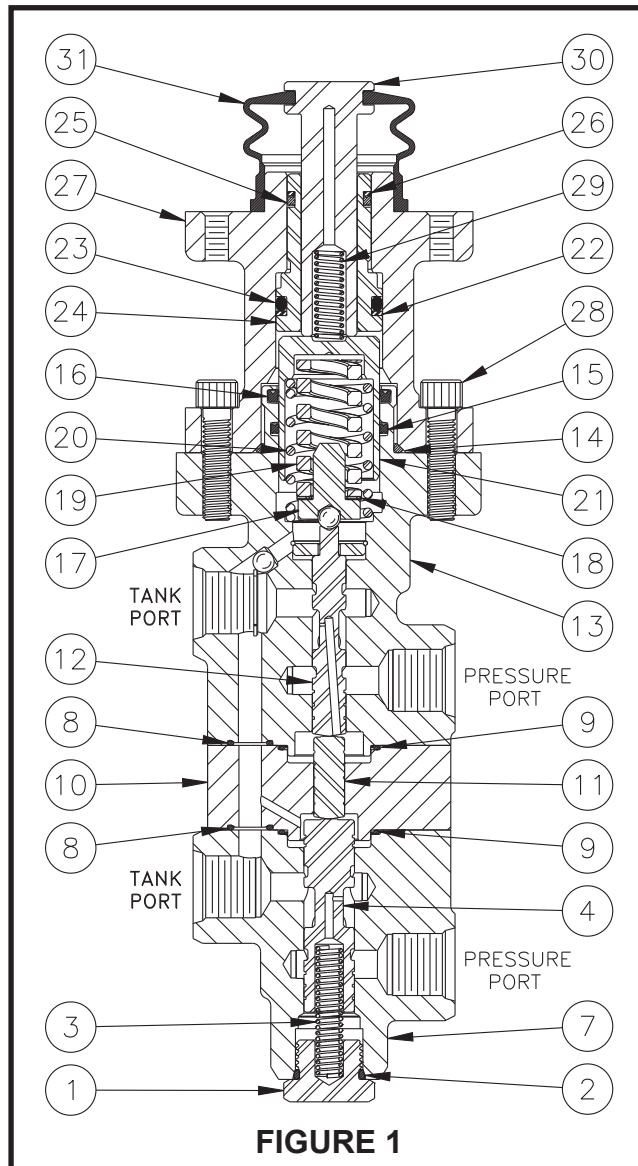

**Model: 06-466-445**

## DISASSEMBLY

(Refer to Figures 1 and 2)

### NOTE

Housing (7 & 13) and spools (4 & 12), spacer (10) and spool (11) are manufactured as matched sets.

1. Remove boot (31) from push rod (30) and pilot housing (27). Remove push rod (30) and spring (29) from pilot housing (27) bore.
2. Separate pilot housing (27) and housing (13) by removing cap screws (28). Remove o-ring (14) from housing (13).
3. Remove piston (24) from pilot housing (27). Piston must be removed through the bottom end of pilot housing (27). **NOTE: Be careful not to scratch or mar housing bore.**
4. Remove back-up ring (26), quad ring (25), back-up ring (22), and o-ring (23) from piston (24). **NOTE: Be careful not to damage the o-ring or back-up ring grooves.**
5. Remove piston (21), springs (19 & 20), shim(s) (18), and retainer assembly (17) from housing (13). Note the number of shim(s) (18) being removed from housing (13).
6. Carefully remove cup (16) and quad ring (15) from housing (13) bore. **NOTE: Be careful not to scratch or mar housing bore.**
7. Remove end plug (1) and spring (3) from housing (7). Remove o-ring (2) from end plug (1).
8. Separate housing (7 & 13) and spacer (10) by removing cap screws (5) and washers (6). Remove two o-rings (8) and two o-rings (9).
9. Carefully remove spools (4 & 12) from housing (7 & 13) and spool (11) from spacer (10). **NOTE: Be careful not to damage spools or housing bores.**

### CAUTION

Do not intermix spools and housings. Spool (4) and housing (7) are a matched set, as well as spool (12) and housing (13), and spool (11) and spacer (10).

5. Reassemble housing (7 & 13) and spacer (10) using cap screws (5) and washers (6). Use Loctite 242 on cap screws (5) and torque 29.8-33.9 N·m (22-25 lb·ft). **NOTE: Make sure the housings line-up correctly and o-rings (8 & 9) remain in the pockets during assembly.**
6. Lubricate spool (4) with clean system fluid and carefully slide into housing (7) bore. Note direction of spool (4). **NOTE: Spool must slide freely into housing bore. If either part is damaged, a new valve assembly may be required.**
7. Install new o-ring (2) on plug (1). Install spring (3) and end plug (1) into housing (7). Torque end plug (1) 47.5-54.2 N·m (35-40 lb·ft).
8. Carefully install new quad ring (15) and new cup (16) in housing (13) bore. Note direction and order of cup (16) and quad ring (15). **NOTE: Be careful not to scratch or mar housing bore.**
9. Assemble springs (19 & 20), shim(s) (18), and retainer assembly (17) in piston (21).
10. Carefully install piston (21) assembly into housing (13) bore.
11. Install new o-ring (23), new back-up ring (22), new quad ring (25), and new back-up ring (26) on piston (24). Note order of o-ring (23), back-up rings (22 & 26), and quad ring (25).
12. Install piston (24) into pilot housing (27) bore from the bottom end. Be sure piston (24) is fully seated into pilot housing (27) bore.
13. Install new o-ring (14) on housing (13).
14. Carefully attach pilot housing (27) to housing (13) using two cap screws (28). Torque cap screws (28) 27.1-33.9 N·m (20-25 lb·ft).
15. Install spring (29) and push rod (30) into pilot housing (27) bore.
16. Install new boot (31) on push rod (30) and pilot housing (27).

### NOTE

After service, the valve must develop the pressure indicated in the specifications, TABLE 1. Shim(s) (18) are used to obtain the correct pressure setting. Contact ZF Off-Highway Solutions Minnesota Inc. if brake pressure setting is not able to be obtained.

## ASSEMBLY

(Refer to Figures 1 and 2)

LUBRICATE ALL RUBBER COMPONENTS FROM THE REPAIR KIT WITH CLEAN TYPE FLUID USED IN THE SYSTEM.

1. Clean all parts thoroughly before assembling.
2. Lubricate spool (12) with clean system fluid and carefully slide into bottom end of housing (13) bore. Note direction of spool (12). **NOTE: Spool must slide freely into housing bore. If either part is damaged, a new valve assembly may be required.**
3. Lubricate spool (11) and carefully slide into spacer (10). **NOTE: Spool must slide freely into housing bore. If either part is damaged, a new valve assembly may be required.**
4. Install two new o-rings (8) and two new o-rings (9) in the proper o-ring pockets on housings (7 & 13) and spacer (10).

● Items included in Repair Kit 06-400-348

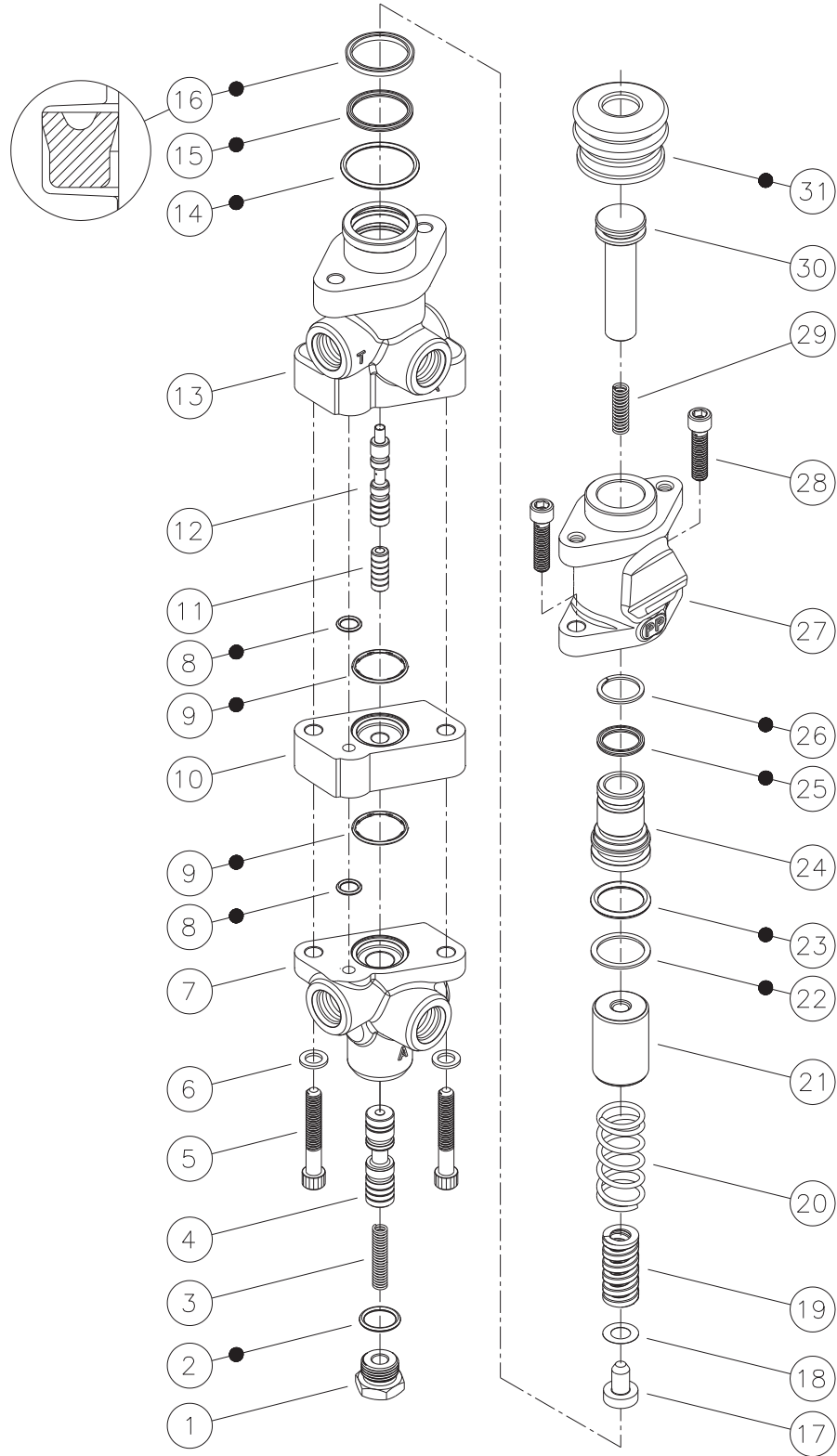

FIGURE 2

## BLEEDING

Brake lines should be bled very carefully as soon as the valve is installed in the machine. Air in the system will not allow the brakes to release properly and may severely damage them.

1. Start engine and allow accumulator to reach full charge. Shut down engine, and then slowly apply and release brakes, waiting one minute between applications until brakes will not apply. Repeat this step three times.

2. Operate engine to maintain accumulator pressure within working limits throughout the bleeding procedure.
3. Open bleeder screw at wheel closest to brake valve and apply brakes cautiously until all air is bled out of line. Then close bleeder screw. Repeat this step at each wheel, moving to the next farthest wheel from the brake valve each time, as follows:
  - a. Left front
  - b. Right front

- c. Right rear
  - d. Left rear
4. Release brake pressure for at least one (1) minute.
  5. Apply brakes, holding pedal down 10 seconds; then release pressure for one (1) minute. Repeat this step two more times.
  6. Repeat step 3.
  7. Check for system leaks and be sure of proper brake operation.

## SERVICE CHECKS FOR 466 SERIES TANDEM MODULATING VALVES

### BRAKES SLOW TO APPLY

1. No or improper gas charge in accumulator
1. **Check gas charge**
2. Brakes not properly adjusted
2. **Adjust brakes**
3. Inoperative brakes
3. **Check brakes**
4. Hydraulic lines or fittings leaking
4. **Check for leaks and repair**
5. Inoperative automatic adjuster
5. **Check adjuster operation**
6. Damaged hydraulic brake lines
6. **Check lines for dents that restrict flow of oil**

### INSUFFICIENT BRAKES

1. No oil or low oil level in tank
1. **Check oil level in tank**
2. Brakes not properly adjusted
2. **Check brake adjustment**
3. Oil or grease on brake lining
3. **Clean or install new linings**
4. Brake line damaged
4. **Check lines and replace**
5. Inoperative automatic adjusters
5. **Check operation of adjusters**
6. No or improper gas charge in accumulator
6. **Check gas charge**
7. Inoperative brakes
7. **Check brakes**

## SERVICE DIAGNOSIS

(Refer to Figures 1 and 2)

### BRAKES WILL NOT RELEASE COMPLETELY

1. Piston (21) binding.
2. Pedal angle out of adjustment.
3. Spring (3) broken.

### BRAKES WILL NOT RELEASE

1. Binding spools (4 & 12).
2. Piston (21) binding.

8. Brake valve inoperative
8. **Replace valve**
9. Inoperative system relief valve
9. **Check pressure in pressure line to valve**
10. Worn pump
10. **Check pressure in pressure line to valve**

### EXCESSIVE BRAKING

1. Inoperative brakes
1. **Check brakes**
2. Inoperative brake valve
2. **Replace brake valve**

### BRAKES WILL NOT RELEASE COMPLETELY

1. Brakes not properly adjusted
1. **Adjust brakes**
2. Inoperative brakes
2. **Check brakes**
3. Pedal angle out of adjustment
3. **Adjust pedal angle**
4. Inoperative wheel cylinders
4. **Replace wheel cylinders**
5. Inoperative automatic adjuster
5. **Check operation of adjusters**
6. Air in brakes (when automatic adjusters used Goodrich Hi-torque Brakes only)
6. **Bleed brakes**

### NO BRAKES

1. Piston (21) binding.
2. Broken spring (19).

### OUTLET PRESSURE TOO HIGH (EXCESSIVE BRAKING)

1. Too many shims (18) installed in valve.

### EXCESSIVE ACCUMULATOR LEAKAGE WHEN BRAKES ARE APPLIED

1. Damaged spools (4 & 12).
2. Damaged housings (7 & 13).

### EXCESSIVE ACCUMULATOR LEAKAGE WHEN BRAKES ARE NOT BEING USED

1. Damaged spools (4 & 12).
2. Damaged housings (7 & 13).

### INSUFFICIENT BRAKES

1. Broken spring (19).
2. Pedal travel is inhibited.

This publication is not subject to any update service. Information contained in this publication was in effect at the time the publication was approved for printing and is subject to change without notice or liability. ZF Off-Highway Solutions Minnesota Inc. reserves the right to revise the information presented or to discontinue the production of parts described at any time.

