

Pedal Position Sensor

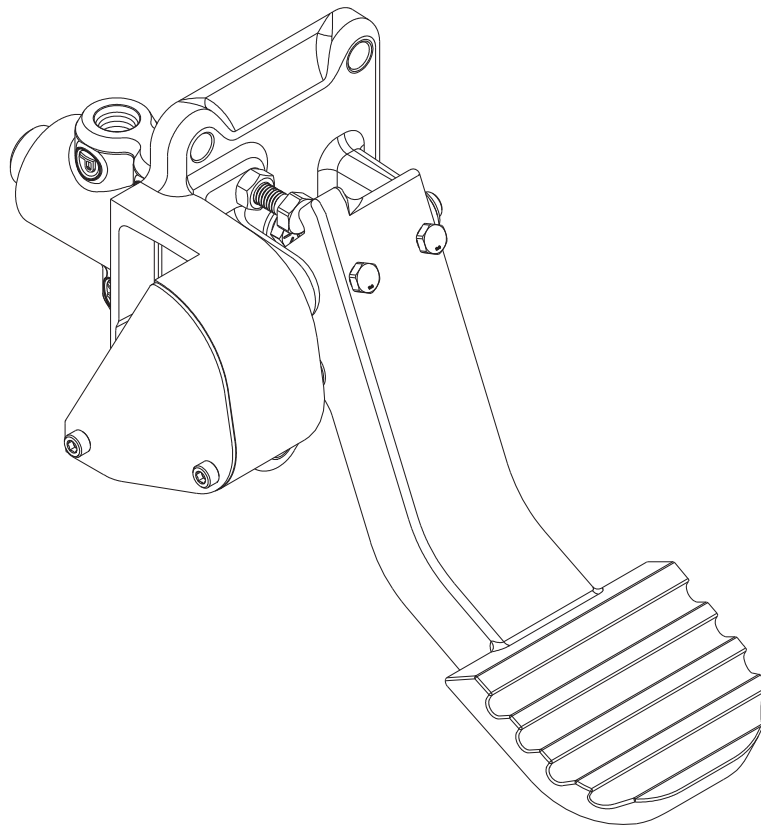

Service Instructions



This publication is not subject to any update service. Information contained in this publication was in effect at the time the publication was approved for printing and is subject to change without notice or liability. ZF Off-Highway Solutions Minnesota Inc. reserves the right to revise the information presented or to discontinue the production of parts described at any time.



DISASSEMBLY

(Refer to Figure 1)

1. Remove socket head cap screws (1) and cover (2).
2. Remove screws (3), washers (4), sensor (5) and coupling (6).
3. Remove cap screws (12) from pedal (13).
4. Remove e-ring (10) from pivot pin (9). Remove pivot pin (9) to separate pedal (13) and base assembly (8). Shim(s) (11) are removed during this step. Be aware of the number of shim(s) (11) removed for reassembly purposes.
5. Remove bushings (7) from base assembly (8).

● Items included in Repair Kit

ASSEMBLY

(Refer to Figure 1)

1. Install new bushings (7) in base assembly (8).
2. Apply Loctite 242 or equivalent to threads of new screws (3). Install coupling (6), new sensor (5), new washers (4), and new screws (3). Torque screws (3) 1.7-2.3 N·m (10-20 lb·in).
3. Lubricate the end of new pivot pin (9) with oil as shown in Figure 1. Install new pivot pin (9), shim(s) (11) and carefully reassemble pedal (13) to base assembly (8). Be sure to install the same number of shim(s) (11) as were removed. Be sure pivot pin (9) is properly positioned into coupling (6). Install e-ring (10).
4. Apply Loctite 242 or equivalent to threads of new cap screws (12). Install new cap screws (12) in pedal (13) but do not tighten against pivot pin (9). Pivot pin (9) must be able to rotate to adjust new sensor (5).
5. This step is for setting the adjustment of new sensor (5).
 - a. Connect sensor (5) pins A and E to ground. Connect 5 Vdc to pins B and F. Output is pin C and D.
 - b. Depress pedal (13) to the fully applied position. Use the index flat end of pivot pin (9) and rotate pivot pin (9) to get 1.5 Vdc at pin C and D. Hold pivot pin (9) in this position and torque cap screws (12) 5.7-6.2 N·m (45-55 lb·in). Verify output remained at 1.5 Vdc.
 - c. Return pedal (13) to the non-applied position. Pin C and D should have 3.5 Vdc. If not, loosen pedal stop nut and turn adjustment screw until 3.5 Vdc is achieved. Torque pedal stop nut 20.3-27.1 N·m (15-25 lb·ft).
 - d. Fully apply pedal (13) and allow it to freely return to the pedal stop three times. Pedal must move freely and return to the pedal stop in less than one second travel time.
6. Apply Loctite 242 to threads of socket head cap screws (1). Install cover (2) and socket head cap screws (1). Torque socket head cap screws (1) 1.7-2.8 N·m (15-25 lb·in).
7. Reconnect wire harness to the pedal and base assembly. Be sure electrical circuit is functioning properly.

