

# PEDAL ACTUATED Power Brake Valves

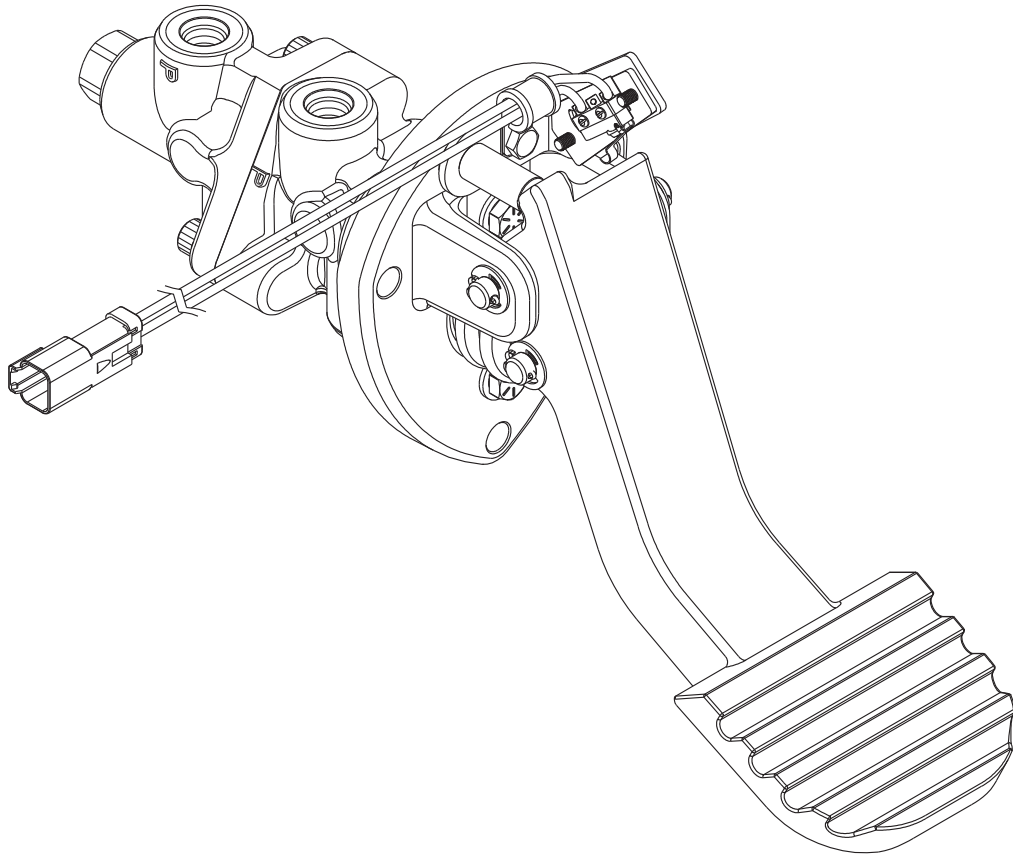

## Service Instructions



This publication is not subject to any update service. Information contained in this publication was in effect at the time the publication was approved for printing and is subject to change without notice or liability. ZF Off-Highway Solutions Minnesota Inc. reserves the right to revise the information presented or to discontinue the production of parts described at any time.



## PEDAL DISASSEMBLY

(Refer to Figure 1)

1. Separate pedal (1) from pedal base (5) by removing one cotter pin (4) and one e-ring (3) from pin (2) and sliding pin (2) from pedal base (5).  
**For Switch Kit service**, retain these parts for reassembly.  
**For Repair Kit service**, discard cotter pin (4), e-ring (3), and pin (2).
2. **For Switch Kit service**, it is unnecessary to remove bushings (6) from pedal base (5) unless replacement is necessary.  
**For Repair Kit service**, remove two bushings (6) from pedal base (5) and discard.
3. **For Switch Kit service**, inspect pin (7) and cam (8) to make sure cam is in good working order and moving freely. It is unnecessary to remove pin (7) or cam (8) unless replacement is necessary.  
**For Repair Kit service**, remove pin (7), cam (8), and discard.
4. **For Switch Kit service**, remove cap screws (9), screws (11), nuts (14), harness and switch (10), and insulator (13). Note, disassembly of stop (20), bracket (19), spacer (18), bracket (17), lock washers (16), and screws (15) is unnecessary unless replacement is required. Be aware that spacer (18) may slide out of position.  
**For Repair Kit service**, discard step 4.
5. Separate valve assembly from pedal base (5) by removing cap screws (21) and washers (22)

4. **For Switch Kit service**, install clamp (12) on new harness. Reposition spacer (18) if necessary and attach clamp (12) to pedal base (5) using cap screw (9). Torque cap screw (9) 13.6-20.3 N·m (10-15 lb·ft).  
**For Repair Kit service**, discard step step 4.
5. **For Switch Kit service**, discard step step 5.  
**For Repair Kit service**, Install new pin (7), new cam (8), two new e-rings (3), and two new cotter pins (4) on pedal (1).
6. **For Switch Kit service**, align pedal (1) between ears of pedal base (5) and install pin (2). Install e-ring (3) and new cotter pin (4).  
**For Repair Kit service**, install two new bushings (6) in pedal base (5). Align pedal (1) between ears of pedal base (5) and install new pin (2). Install two new e-rings (3) and two new cotter pins (4).
7. After reinstalling valve/pedal assembly on machine, check to be brake light switch is functioning properly.
8. If the switch is not functioning properly, adjustment of bracket (17) may be needed. Loosen screws (15) and adjust brake light switch so you hear a click of the snap action switch at approximately 3° pedal travel. Apply Loctite 222 or equivalent and torque screws (15) 13.6-20.3 N·m (10-15 lb·ft).

## PEDAL ASSEMBLY

(Refer to Figure 1)

1. Clean all parts thoroughly before reassembling.
2. Attached valve assembly to pedal base (5) using cap screws (21) and washers (22). Torque cap screws 24.4-29.8 N·m (18-22 lb·ft).
3. **For Switch Kit service**, install insulator (13), and new harness and switch (10) using new screws (11) and new nuts (14). Apply Loctite 222 or equivalent to threads of screws (11). Torque screws (11) while securely holding nuts (14) 0.23-0.57 N·m (2-5 lb·in).  
**For Repair Kit service**, discard step step 3.

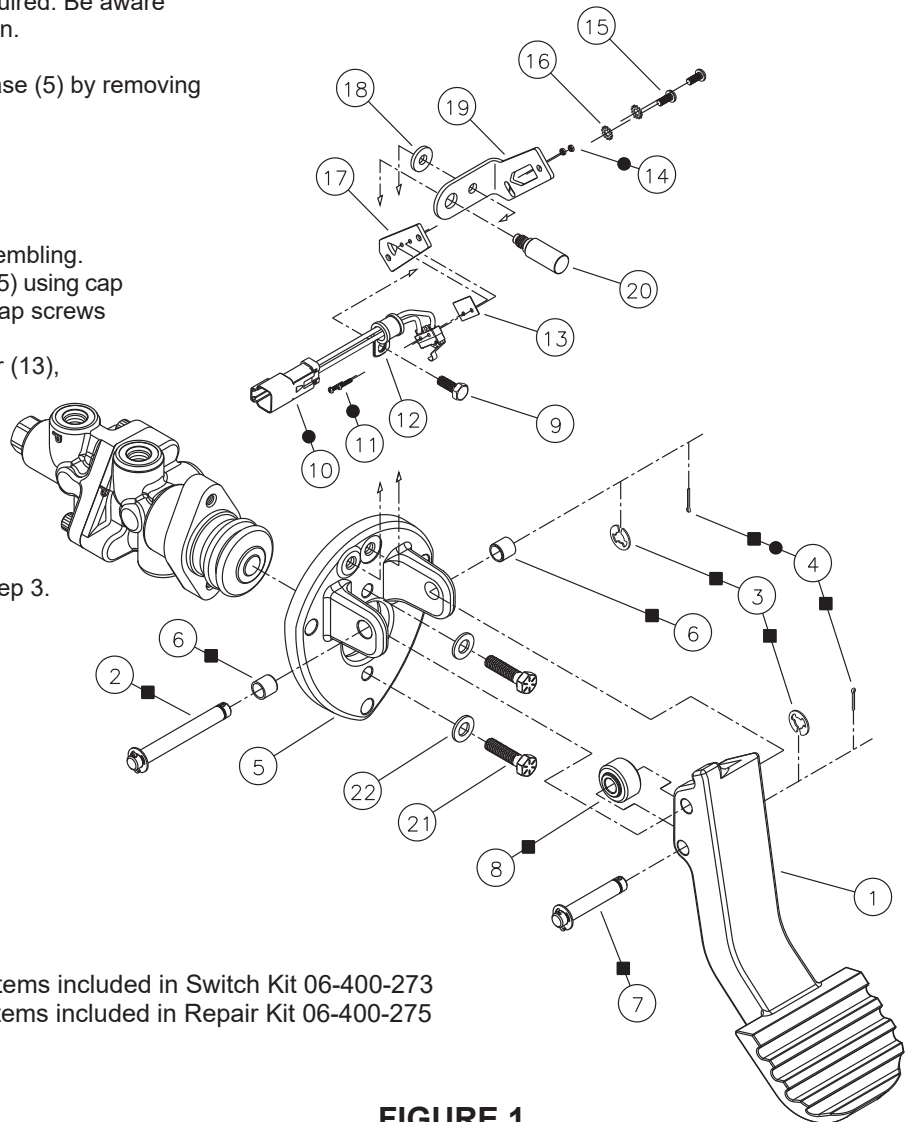

FIGURE 1