

Priority/Charging Valve



Service Instructions

TABLE 1 (Specifications)

Model Number	Type	Repair Kit Number	Nominal Accumulator Charge Rate 69.0 bar @ (1000 PSI)		Accumulator High Limit		Accumulator Low Limit		Relief Valve Setting	
			L/min	(GPM)	bar	(PSI)	bar	(PSI)	bar	(PSI)
20-100-597	Single	06-400-177	7.57 ± 1.89	(2.00 ± .5)	134.5 ± 3.5	(1950 ± 50)	74.1 ± 3.5	(1075 ± 50)	168.9 ± 6.9	(2450 ± 100)
20-100-605	Single	06-400-177	7.57 ± 1.89	(2.00 ± .5)	193.0 ± 3.5	(2800 ± 50)	132.7 ± 3.5	(1925 ± 50)	206.8 ± 3.5	(3000 ± 50)
20-100-606	Single	06-400-177	4.28 ± 1.44	(1.13 ± 0.38)	186.2 ± 3.5	(2700 ± 50)	141.3 ± 3.5	(2050 ± 50)	203.4 ± 3.5	(2950 ± 50)
20-100-639	Single	06-400-177	3.60 ± 0.95	(0.95 ± 0.25)	134.5 ± 3.5	(1950 ± 50)	74.1 ± 3.5	(1075 ± 50)	168.9 ± 6.9	(2450 ± 100)
20-100-640	Single	06-400-177	7.57 ± 1.89	(2.00 ± .5)	193.0 ± 3.5	(2800 ± 50)	132.7 ± 3.5	(1925 ± 50)	206.8 ± 3.5	(3000 ± 50)
20-100-641	Single	06-400-177	4.28 ± 1.44	(1.13 ± 0.38)	186.2 ± 3.5	(2700 ± 50)	141.3 ± 3.5	(2050 ± 50)	203.4 ± 3.5	(2950 ± 50)
20-100-758	Dual	06-400-250	4.28 ± 1.44	(1.13 ± 0.38)	186.2 ± 3.5	(2700 ± 50)	141.3 ± 3.5	(2050 ± 50)	203.4 ± 3.5	(2950 ± 50)

NOTE: If your product number is not listed, contact ZF Off-Highway Solutions Minnesota Inc. for information.

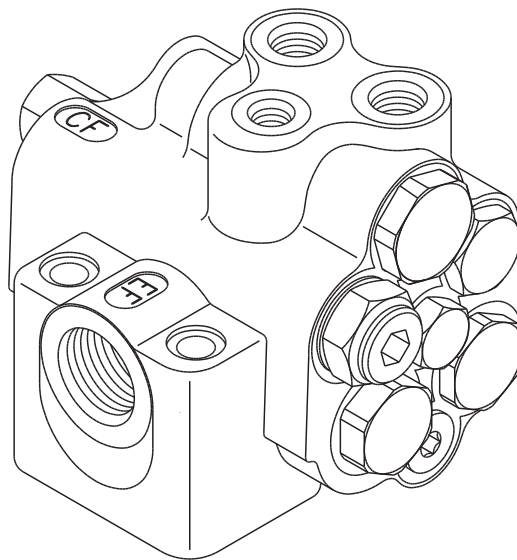

This publication is not subject to any update service. Information contained in this publication was in effect at the time the publication was approved for printing and is subject to change without notice or liability. ZF Off-Highway Solutions Minnesota Inc. reserves the right to revise the information presented or to discontinue the production of parts described at any time.



ZF Off-Highway Solutions Minnesota Inc.
 1911 Lee Boulevard / North Mankato, MN U.S.A. 56003
Tel: +1 507 625 6426 **Fax:** +1 507 625 3212

NOTE

For reassembly purposes, arrange the parts in the order in which they are removed while disassembling the valve. While removing this valve from the vehicle o-rings (16 & 48) may drop out of their pockets in housing (53). Orifice (49) need not be removed from housing (53).

VALVE DISASSEMBLY

(Refer to Figure 1)

1. Remove valve assembly from machine by removing cap screws (54 & 55). Remove o-rings (16 & 48). Drain fluid from the valve.
2. From cavity 7 remove plug (1). Remove o-ring (2) from plug (1).
3. From cavity 7 remove spring (3), poppets (4), sleeve (6) and spring (8). **NOTE: Be careful not to scratch housing or sleeve bore. Not all models use spring (3), poppets (4), sleeve (6) or spring (8).**
4. Remove o-rings (5 & 7) from sleeve (6). **NOTE: Not all models use sleeve (6) or o-rings (5 & 7).**
5. From cavity 6 remove end plug (9), spring (11), stop (12), and ball (13) from housing (53). Remove o-ring (10) from end plug (9). Note, spool (14) may or may not fall out at this point.
6. Remove plug (23) from housing (53). Remove o-ring (10) from plug (23).
7. BEFORE removing screw (21), ACCURATELY MEASURE ITS DEPTH FROM THE END OF HOUSING BORE and record for reassembly purposes. Remove screw (21) from housing (53).
8. Remove spring (20), retainer (19), and 1/4 inch diameter ball (18) from housing. Be sure to keep 1/4 inch diameter ball (18), ball (13), and ball (44) separate from one another.
9. Remove pin (22) from screw (21) using a drive pin punch. Be careful not to damage the threads.
10. Using a 6.4 mm (1/4 in) wooden or plastic dowel, carefully remove spool (14) and insert (15) from housing. **NOTE: Be careful not to scratch or mar valve seats on spool (14).**
11. Remove spool (14) from insert (15). Remove o-rings (16 & 17) from insert (15).
12. From cavity 5 remove plug (24) from housing (53). Remove o-ring (25) from plug (24).
13. Remove plug (30), spring (29), shim(s) (28), retainer (27) and piston (26) from housing. Remove o-ring (25) from plug (30). Note the number of shim(s) removed for reassembly purposes.
14. From cavity 4 remove plug (31) from housing. Remove o-ring (32) from plug (31).
15. Remove plug (35), spring (34), and spool (33) from housing (53). Remove o-ring (32) from plug (35). **NOTE: Earlier design used a two piece spool (33). It is not necessary to disassemble these parts.**
16. From cavity 3 remove plug (36) from housing (53). Remove o-ring (32) from plug (36).
17. From cavity 2 remove plug (37), spring (38), and spool (39) from housing (53). Remove o-ring (25) from plug (37).
18. Remove plug (40) from housing (53). Remove o-ring (25) from plug (40).
19. From cavity 1 loosen nut (41) and remove screw (42), spring (43), 7/16 inch diameter ball (44), seat (45), o-ring (10), washer (46), and filter (47) from housing (53). Remove o-ring (25) from screw (42).

20. From cavity 8 remove plug (50). Remove o-ring (51) from plug (50).
21. From cavity 10 remove plug (52). Remove o-ring (51) from plug (52).

VALVE ASSEMBLY

(Refer to Figure 1)

LUBRICATE ALL RUBBER COMPONENTS FROM REPAIR KIT WITH CLEAN TYPE FLUID USED IN THE SYSTEM.

FOR EASE OF REASSEMBLY, SEPARATE AND MATCH NEW O-RINGS TO OLD O-RINGS. USE TABLE 2 TO IDENTIFY O-RING SIZES.

1. Thoroughly clean housing and all parts with clean solvent and allow to dry before proceeding. Lubricate all parts and housing bores with clean type fluid used in the system.
2. Install new o-ring (51) on plug (52). Install plug (52) in housing cavity 10 and torque 13.6-19.0 N·m (10-14 lb·ft).
3. Install new o-ring (51) on plug (50). Install plug (50) in housing cavity 8 and torque 13.6-19.0 N·m (10-14 lb·ft).
4. Install new o-ring (25) on screw (42).
5. Install new filter (47), washer (46), new o-ring (10), seat (45), 7/16 inch diameter ball (44), spring (43), and screw (42) in cavity 1 of housing. Torque screw (42) 24.4-29.8 N·m (18-22 lb·ft).
6. Torque nut (41) 43.4-51.5 N·m (32-38 lb·ft).
7. Install new o-ring (25) on plug (40). Install plug (40) in housing cavity 2 and torque 54.2-61.0 N·m (40-45 lb·ft).
8. Install new o-ring (25) on plug (37). Install spool (39), spring (38), and plug (37) in housing cavity 2. Note the direction of spool (39). Torque plug (37) 54.2-61.0 N·m (40-45 lb·ft).
9. Install new o-ring (32) on plug (36). Install plug (36) in housing cavity 3 and torque 27.1-32.5 N·m (20-24 lb·ft).
10. Install new o-ring (32) on plug (35). Carefully install spool (33), spring (34), and plug (35) in housing cavity 4. Note direction of spool (33). Torque plug (35) 27.1-32.5 N·m (20-24 lb·ft).
11. Install new o-ring (32) on plug (31). Install plug (31) in housing cavity 4 and torque 27.1-32.5 N·m (20-24 lb·ft).
12. Install new o-ring (25) on plug (24). Install plug (24) in housing cavity 5 and torque plug (24) 54.2-61.0 N·m (40-45 lb·ft).
13. Install new o-ring (25) on plug (30).
14. Install retainer (27), shim(s) (28), and spring (29) on the stem of piston (26) and install into housing cavity 5. Install plug (30) and torque 54.2-61.0 N·m (40-45 lb·ft). Be sure to install the same number of shim(s) as were removed during disassembly.
15. Install new o-rings (17 & 16) on insert (15).
16. Install spool (14) into insert (15). Note the direction of spool (14) and insert (15). Carefully install insert (15) into housing cavity 6.
17. Install new o-ring (10) on plug (9).
18. Insert ball (13), stop (12), spring (11), and plug (9) in housing cavity 6. Torque plug (9) 47.5-54.2 Nm (35-40 lbft)
19. Insert new pin (22) in screw (21). Be sure pin is aligned properly and is evenly driven into screw. Do not damage the threads.
20. Install 1/4 inch diameter ball (18), retainer (19) and spring (20) into housing cavity 6.

continued on page 4.

● Items included in Repair Kit

* Not used in single accumulator charging valves

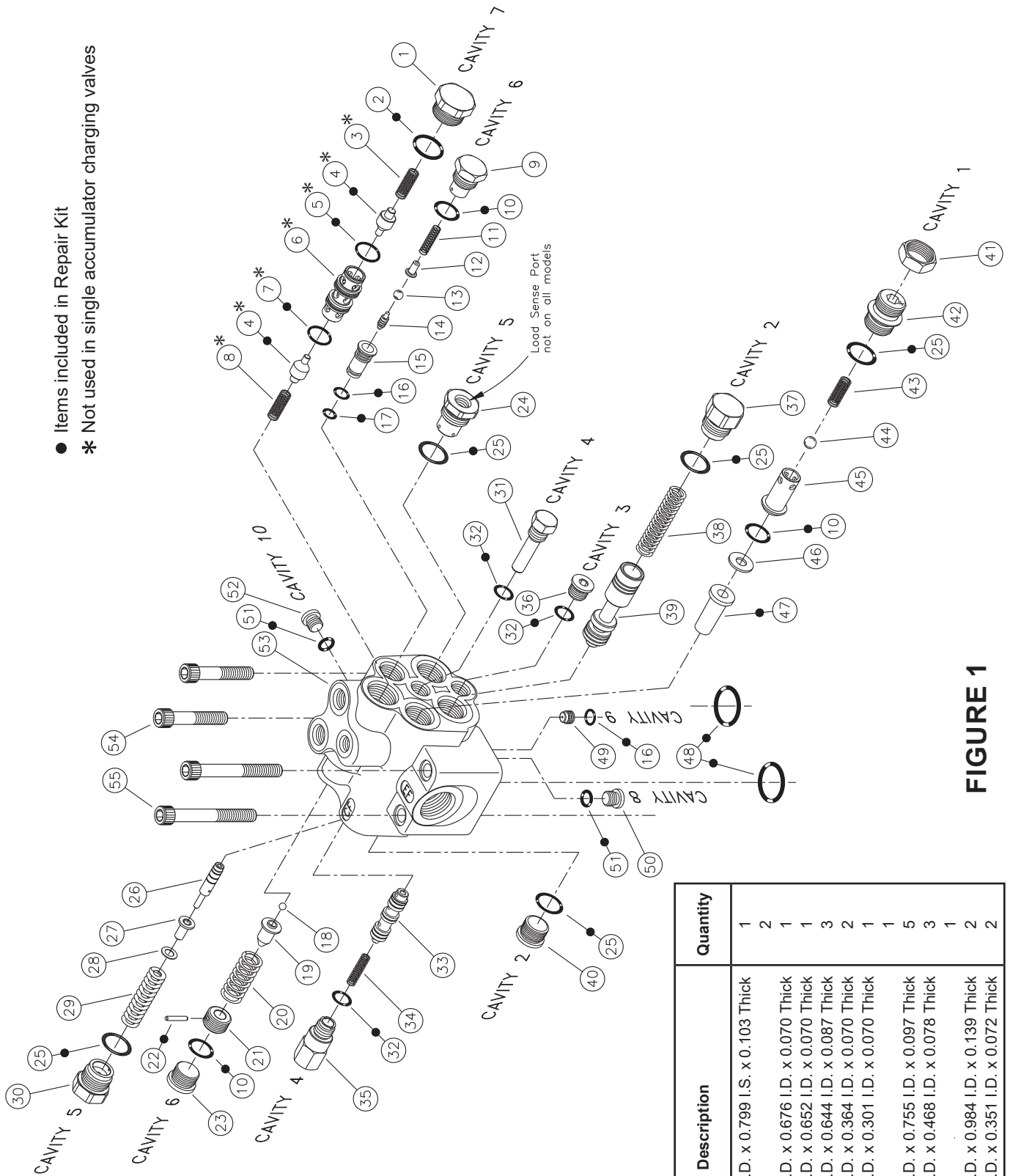

FIGURE 1

Item Number	Description	Quantity
2	O-ring 1.005 O.D. x 0.799 I.S. x 0.103 Thick	1
4	Poppet	2
5	O-ring 0.816 O.D. x 0.676 I.D. x 0.070 Thick	1
7	O-ring 0.792 O.D. x 0.652 I.D. x 0.070 Thick	1
10	O-ring 0.818 O.D. x 0.644 I.D. x 0.087 Thick	3
16	O-ring 0.504 O.D. x 0.364 I.D. x 0.070 Thick	2
17	O-ring 0.441 O.D. x 0.301 I.D. x 0.070 Thick	1
22	Plug	1
25	O-ring 0.949 O.D. x 0.755 I.D. x 0.097 Thick	5
32	O-ring 0.624 O.D. x 0.468 I.D. x 0.078 Thick	3
47	Filter	1
48	O-ring 1.262 O.D. x 0.984 I.D. x 0.139 Thick	2
51	O-ring 0.495 O.D. x 0.351 I.D. x 0.072 Thick	2

21. Thread screw (21) into cavity 6 TO THE DEPTH RECORDED during disassembly.
22. Install new o-ring (10) on plug (23). Install plug (23) into housing cavity 6 and torque 47.5-54.2 Nm (35-40 lbft)
23. Install new o-rings (5 & 7) on sleeve (6). **NOTE: Not all models use sleeve (6) or o-rings (5 & 7).**
24. Install spring (8), new poppets (4), sleeve (6), and spring (3) in housing cavity 7. **NOT: Not all models use spring (8), poppets (4), sleeve (6), or spring (3).**
25. Install new o-ring (2) on plug (1). Install plug (1) into housing cavity 7 and torque 67.8-81.4 Nm (50-60 lbft).
26. Install valve on machine using new o-rings (16 & 48) and cap screws (54 & 55).

CHARGE VALVE ADJUSTMENT

1. Properly reinstall the valve assembly. Connect the plumbing according to machine specifications.
2. To adjust accumulator charge limits, start the machine and wait 5-10 seconds for accumulator pressure to rise.
3. Adjust screw (21) with pump shut off to obtain specified pressure limits (Table 1). Clockwise adjustment increases pressure. Take a reading at the accumulator during this adjustment.

RELIEF VALVE ADJUSTMENT

1. Turn steering wheel until it bottoms.
2. Slowly turn steering wheel until steering pressure reaches specified pressure (Table 1). Take this reading at steering input line. Steering pressure should not exceed 210.3 bar (3000 PSI) during this adjustment.
3. Shut off pump and add or remove shim(s) (28) to obtain the correct pressure.