

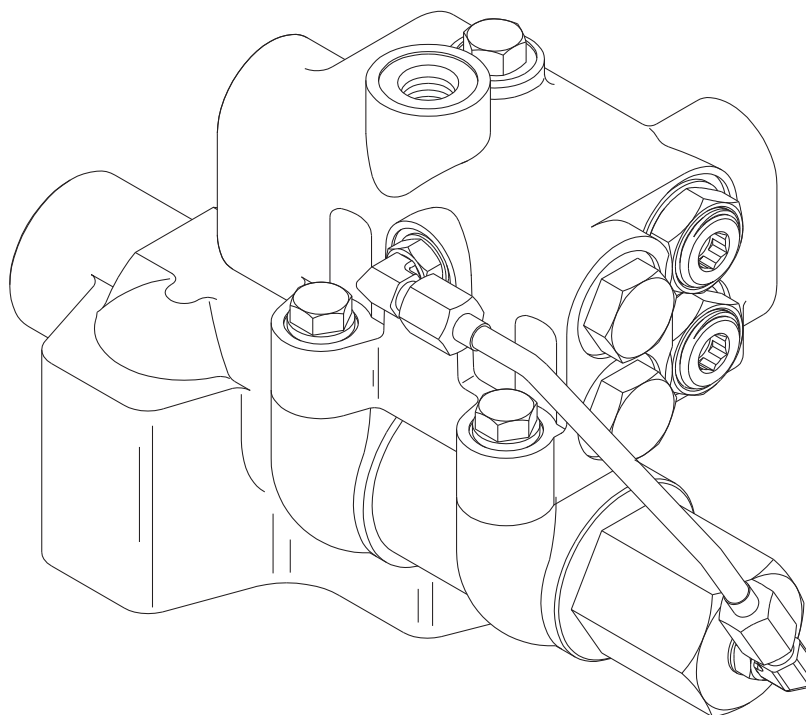

Dual Accumulator Charging Valve

Description and Operation



This publication is not subject to any update service. Information contained in this publication was in effect at the time the publication was approved for printing and is subject to change without notice or liability. ZF Off-Highway Solutions Minnesota Inc. reserves the right to revise the information presented or to discontinue the production of parts described at any time.



DESCRIPTION

(Refer to Figures 1, 2, and 3)

The Dual Accumulator Charging Valve is designed for installation in an open center hydraulic system. This valve is normally installed after the main pump/relief valve and before downstream secondary hydraulic devices, such as, a power steering valve, etc. (see Figure 1).

The Dual Accumulator Charging Valve is designed for use with mineral base hydraulic oil. Mineral base hydraulic oil and compatible wheel cylinder seals must be used.

The accumulator charging valve creates pressure used to charge the accumulators from an open center circuit, designed to operate within a preset range. When the accumulators are fully charged, it becomes a separate closed center circuit. The stored pressure in the accumulators provide available pressure for a brake control valve.

Flow through to the power steering valve or secondary devices is reduced fractionally for a very short time during accumulator charging. This does not noticeably

affect the operation of the power steering valve or secondary devices. Full system pressure is available to these devices at all times.

The energy stored in the accumulators permits full hydraulic power braking even when the open center hydraulic system is not functioning "power-off". The number of "power-off" brake applications is limited only by the amount of pressurized fluid stored in the accumulators and the volume required per application.

The accumulator charging rate, high pressure limit, and low pressure limit are preset at the factory to conform to specific customer requirements. Maximum available brake pressure is limited to prevent over-pressurizing the brake system.

This valve contains internal filters through which all oil in the charging valve, accumulators and brake system must flow. Hydraulic system cleanliness and adequate circuit filtration is imperative in any hydraulic system, minimum 10 micron filtration is recommended. All models currently available can also be modified for use with water glycol fluid when the application requires it.

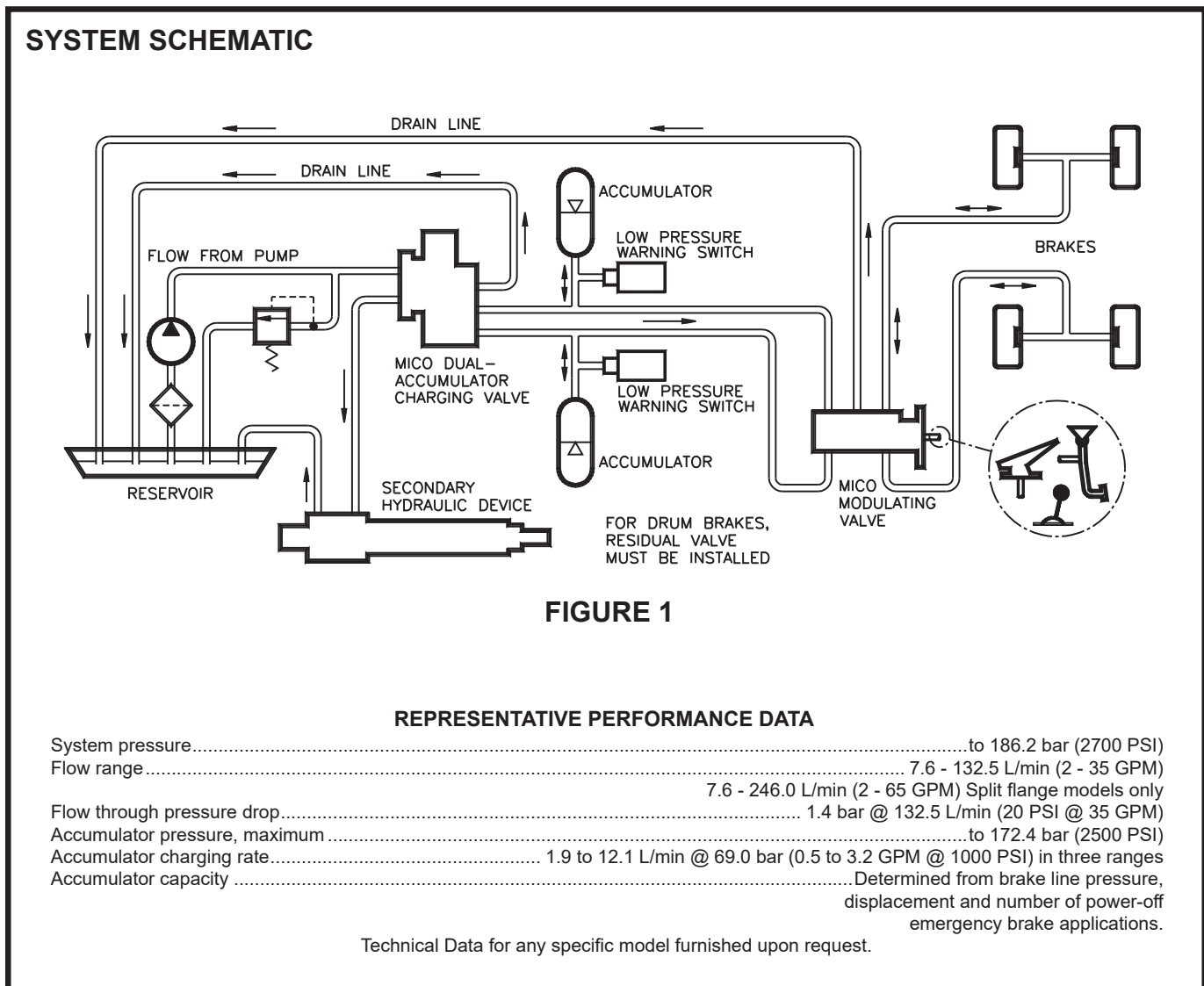

OPERATION

Charging Mode

(Refer to Figure 2)

The dual accumulator charging valve uses an internal spool valve to control hydraulic system flow to pressurize the accumulators.

At pump startup, force of spring (1) positions valve spool (2), causing flow restriction to the flow through port.

Fluid travels past the primary poppet check valves (3 & 4) to the accumulator ports. Pilot valve springs (5 & 6) hold low limit check balls (7 & 8) open and close high limit check balls (9 & 10). Pilot valve spools (11 & 12) only allows one of the check balls to be closed at a time. Flow to the accumulators also passes the open low limit check balls (7 & 8) and enters cavities (13 & 14). Simultaneously, pressure is building in cavity (15) and moving valve spool (2) toward stop (16), allowing hydraulic flow

to the flow through port. The position of valve spool (2) continues to change until the force of fluid pressure and spring force are balanced at both ends of valve spool (2). The force of spring (1) on valve spool (2) generates an increased pressure in cavity (15) assuring pump pressure is always higher than accumulator pressure. This guarantees priority of the charging function.

The rate at which the accumulators are charged depends on the size of the orifice in the check valve seats (17 & 18).

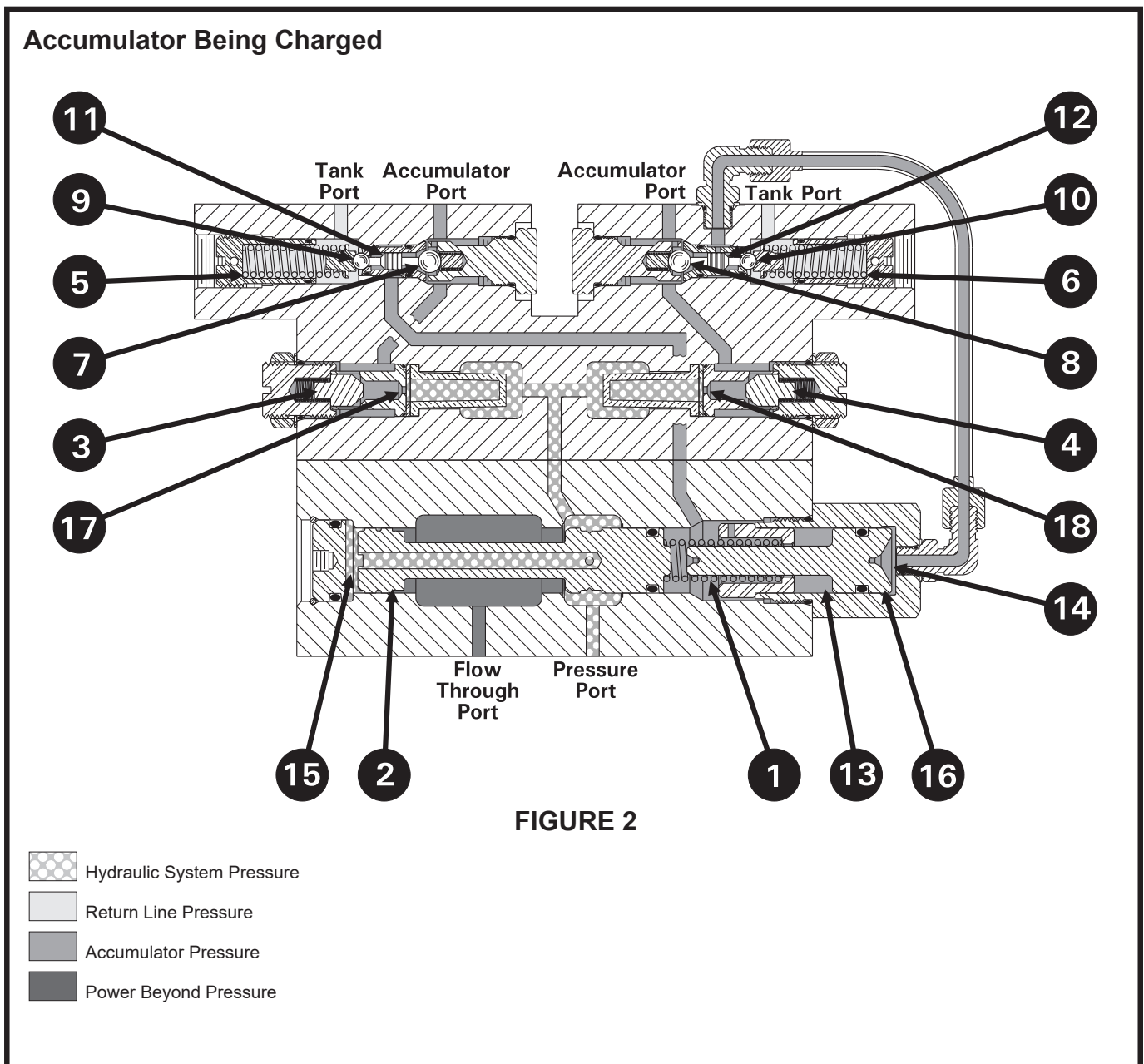

Standby Mode

(Refer to Figure 3)

When the accumulators pressure reaches the high charge limit, high limit check balls (9 & 10) open and the low limit check balls (7 & 8) close. With high limit check balls (9 & 10) open, pressure in cavities (13 & 14) is allowed to flow to tank port. Pressure in cavity (15) moves valve spool (2), allowing increased oil flow to be directed to the flow thru port. Primary poppet check valves (3 & 4) seat, holding accumulator pressure.

The charging valve is now in the standby mode, pump pressure responds to the force caused by spring (1) plus any downstream requirements.

The charging valve returns to the charging mode when accumulator pressure drops to a level where the force of spring (5) unseats low limit check ball (7) or spring (6) unseats low limit check ball (8).

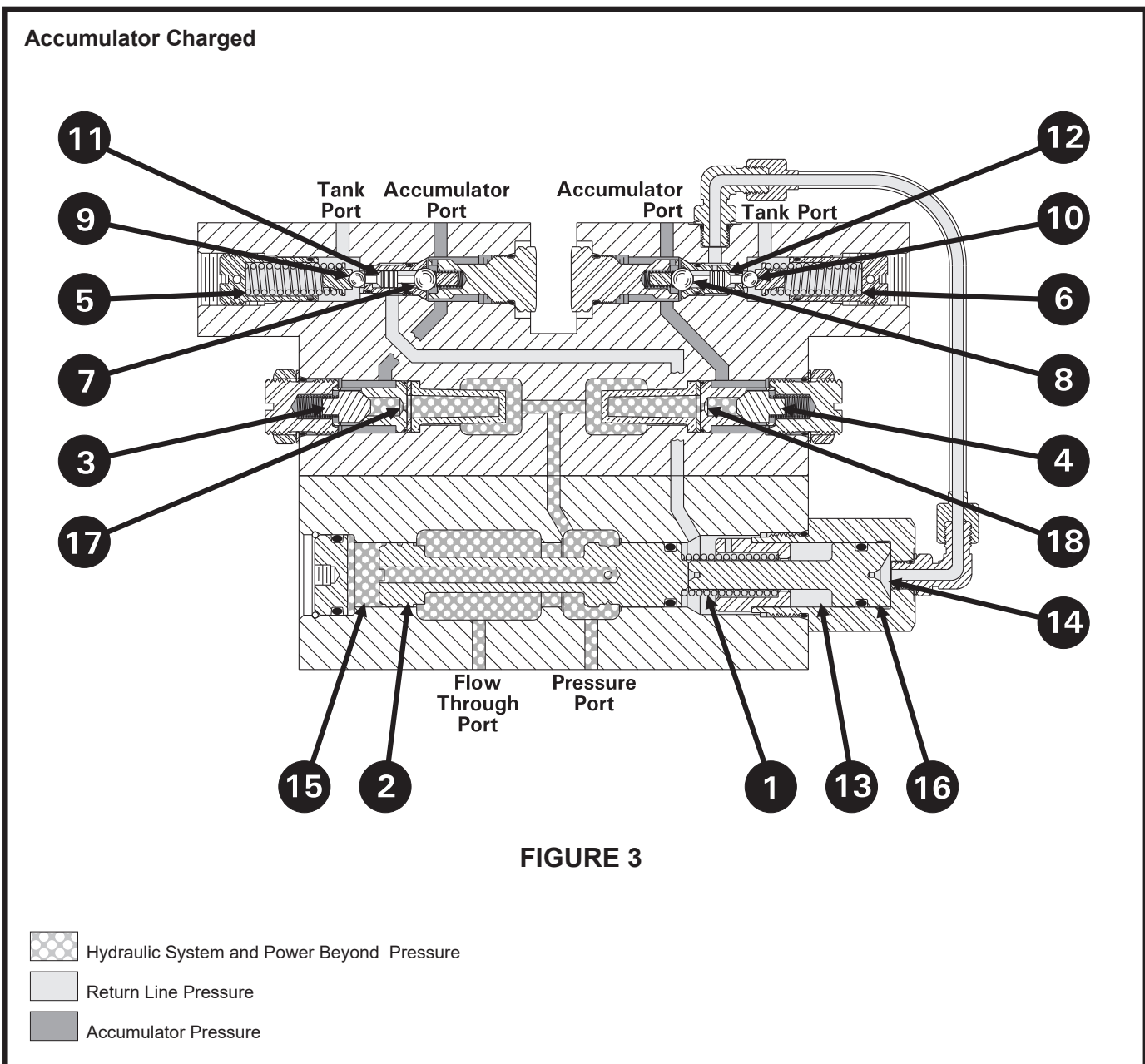
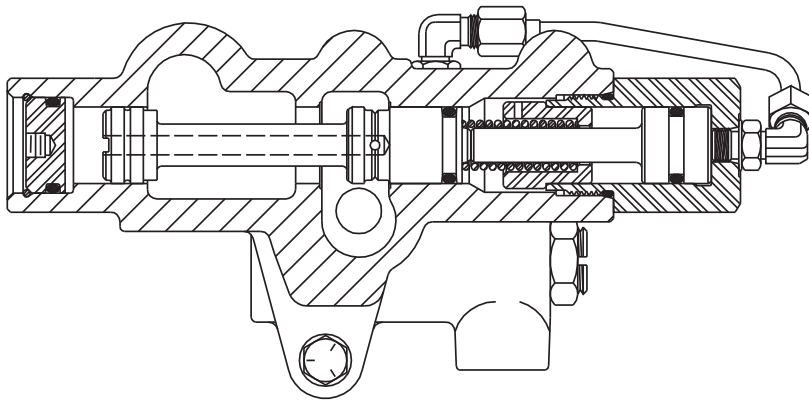
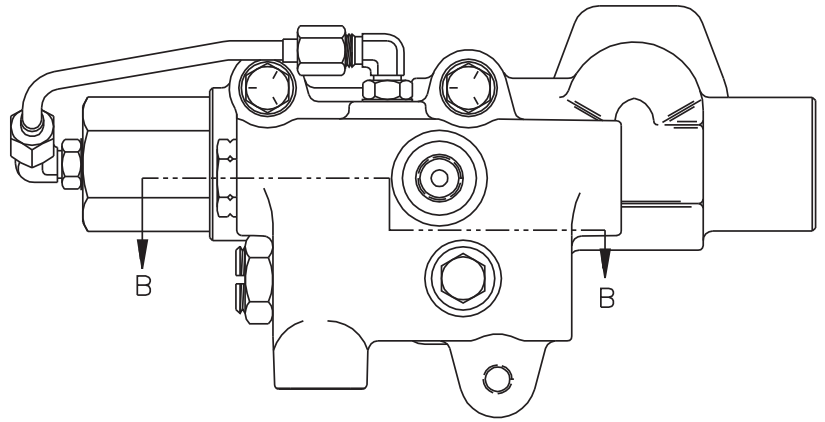
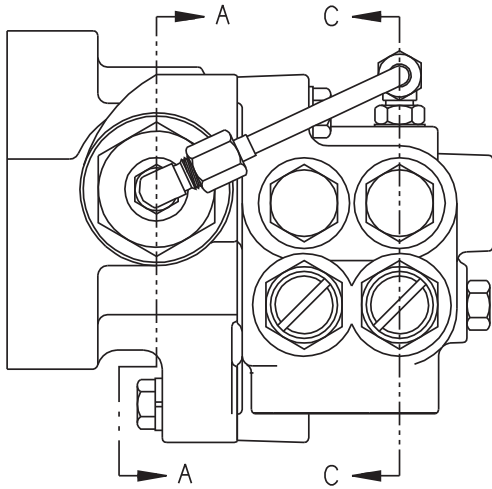

FIGURE 3

CROSS SECTION VIEWS - TYPICAL ACCUMULATOR CHARGING VALVE

NOTE: Valve shown with accumulator at high limit setting and brake pressure at maximum setting.



SECTION A-A

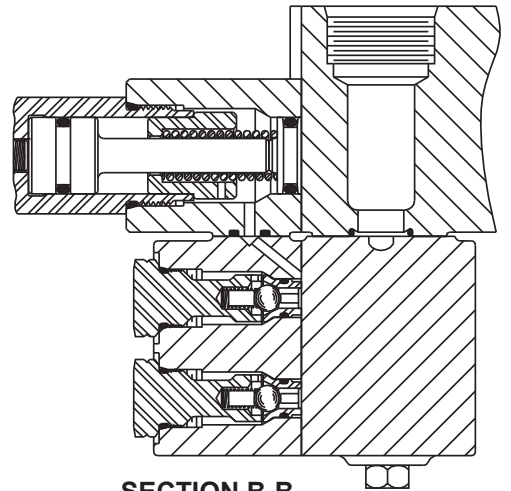

SECTION B-B

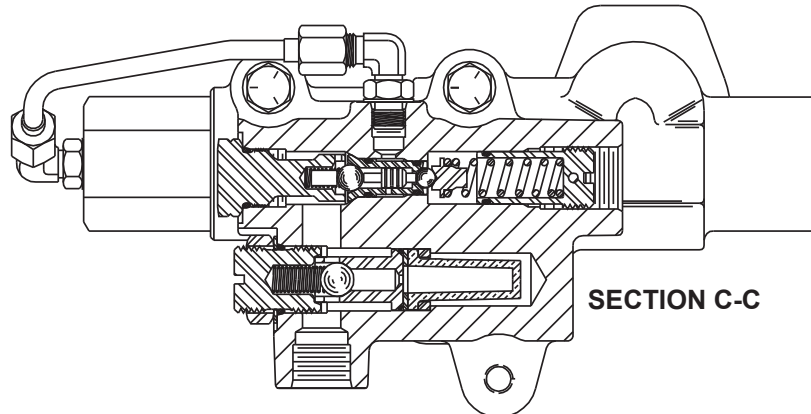

SECTION C-C

TYPICAL ACCUMULATOR CHARGING VALVE

(Dimensions will vary slightly between units and are to be used for reference purposes only).

