

BOOSTED MASTER CYLINDER (Power Assist Section)



Service Instructions

MASTER CYLINDER SECTION - Automotive Brake Fluid

POWER ASSIST SECTION - Mineral Base Hydraulic Oil

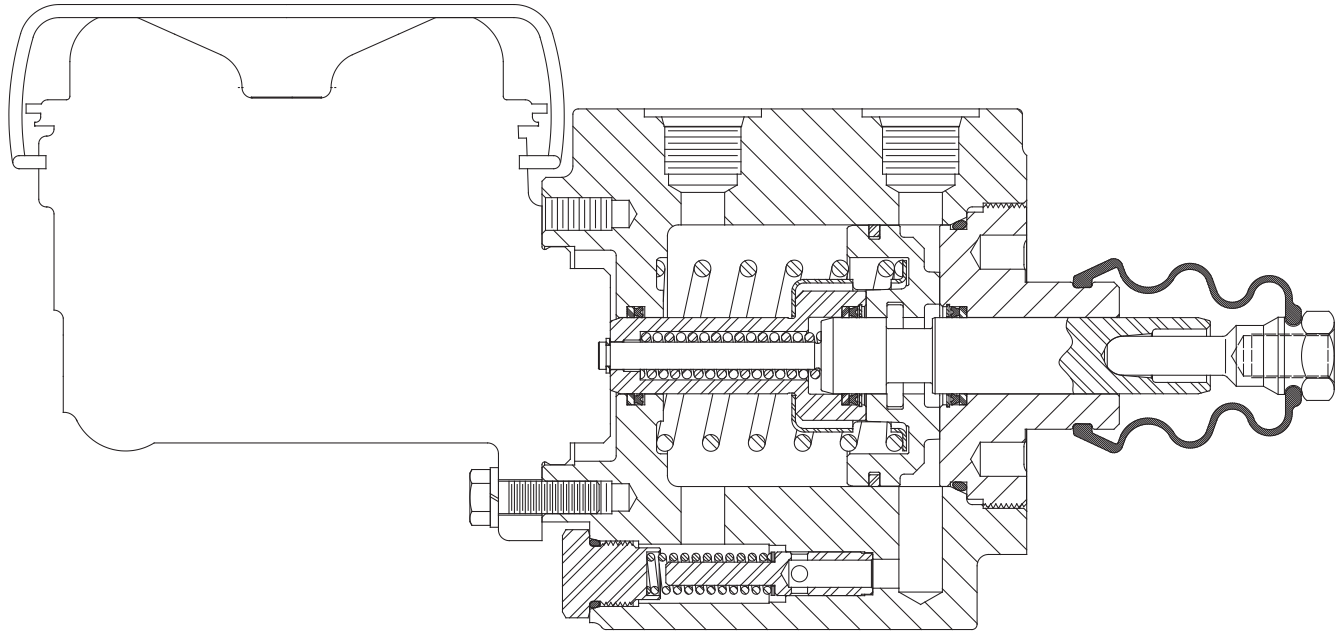
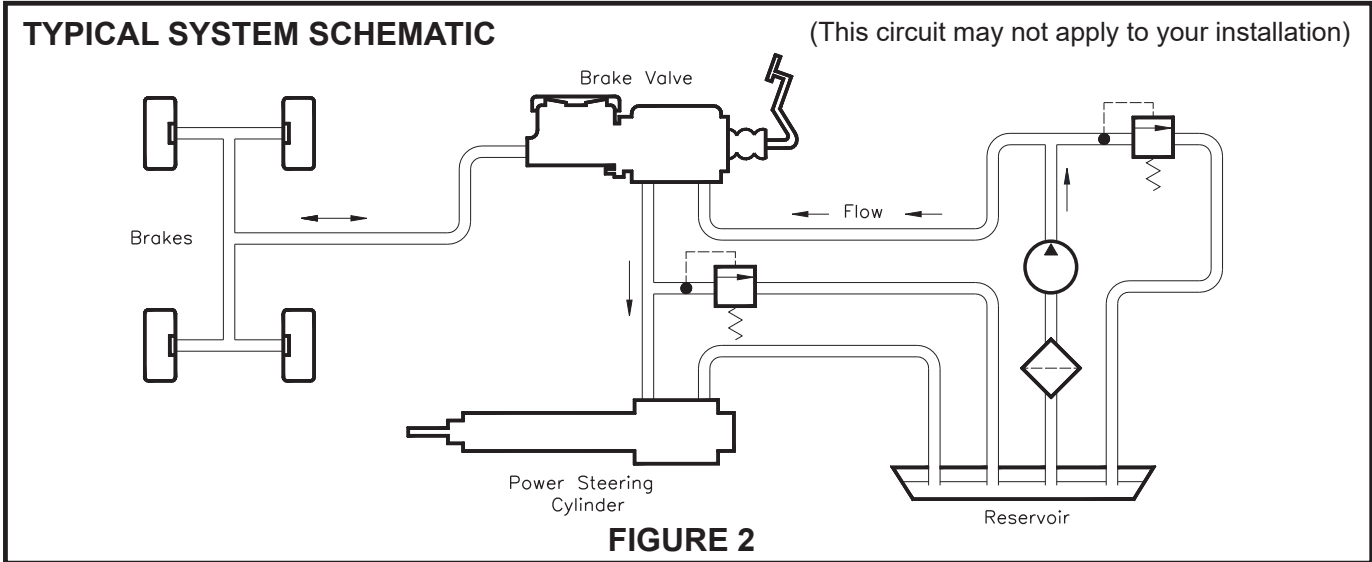

FIGURE 1

This instruction sheet services the Power Assist Section for this model number:

02-460-460

NOTE: If your product number is not listed, contact ZF Off-Highway Solutions Minnesota Inc. for information.



REMOVING MASTER CYLINDER FROM THE MACHINE AND SEPARATING SECTIONS

(Refer to Figures 1 and 3)

1. Remove the master cylinder assembly from the machine by disconnecting the necessary fluid lines, disconnecting the push rod, and removing the mounting bolts. Drain fluid from the assembly.
2. Separate the master cylinder section from the power assist section by removing three cap screws and three lock washers.

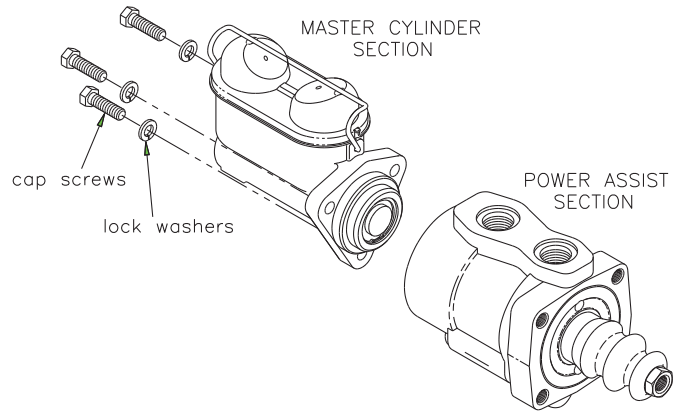

FIGURE 3

CONNECTING SECTIONS AND MOUNTING MASTER CYLINDER ON THE MACHINE

(Refer to Figures 1 and 3)

1. Attach the master cylinder section to the power assist section with three cap screws and three lock washers. Torque the cap screws 29.83-36.61 N·m (22-27 ft·lb).
2. Install the master cylinder assembly on the machine. Connect the push rod. Connect the fluid lines. Bleed the system of air. Tighten fittings if leaks occur. Make several applications to be sure the master cylinder is working properly. **NOTE: All fittings must be inspected for leaks and tightened if leaks occur.**

POWER ASSIST DISASSEMBLY

(Refer to Figures 1 and 4)

1. Drain fluid from the unit before disassembling.
2. Remove push rod (1) and boot (2) from the power assist section.
3. Loosen end plug (3) using a spanner wrench and remove internal parts assembly (19) from housing (20).
4. Remove spring (17) and retainer (16) from the internal parts assembly.
5. Remove end plug (3) from piston (8). Remove o-ring (4) from end plug (3). Remove retaining ring (7), cup (6) and back-up ring (5) from the bore of end plug (3). **NOTE: Be careful not to scratch the bore of end plug (3) when removing cup and back-up ring.**
6. Remove piston (10) from piston (8). Remove piston ring (9) from piston (10). **NOTE: Care must be taken when removing piston ring.**
7. Remove retaining ring (18) from piston (8).

⚠ CAUTION

Retaining ring (18) is under tension of spring (11).

8. Remove piston (15) from piston (8). Remove retaining ring (12), cup (13), and back-up ring (14) from bore of piston (15). **NOTE: Be careful not to scratch bore of piston (15) when removing cup and back-up ring.**
9. Remove spring (11) from piston (8).
10. Remove cup (21) and back-up ring (22) from housing (20). Note direction of cup (21). **NOTE: Be careful not to scratch housing bore when removing cup and back-up ring.**
11. Remove plug (27) from housing (20). Remove o-ring (26) from plug (27).
12. Remove spring (25), shims (24), and valve stem (23) from housing (20).

POWER ASSIST ASSEMBLY

(Refer to Figures 1 and 4)

Use only mineral base hydraulic oil in power assist section.

LUBRICATE ALL RUBBER COMPONENTS FROM THE REPAIR KIT WITH CLEAN TYPE FLUID USED IN THE SYSTEM.

1. Clean all parts thoroughly before assembling.
2. Install valve stem (23), shims (24) and spring (25) in housing. **NOTE: Valve stem (23) must move freely in housing (20).**
3. Install new o-ring (26) on plug (27) and install in housing (20).
4. Install new cup (21) and new back-up ring (22) in housing (20). Note direction of cup (21).
5. Install new back-up ring (5), new cup (6), and new retaining ring (7) in end plug (3). Note direction of cup (6).
6. Install new spring (11) on piston (8).
7. Install new back-up ring (14), new cup (13), and new retaining ring (12) in piston (15). **NOTE: Be careful not to scratch or mar piston bore.**
8. Install piston (15) over spring (11) and piston (8).
9. Install new retaining ring (18) on piston (8).
10. Install new piston ring (9) on piston (10). **NOTE: Be careful when installing piston ring.**
11. Install piston (10) on piston (8). Note direction of piston (10).
12. Install new o-ring (4) on end plug (3).
13. Install end plug (3) over piston (8).
14. Install retainer (16) over piston (15) and install new spring (17) over retainer (16).
15. Install internal parts assembly (19) into housing bore. Use a spanner wrench to torque end plug (3) 40.68-54.24 N·m (30-40 lb·ft).
16. Install new boot (2) on end plug (3) and install push rod (1) onto boot (2).

● Items included in Repair Kit 02-400-233

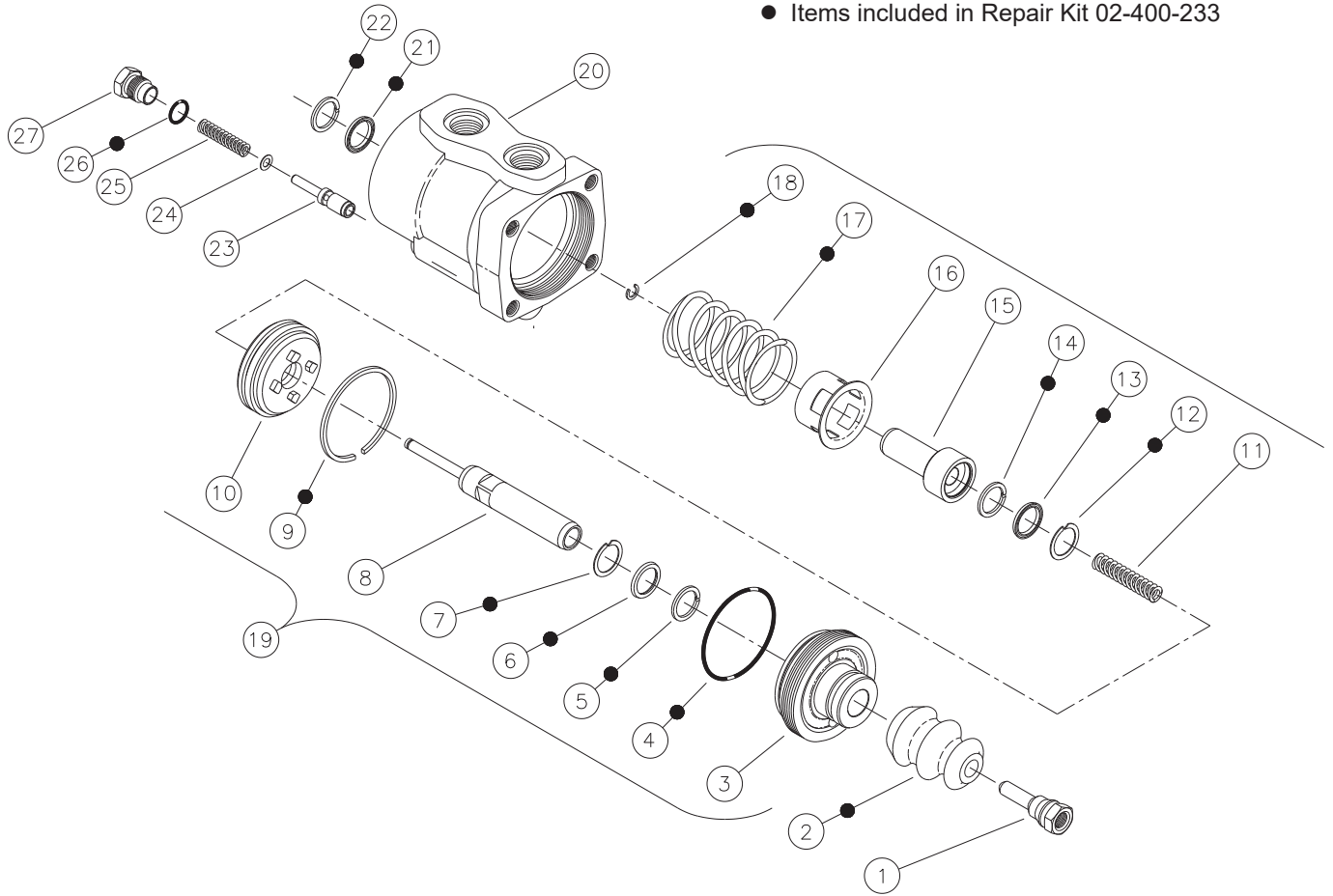

FIGURE 4

BLEEDING PROCEDURES

NOTE

Use only proper fluid specified by machine manufacture. Never reuse fluid that has been drained from the system. Be sure that you maintain a high level of fluid in the reservoir during and after the entire bleeding process.

PRESSURE BLEEDING INSTRUCTIONS

1. Master cylinder must be mounted to the power assist section.
2. Fill the reservoir with proper fluid.
3. Be sure all fittings are tight to avoid leaking.
4. DO NOT DEPRESS THE PEDAL.
5. Connect a pressure bleeder to the reservoir adapter. Recommended bleeding pressure is 2.07 bar (30 PSI) maximum. **NOTE: Make sure to use correct pressure bleeder for the type fluid used in the system.**
6. Open the bleeder screw closest to the master cylinder outlet. Most of the air contained in the system will escape through this route. Close the bleeder screw.
7. Continue to the next bleeder screw and so on. At each point when air bubbles disappear close the bleeder screw.
8. Remove the pressure bleeder.
9. Open the bleeder screw at the master cylinder. Actuate the cylinder to remove any residual air. Tighten bleeder screw before allowing the pedal to return.
10. Depress the pedal several times. If the pedal is spongy, check for system leaks and repeat bleeding process.
11. Fill the reservoir to within 12.7 mm (0.50 in) of top. Install filler cap and torque 33.9-40.7 N·m (25-30 lb·ft).

BENCH BLEEDING INSTRUCTIONS

(Refer to Figure 5)

1. This process can be done in a bench vise or on the machine with master cylinder mounted to power assist section.
2. Remove master cylinder filler cap.
3. Connect a length of tubing to an outlet port and immerse the other bend below the fluid level in the master cylinder reservoir. Keep reservoir fluid within 12.7 mm (0.50 in) of inside reservoir top.
4. Actuate master cylinder piston with a smooth object large enough to hold the small internal piston from coming out. Slowly stroke and release master cylinder piston. **See CAUTION below.** Repeat until air bubbles in reservoir have ceased.
5. Remove the tubing. This should be done quickly so the loss of fluid will be minimized.
6. If the master cylinder was bench bled in a vise, it must now be attached securely to the power assist section and mounted on machine. Complete all plumbing connections before continuing to step 7.
7. Bleed remaining air from system by depressing brake pedal and opening bleeder fitting closest to the master cylinder. Close the bleeder fitting

before brake pedal is released.

Continue to next bleeder port. In all cases the bleeder fittings must be closed before the brake pedal is released or air will be pulled in through the bleeder and ingest unwanted air in the system.

8. Fill the reservoir to within 12.7 mm (0.50 in) of top. Install filler plug and torque 33.9-40.7 N·m (25-35 lb·ft).
9. Be certain all fittings are tight to avoid any leaking.
10. Depress the pedal several times. If brake pedal feels spongy, check for system leaks and repeat the bleeding process.

CAUTION

Care must be taken so as not to over stroke this cylinder. The cylinder does not incorporate a piston stop. Over stroking this cylinder may cause it to leak from push rod end of cylinder. Maximum recommended stroke for this cylinder is 31.8 mm (1.25 in).

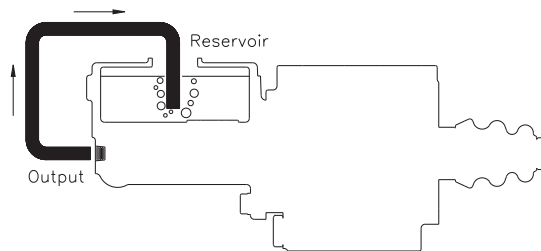

FIGURE 5

This publication is not subject to any update service. Information contained in this publication was in effect at the time the publication was approved for printing and is subject to change without notice or liability. ZF Off-Highway Solutions Minnesota Inc. reserves the right to revise the information presented or to discontinue the production of parts described at any time.



ZF Off-Highway Solutions Minnesota Inc.

1911 Lee Boulevard / North Mankato, MN U.S.A. 56003

Tel: +1 507 625 6426 Fax: +1 507 625 3212