

BOOSTED MASTER CYLINDER (Master Cylinder Section)



Service Instructions

MASTER CYLINDER SECTION - Automotive Brake Fluid

POWER ASSIST SECTION - Mineral Base Hydraulic Oil

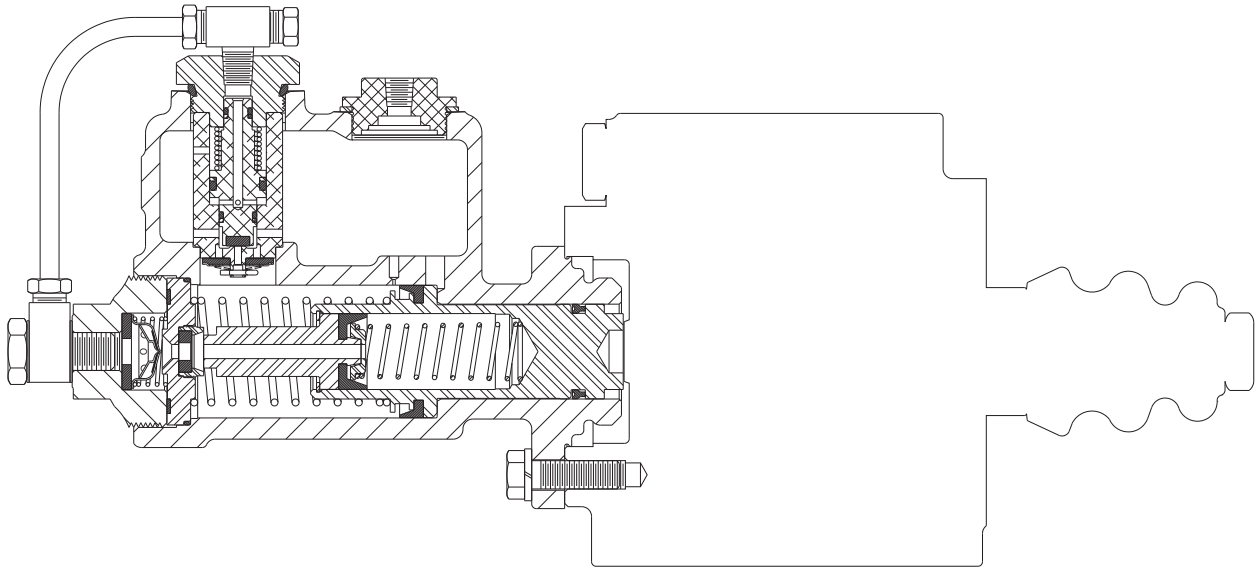

FIGURE 1
(02-460-450 Shown)

This instruction sheet services the Master Cylinder Section for these model numbers:

02-460-450

02-460-452

NOTE: If your product number is not listed, contact ZF Off-Highway Solutions Minnesota Inc. for information.

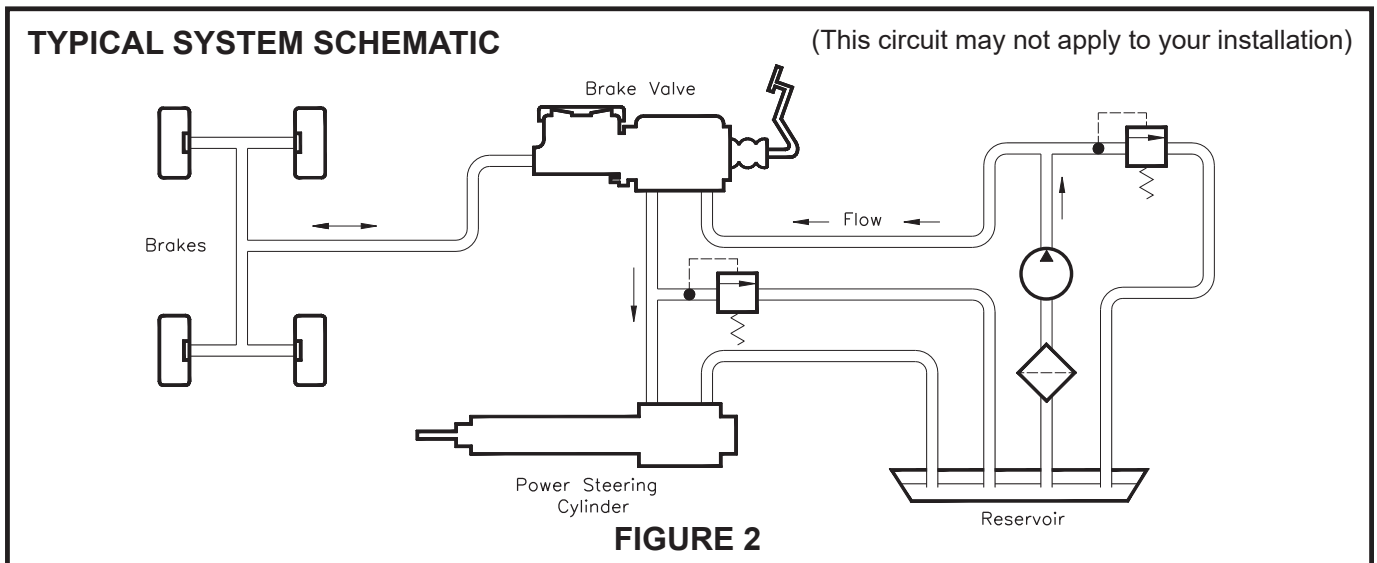

REMOVING MASTER CYLINDER FROM THE MACHINE AND SEPARATING SECTIONS

(Refer to Figures 1 and 3)

1. Remove the master cylinder assembly from the machine by disconnecting the necessary fluid lines, disconnecting the push rod, and removing the mounting bolts. Drain the fluid from the assembly.
2. Separate the master cylinder section from the power assist section by removing three cap screws and three lock washers.

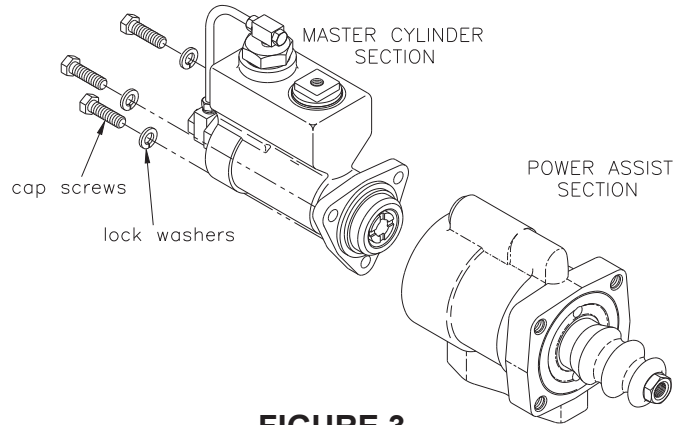

CONNECTING SECTIONS AND MOUNTING MASTER CYLINDER ON THE MACHINE

(Refer to Figures 1 and 3)

1. Attach the master cylinder section to the power assist section with three cap screws and three lock washers. Torque cap screws 29.8-36.6 N·m (22-27 lb·ft).
2. Install the master cylinder assembly on the machine. Connect the push rod. Connect the fluid lines. Fill the reservoir and bleed the system of air.

FIGURE 3

Tighten fittings if leaks occur. Make several applications to be sure the master cylinder is working properly.

NOTE: All fittings must be inspected for leaks and tightened if leaks occur.

DISASSEMBLY

(Refer to Figures 1 and 4)

1. Drain fluid from the unit before disassembling.
2. Remove upper tube nut on tubing assembly (27) from fitting (26).
3. Remove line bolt (1), gaskets (2 & 4), and fitting block (3). Tubing assembly (27) need not be removed from fitting block (3).
4. Remove end plug (5) using a large box end wrench.

⚠ CAUTION

End plug (5) is under tension of spring (12).

5. Remove spring (8), check valve (7), and seat (6) from end plug (5).
6. Retainer assembly (10) should follow end plug (5) as it is removed. Remove o-ring (11) from housing (22).
7. Remove spring (12) from housing (22).
8. Use a wooden dowel to push piston assembly (21) out of the large bore side of housing (22).
9. Remove cups (18 & 20) from piston (19).
10. Depress piston (14) and remove retaining ring (13). Hold firmly, spring (17) will force piston (14) out of piston (19) bore. Remove cup (15) from piston (14).
11. Remove retainer (16) and spring (17).
12. Remove fitting (26) from relief valve assembly (25).
13. Remove relief valve assembly (25) from housing (22).
14. Remove filler cap (24) and gasket (23) from housing (22).

ASSEMBLY

(Refer to Figures 1 and 4)

Use only automotive brake fluid in the master cylinder section.

LUBRICATE ALL RUBBER COMPONENTS FROM THE REPAIR KIT WITH CLEAN TYPE FLUID USED IN THE SYSTEM.

1. Clean all parts thoroughly before assembling.
2. Install new retainer (16) on end of spring (17). Install spring, large end first, into piston (19).
NOTE: Retainer (16) removed from your cylinder may appear different than retainer (16) in Figure 4, replace with new retainer provided in repair kit.
3. Install new cup (15) on piston (14).
4. Insert piston (14) into piston (19) with cup (15) against retainer (16). Depress piston (14) and install new retaining ring (13).
5. Install new cup (18) and new cup (20) on piston (19). Note direction of cups (18 & 20).
6. Install piston assembly (21) into housing (22). Note direction of piston assembly (21).
7. Install spring (12) over piston assembly (21).
8. Install new o-ring (11) in housing (22) and new seal (9) on new retainer assembly (10). Install new retainer assembly (10) into housing (22). Note direction of retainer assembly (10).
9. Assemble new seat (6), new check valve (7), and spring (8) between retainer assembly (10) and end plug (5).
10. Install end plug (5) into housing (22). Use a large box end and torque end plug (5) 67.8-108.5 N·m (50-80 lb·ft).
11. Install new relief valve assembly (25) into housing (22) and torque 88.1-101.7 N·m (65-75 lb·ft).
12. Install fitting (26) into new relief valve assembly (25) and tighten.
13. Assemble new gaskets (2 & 4), fitting block (3), and line bolt (1) into end plug (5). Torque line bolt (1) 47.5-61.0 N·m (35-45 lb·ft). **NOTE: Hold fitting block (3) in a fixed position as shown in Figure 4 while tightening line bolt (1).**

- Items included in Repair Kit
- * Not used on all models

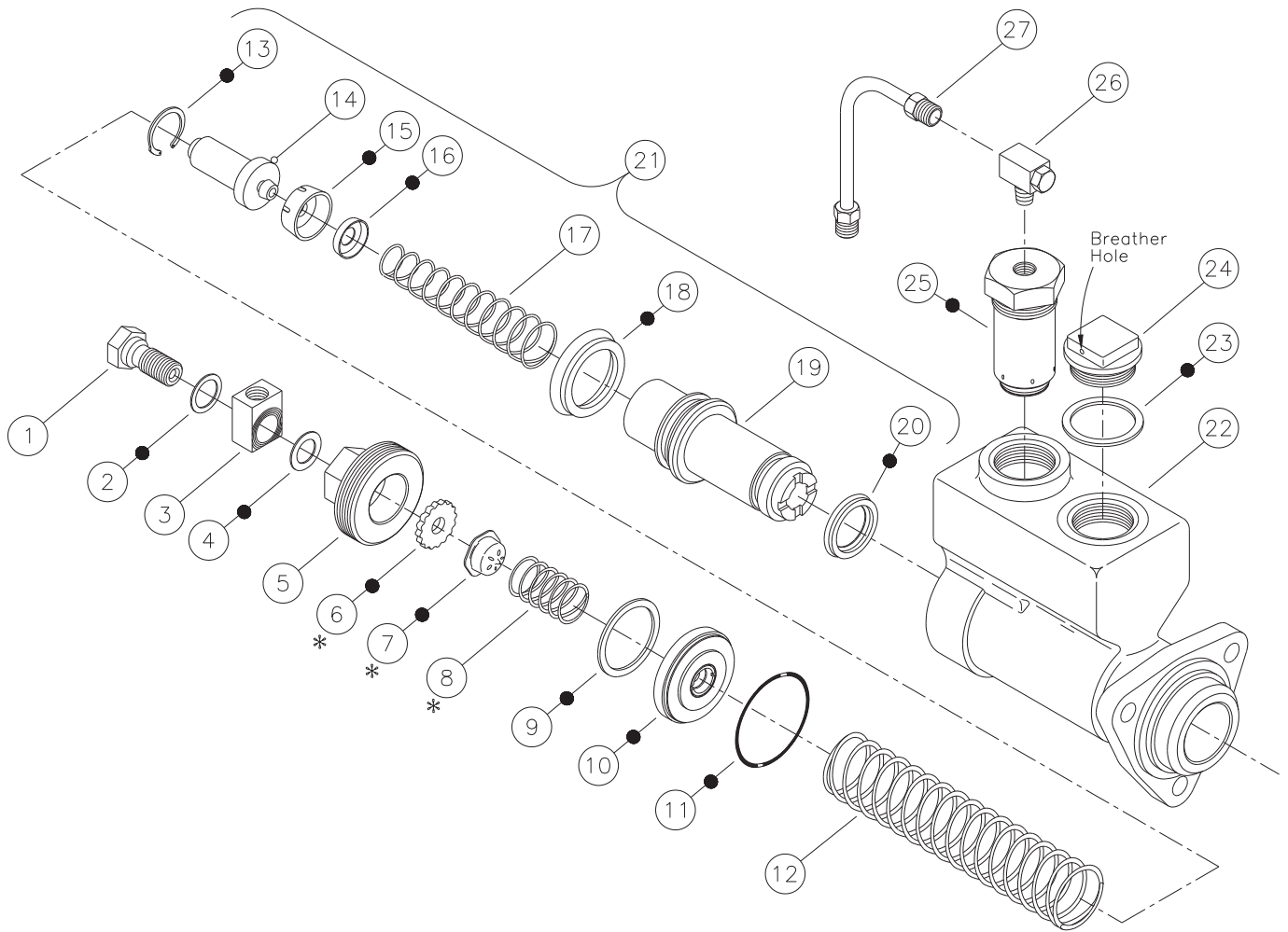

FIGURE 4

14. Install upper tube nut on tubing assembly (27) into fitting (26). Torque upper and lower tube nuts 12.2-20.3 N·m (9-15 lb·ft).
15. **NOTE: If your filler cap (24) has a breather hole as shown in Figure 4, before installing filler cap (24) be sure the filler cap breather hole is free of all contaminants. Use air pressure to clean and dry this hole.** Install new gasket (23) and filler cap (24) on housing (22).

BLEEDING PROCEDURES

NOTE

Use only proper fluid specified by the machine manufacture. Never reuse fluid that has been drained from the system. Be sure that you maintain a high level of fluid in the reservoir during and after the entire bleeding process.

PRESSURE BLEEDING INSTRUCTIONS

1. Master cylinder must be mounted to the power assist section.
2. Fill the reservoir with proper fluid.
3. Be certain all fittings are tight to avoid leaking.
4. DO NOT DEPRESS THE PEDAL.
5. Connect pressure the bleeder to the reservoir adapter. Recommended bleeding pressure is 2.07 bar (30 PSI) maximum. **NOTE: Make sure to use the correct pressure bleeder for the type fluid used in the system.**
6. Open the bleeder screw closest to the master cylinder outlet. Most of the air contained in the system will escape by this route. Close the bleeder screw.
7. Continue to the next bleeder screw and so on. At each point when air bubbles disappear close the bleeder screw.
8. Remove the pressure bleeder.
9. Open the bleeder screw at the master cylinder. Actuate the master cylinder to remove any residual air. Tighten the bleeder screw before allowing the pedal to return.
10. Depress the pedal several times. If the pedal is spongy, check for system leaks and repeat bleeding process.
11. Fill the reservoir to within 12.7 mm (0.50 in) of the top. Install the filler cap and torque 33.9-40.7 N·m (25-30 lb·ft).

BENCH BLEEDING INSTRUCTIONS

(Refer to Figure 5)

1. This process can be done in a bench vise or on the machine with master cylinder mounted to power assist section.
2. Remove the master cylinder filler cap.
3. Connect a length of tubing to an outlet port and immerse the other end below the fluid level in the master cylinder reservoir. Keep the reservoir fluid within 12.7 mm (0.50 in) of inside reservoir top.
4. Actuate master cylinder piston with a smooth object large enough to hold the small internal piston from coming out. Slowly stroke and release master cylinder piston. See CAUTION below. Repeat until air bubbles in reservoir have ceased.
5. Remove the tubing. This should be done quickly so the loss of fluid will be minimized.
6. If the master cylinder was bench bled in a vise, it must now be attached securely to the power assist section and mounted on machine. Complete all plumbing connections before continuing to step 7.
7. Bleed remaining air from the system by depressing the brake pedal and opening the bleeder screw closest to the master cylinder. Close the bleeder screw before the brake pedal

- is released. Continue to the next bleeder port. In all cases the bleeder screw must be closed before the brake pedal is released or air will be pulled in through the bleeder and ingest unwanted air in the system.
8. Fill the reservoir to within 12.7 mm (0.50 in) of the top. Install filler cap and torque 33.9-40.7 N·m (25-30 lb·ft).
9. Be sure all fittings are tight to avoid any leaking.
10. Depress the pedal several times. If the brake pedal feels spongy, check for system leaks and repeat the bleeding process.

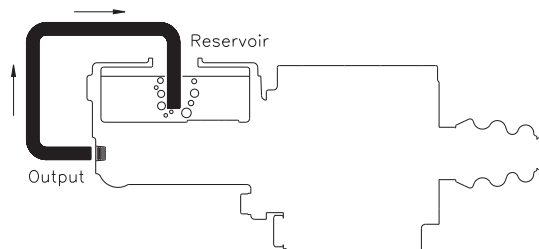

FIGURE 5

This publication is not subject to any update service. Information contained in this publication was in effect at the time the publication was approved for printing and is subject to change without notice or liability. ZF Off-Highway Solutions Minnesota Inc. reserves the right to revise the information presented or to discontinue the production of parts described at any time.

