

BOOSTED MASTER CYLINDER (Master Cylinder Section)



Service Instructions

MASTER CYLINDER SECTION - Automotive Brake Fluid

POWER ASSIST SECTION - Mineral Base Hydraulic Oil

REMOVING MASTER CYLINDER FROM THE MACHINE AND SEPARATING SECTIONS

(Refer to Figure 1)

1. Remove the master cylinder from the machine by disconnecting the necessary fluid lines, disconnecting the push rod, and removing the mounting bolts. Drain fluid from the assembly.
2. Separate master cylinder section from power assist section by removing three cap screws and three lock washers.

CONNECTING SECTIONS AND MOUNTING MASTER CYLINDER ON MACHINE

(Refer to Figure 1)

1. Attach the master cylinder section to the power assist section using three cap screws and three lock washers. Torque 29.83-36.61 N·m (22-27 lb-ft)
 2. Install unit on machine. Connect push rod. Connect fluid lines. Fill reservoir and bleed system of air. Tighten fittings if leaks occur. Make several applications to be sure brake valve is working properly.
- NOTE: All fittings must be inspected for leaks and tightened if leaks occur.**

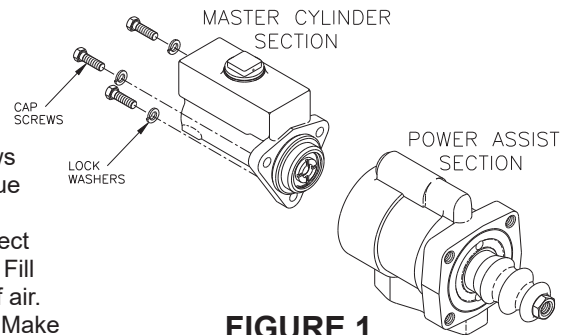

FIGURE 1

DISASSEMBLY

(Refer to Figure 2)

1. Drain fluid from unit before disassembling.
2. Remove retaining ring (1) from housing (8). **NOTE: Retaining ring is under tension of spring (5).**
3. Remove piston assembly (2) from housing (8) bore.
4. Remove cup (3), retainer (4), spring (5), check valve (6), and seat (7) from housing (8). **NOTE: Not all models use check valve (6) and seat (7).**
5. Remove filler cap (10) and gasket (9) from housing (8).

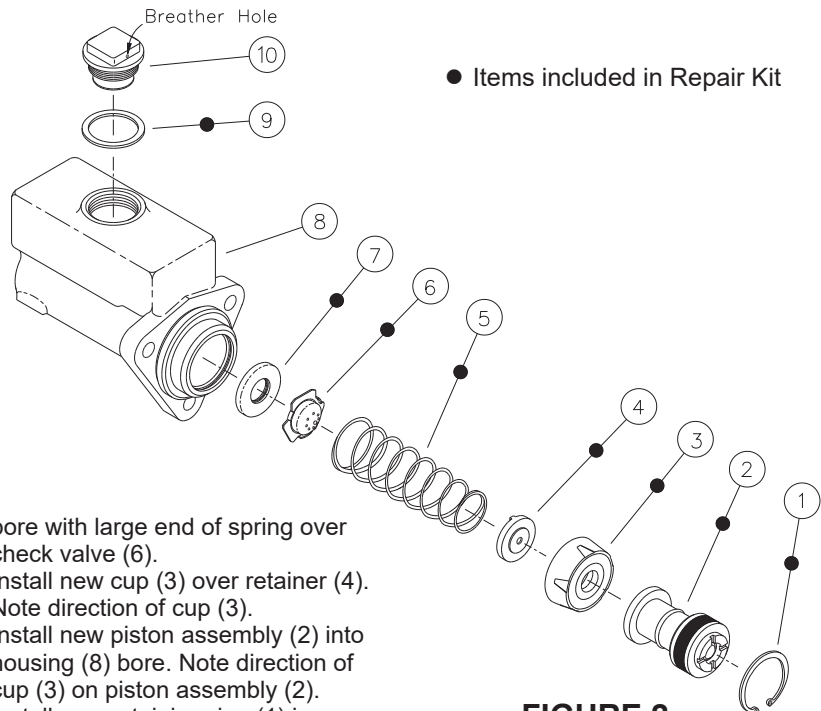

FIGURE 2

ASSEMBLY

(Refer to Figure 2)

Use only automotive brake fluid in master cylinder section.

LUBRICATE ALL RUBBER COMPONENTS FROM THE REPAIR KIT WITH CLEAN TYPE FLUID USED IN THE SYSTEM.

1. Clean all parts thoroughly before assembling.
2. Install new seat (7) and new check valve (6) in bore of housing (8). **NOTE: Install new check valve (6) and new seat (7) only if originally used in your master cylinder.**
3. Attach new retainer (4) to the small end of new spring (5). Install assembly (4 & 5) into housing

- bore with large end of spring over check valve (6).
4. Install new cup (3) over retainer (4). Note direction of cup (3).
 5. Install new piston assembly (2) into housing (8) bore. Note direction of cup (3) on piston assembly (2).
 6. Install new retaining ring (1) in housing (8).
 7. **NOTE: Before installing filler plug (10) be sure filler plug (10) breather hole is free of all contaminants. Use air pressure to clean and dry this hole.** Install new gasket (9) and filler cap (10) on housing (8).

BLEEDING PROCEDURES

NOTE

Use only proper fluid specified by machine manufacture. Never reuse fluid that has been drained from the system. Be sure that you maintain a high level of fluid in the reservoir during and after the entire bleeding process.

PRESSURE BLEEDING INSTRUCTIONS

1. The master cylinder must be mounted to the power assist section.
2. Fill reservoir with proper fluid.
3. Be sure all fittings are tight to avoid leaking.
4. DO NOT DEPRESS PEDAL.
5. Connect the pressure bleeder to the reservoir adapter. Recommended bleeding pressure is 2.07 bar (30 PSI) maximum. **NOTE: Be sure to use correct pressure bleeder for type of fluid used in system.**
6. Open the bleeder screw closest to the master cylinder outlet. Most of the air contained in the system will escape by this route. Close bleeder screw.
7. Continue to the next bleeder screw and so on. At each point when air bubbles disappear close the bleeder screw.
8. Remove the pressure bleeder.
9. Open the bleeder screw at the master cylinder. Actuate the master cylinder to remove any residual air. Tighten bleeder screw before allowing the pedal to return.
10. Depress the pedal several times. If the pedal is spongy, check for system leaks and repeat bleeding process.
11. Fill the reservoir to within 12.7 mm (0.50 in) of the top. Install filler cap and torque 33.9-47.5 N·m (25-35 lb-ft).

BENCH BLEEDING INSTRUCTIONS

(Refer to Figure 3)

1. This process can be done in a bench vise or on the machine with master cylinder mounted to power assist section.
2. Remove master cylinder filler cap.
3. Connect a length of tubing to an outlet port and immerse the other end below the fluid level in the master cylinder reservoir. Keep the reservoir fluid filled to within 12.7 mm (0.50 in) of the inside reservoir top.
4. Actuate master cylinder piston with a smooth object large enough to hold the small internal piston from coming out. Slowly stroke and release master cylinder piston. **See CAUTION below.** Repeat until air bubbles in reservoir have ceased.
5. Remove tubing. This should be done quickly so the loss of fluid will be minimized.
6. If the master cylinder was bench bled in a vise, it must now be attached securely to the power assist section and mounted on the machine. Complete all plumbing connections before continuing to step 7.
7. Bleed remaining air from system by depressing brake pedal and opening the bleeder screw closest to master cylinder. Close bleeder screw before

brake pedal is released. Continue to next bleeder port. In all cases the bleeder screws must be closed before the brake pedal is released or air will be pulled in through the bleeder and ingest unwanted air in the system.

8. Fill reservoir to within 12.7 mm (0.50 in) of top. Install filler cap and torque 33.9-47.5 N·m (25-35 lb-ft).
9. Be sure all fittings are tight to avoid any leaking.
10. Depress the pedal several times. If the brake pedal feels spongy, check for system leaks and repeat the bleeding process.

CAUTION

Be careful not to over stroke this cylinder. It does not incorporate a piston stop. Over stroking this cylinder may cause it to leak from the push rod end of the cylinder. Maximum recommended stroke for this cylinder is 31.8 mm (1.25 in).

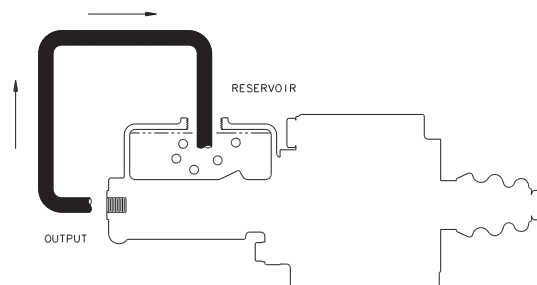

FIGURE 3

This publication is not subject to any update service. Information contained in this publication was in effect at the time the publication was approved for printing and is subject to change without notice or liability. ZF Off-Highway Solutions Minnesota Inc. reserves the right to revise the information presented or to discontinue the production of parts described at any time.



ZF Off-Highway Solutions Minnesota Inc.

1911 Lee Boulevard / North Mankato, MN U.S.A. 56003

Tel: +1 507 625 6426 Fax: +1 507 625 3212