

# BOOSTED MASTER CYLINDER (Master Cylinder Section)



## Service Instructions

MASTER CYLINDER SECTION - Automotive Brake Fluid

POWER ASSIST SECTION - Mineral Base Hydraulic Oil

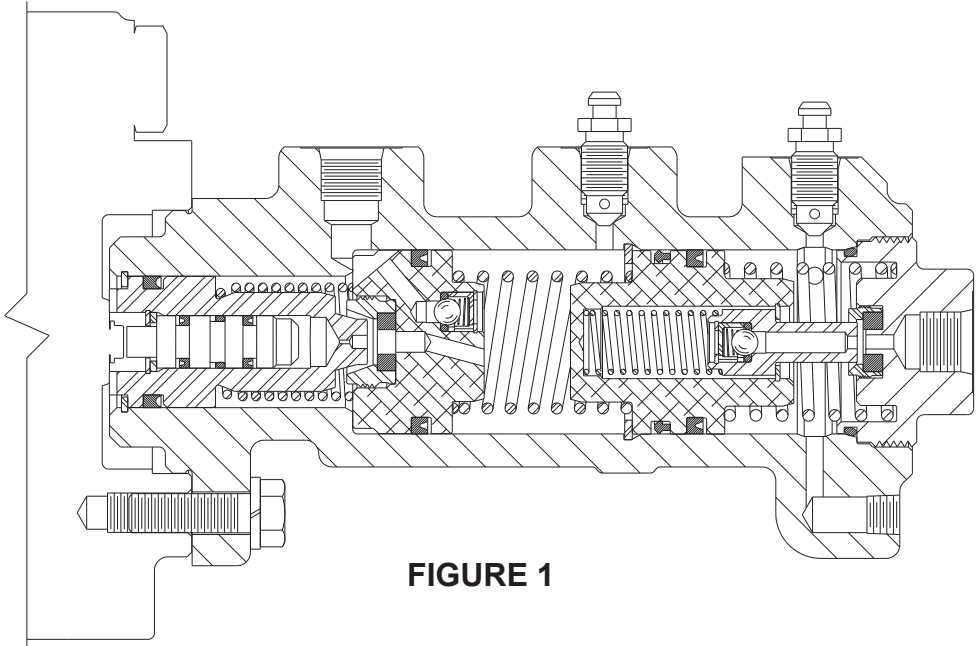

FIGURE 1

This instruction sheet services the Master Cylinder Section for this model number:  
02-460-380

NOTE: If your product number is not listed, contact ZF Off-Highway Solutions Minnesota Inc. for information.

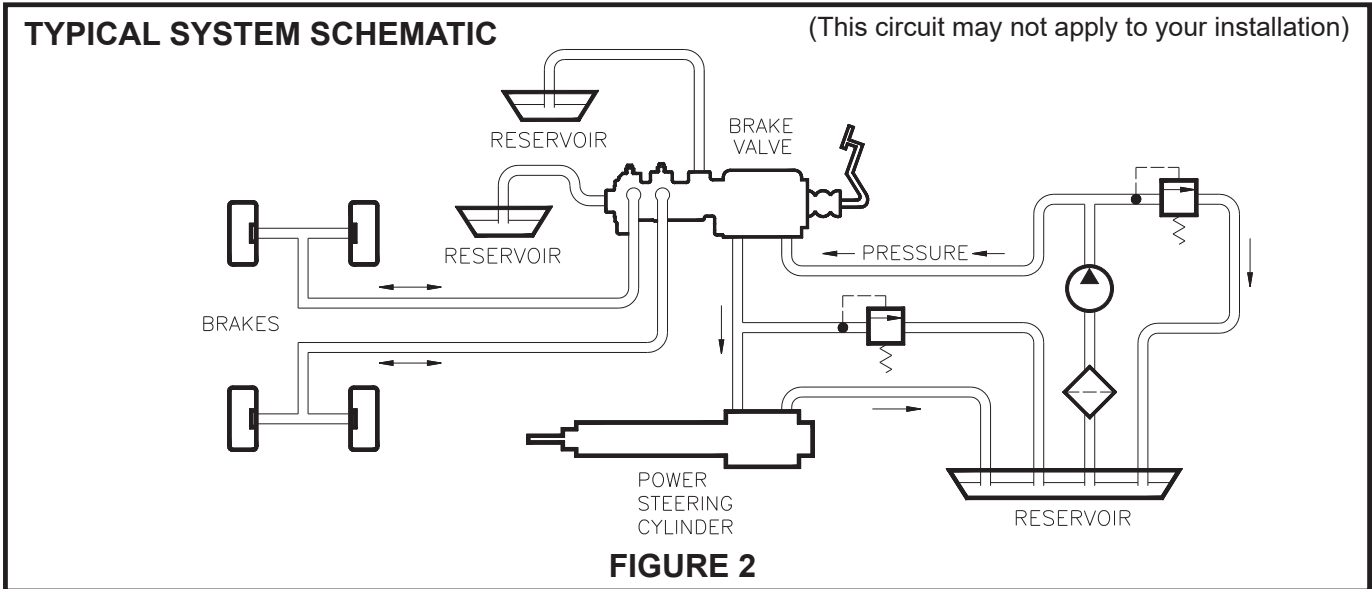

FIGURE 2

## REMOVING MASTER CYLINDER FROM THE MACHINE AND SEPARATING SECTIONS

(Refer to Figures 1 and 3)

1. Remove the master cylinder assembly from the machine by disconnecting the necessary fluid lines, disconnecting the push rod, and removing the mounting bolts. Drain fluid from the assembly.
2. Separate the master cylinder section from the power assist section by removing three cap screws and three lock washers.

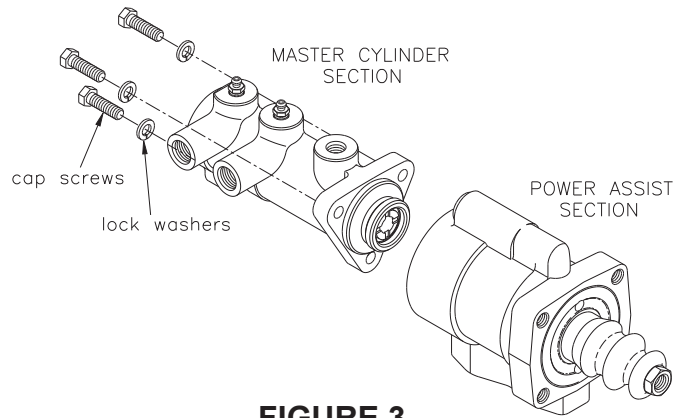

FIGURE 3

## CONNECTING SECTIONS AND MOUNTING MASTER CYLINDER ON THE MACHINE

(Refer to Figures 1 and 3)

1. Attach the master cylinder section to the power assist section with three cap screws and three lock washers. Torque the cap screws 29.8-36.6 N·m (22-27 ft·lb).
2. Install the master cylinder assembly on the machine. Connect the push rod. Connect the fluid lines. Bleed the system of air. Tighten fittings if leaks occur. Make several applications to be sure the master cylinder is working properly. **NOTE: All fittings must be inspected for leaks and tightened if leaks occur.**

## DISASSEMBLY

(Refer to Figures 1 and 4)

1. Drain fluid from the unit before disassembling.
2. Remove end plug (1) from housing (23).

### ⚠ CAUTION

End plug (1) is under tension of spring (5).

3. Remove o-ring (4), seat (2), and retainer (3) from end plug (1).
4. Remove spring (5) and piston assembly (18) from housing (23).
5. Remove retaining ring (6), piston assembly (13), spring (14), and cups (15 & 17) from piston (16).
6. Remove retaining ring (12), cage (11), tapered spring (10), ball (9), and o-ring (8) from piston (7).
7. Remove spring (19), retaining ring (20), and piston assembly (21) from housing (23). **NOTE: When removing retaining ring (20) be careful not to scratch or mar housing bore.**
8. Use a wooden dowel to push piston assembly (22) out of the large bore side of housing (23).
9. Remove retaining ring (28) from flange end of housing (23).
10. Remove two adapters (27), valves (25) and springs (24) from housing (23).

## DISASSEMBLY

(Refer to Figures 1 and 4)

**Use only automotive brake fluid in the master cylinder section.**

LUBRICATE ALL RUBBER COMPONENTS FROM THE REPAIR KIT WITH CLEAN TYPE FLUID USED IN THE SYSTEM.

1. Clean all parts thoroughly before assembling.
2. Install new retaining ring (28) in the flange side of housing (23).
3. Remove protective plastic cap from end of new piston assembly (22).
4. Install piston assembly (22) into large bore side of housing. Note direction of piston assembly.
5. Install new piston assembly (21) in housing (23). Note the direction of piston assembly (21).
6. Install retaining ring (20) in housing (23). **NOTE: When installing retaining ring (20) be careful not to scratch or mar housing bore.**
7. Install new spring (19) in housing (23).
8. Install new cups (15 & 17) on piston (16). Note the direction and order of cups (15 & 17), see Figure 4a.
9. Install new o-ring (8), new ball (9), new tapered spring (10), new cage (11), and new retaining ring (12) in piston (7). Note direction of cage (11) and tapered spring (10).
10. Install spring (14), piston assembly (13), and new retaining ring (6) in piston (16).
11. Install piston assembly (18) and spring (5) in housing (23). Note direction of piston assembly (18).
12. Install new seat (2) in new retainer (3) and install in end plug (1). Torque retainer (3) 16.3-19.0 N·m (12-14 lb·ft).
13. Install new o-ring (4) on end plug (1). Install end plug (1) in housing (23) and torque 33.9-47.5 N·m (25-35 lb·ft).
14. Install new o-rings (26) on new adapters (27). Install new springs (24), new valves (25), and new adapters (27) in housing (23). Torque adapters 61.0-67.8 N·m (45-50 lb·ft).

● Items included in Repair Kit

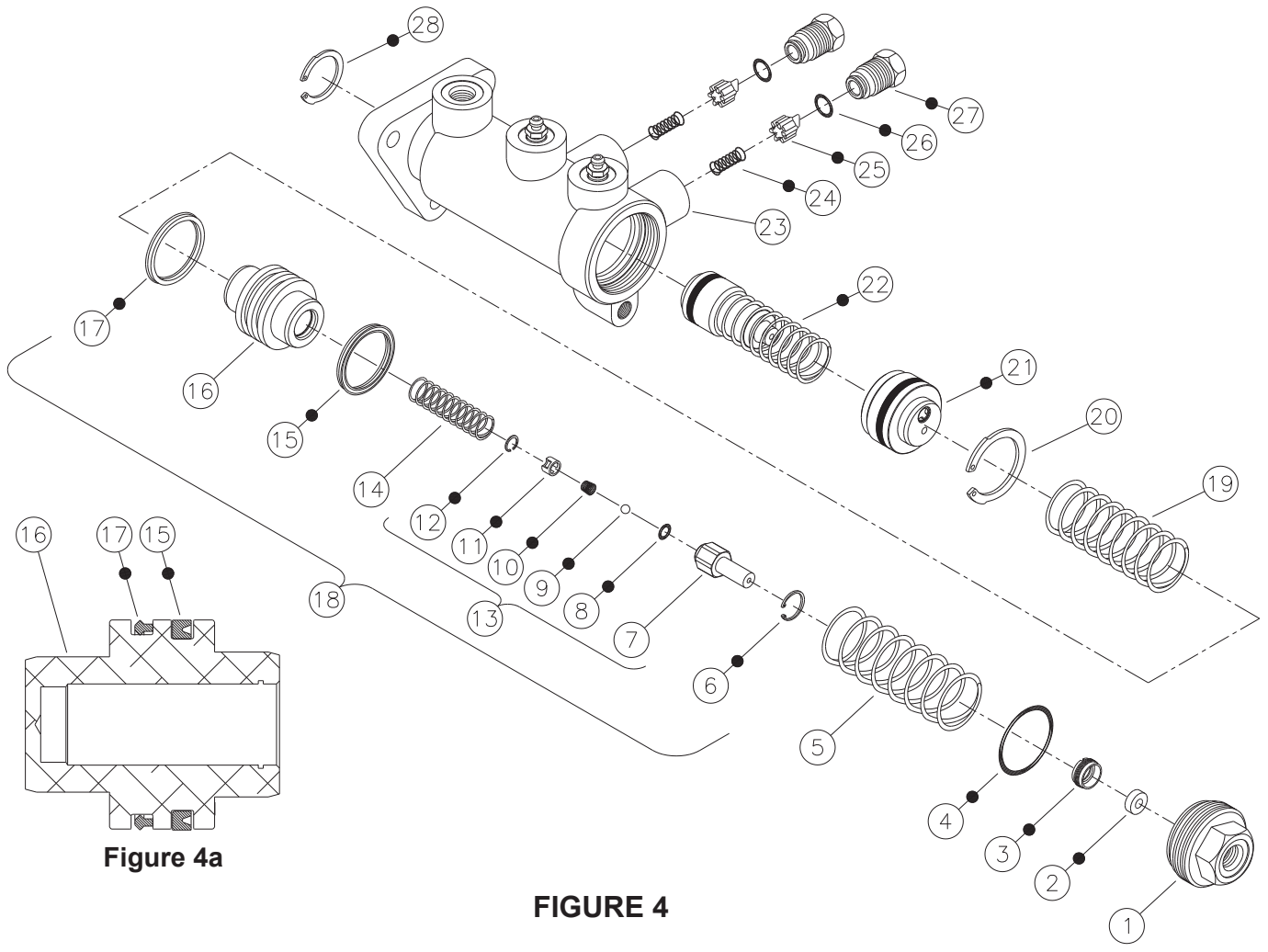

Figure 4a

FIGURE 4

# BLEEDING PROCEDURES

## NOTE

Use only proper fluid specified by machine manufacture. Never reuse fluid that has been drained from the system. Be sure that you maintain a high level of fluid in the reservoir during and after the entire bleeding process.

## PRESSURE BLEEDING INSTRUCTIONS

(Refer to Figure 5)

1. Master cylinder must be mounted to power assist section.
2. Connect primary and secondary remote reservoir lines and reservoirs.
3. Be certain all fittings are tight to avoid leaking.
4. Fill secondary remote reservoir with proper fluid. Fill slowly to prevent air entrapment in the reservoir lines.
5. Depress the pedal approximately two inches.
6. Connect the pressure bleeder to secondary reservoir adapter. Recommended bleeding pressure is 10 PSI maximum. **NOTE: Make sure to use the correct pressure bleeder for the type fluid used in system.**
7. Allow the pedal to return to the normal position.
8. Open the secondary bleeder screw on the master cylinder. Close the bleeder screw when air bubbles have ceased.
9. Working on the secondary line only, continue to the next bleeder screw and so on. At each point when air bubbles have ceased, close the bleeder screw.
10. Disconnect the pressure bleeder from the secondary reservoir adapter.

11. Fill the primary remote reservoir with proper fluid. Fill slowly to prevent air entrapment in the reservoir lines.
12. **DO NOT DEPRESS THE PEDAL.**
13. Connect the pressure bleeder to the primary reservoir adapter.
14. Open the primary bleeder screw on the master cylinder. Close the bleeder screw when air bubbles have ceased.
15. Working on the primary line only, continue to the next bleeder screw and so on. At each point when air bubbles have ceased, close the bleeder screw.
16. Disconnect the pressure bleeder from the primary reservoir adapter.
17. Open the primary and secondary bleeder screws on the master cylinder. Actuate the master cylinder to remove any residual air. Tighten the bleeder screw before allowing the pedal to return.
18. Depress the pedal several times. If the pedal is spongy, check for system leaks and repeat the bleeding process.

## GRAVITY BLEEDING PROCEDURE

(Refer to Figure 5)

1. Master cylinder must be securely mounted to power assist section.
2. Fill both primary and secondary reservoir with proper fluid.
3. Open both primary and secondary bleeder screws on the master cylinder.
4. Close both bleeder screws when air bubbles in fluid have ceased.
5. Open the downstream bleeder screws on the both primary and secondary lines.
6. Close both bleeder screws when air bubbles in fluid have ceased.
7. Open the downstream bleeder screws on the primary and secondary lines. Actuate the master cylinder to remove any residual air. Tighten both bleeder screws before allowing the pedal to return.
8. Depress the pedal several times. If the pedal is spongy, check for system leaks and repeat the bleeding process.

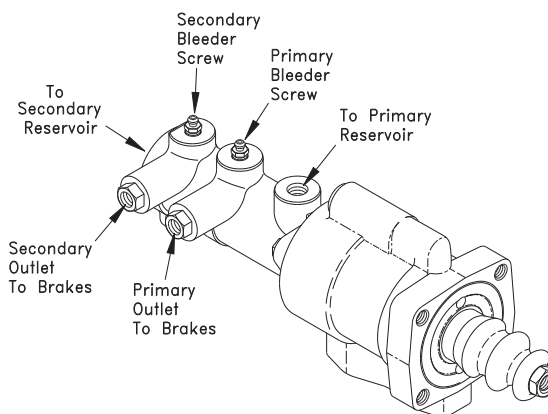

FIGURE 5

This publication is not subject to any update service. Information contained in this publication was in effect at the time the publication was approved for printing and is subject to change without notice or liability. ZF Off-Highway Solutions Minnesota Inc. reserves the right to revise the information presented or to discontinue the production of parts described at any time.

