

# BOOSTED MASTER CYLINDER (Master Cylinder Section)



## Service Instructions

MASTER CYLINDER SECTION - Automotive Brake Fluid

POWER ASSIST SECTION - Mineral Base Hydraulic Oil

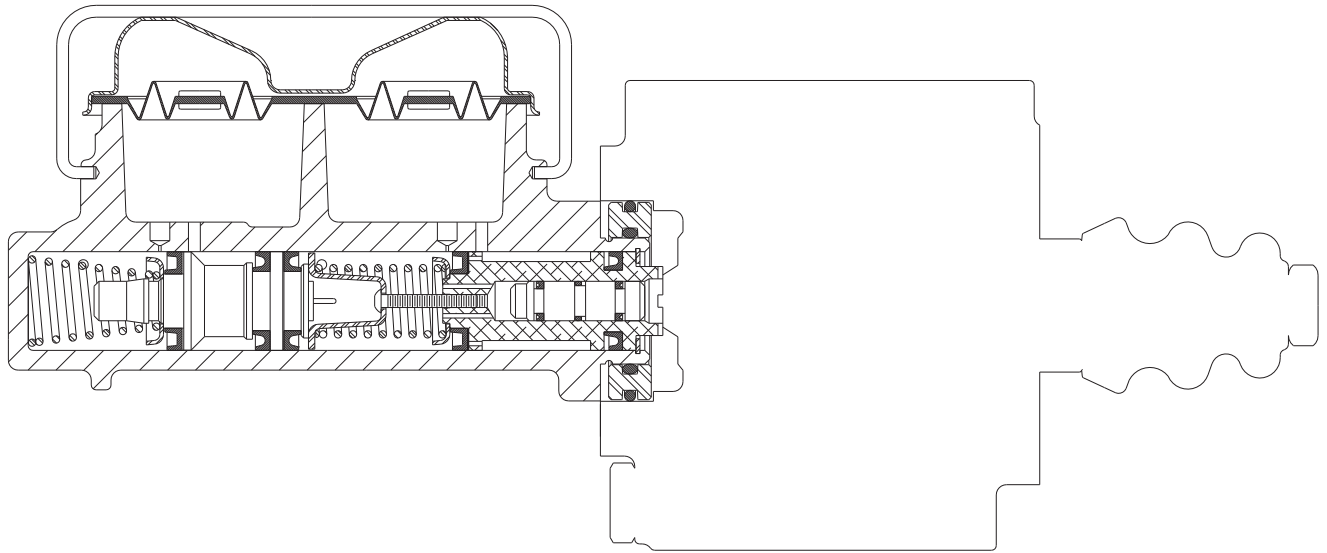

FIGURE 1

This instruction sheet services the Master Cylinder Section for these model number:  
02-460-374

NOTE: If your product number is not listed, please contact ZF Off-Highway Solutions Minnesota Inc. for information.

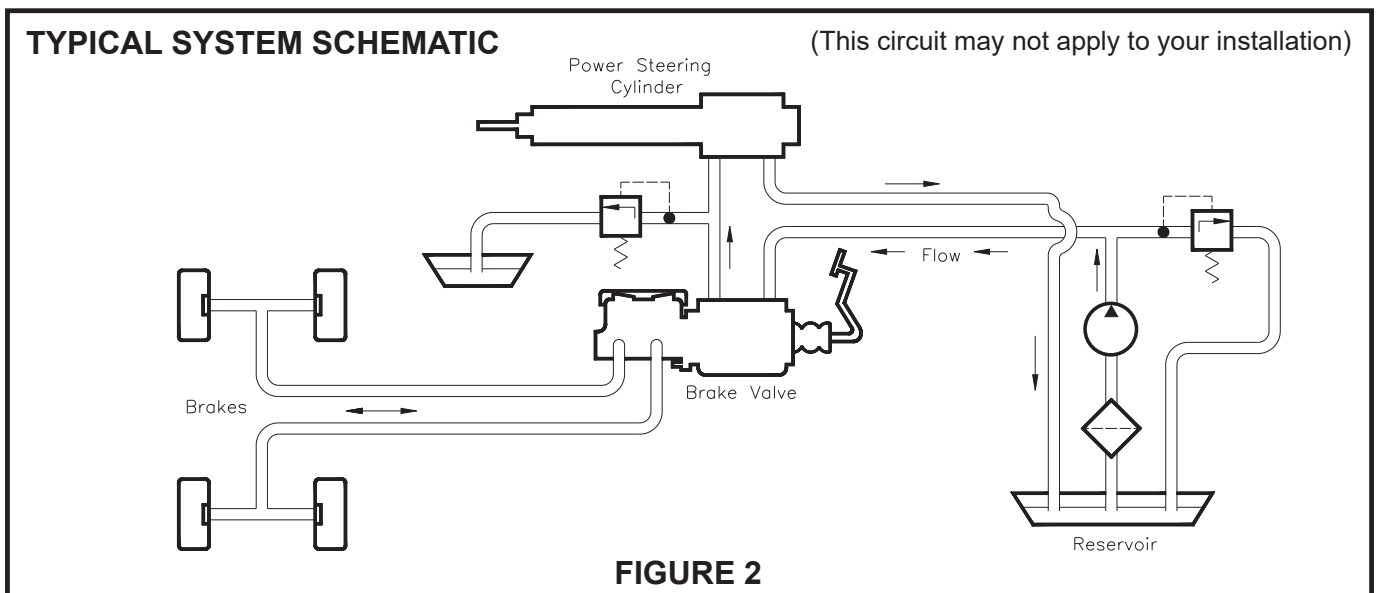
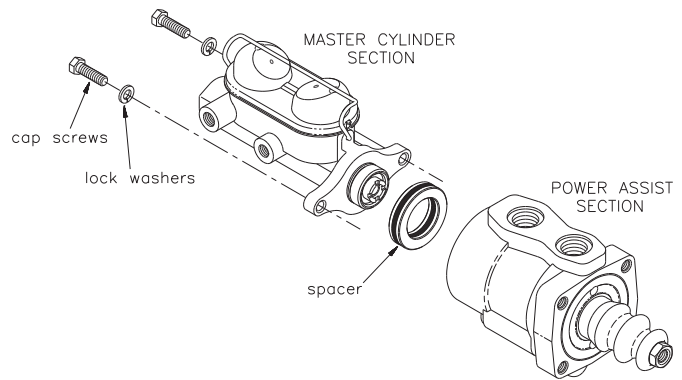

FIGURE 2

## REMOVING MASTER CYLINDER FROM THE MACHINE AND SEPARATING SECTIONS

(Refer to Figures 1 and 3)

1. Remove the master cylinder assembly from the machine by disconnecting the necessary fluid lines, disconnecting the push rod, and removing the mounting bolts. Drain the fluid from the assembly.
2. Separate the master cylinder section from the power assist section by removing two cap screws and two lock washers.



## CONNECTING SECTIONS AND MOUNTING MASTER CYLINDER ON THE MACHINE

(Refer to Figures 1 and 3)

1. Install the spacer between the two sections.
2. Attach the master cylinder section to the power assist section with two cap screws and two lock washers. Torque cap screws 29.8-36.6 N·m (22-27 lb·ft).
3. Install the master cylinder assembly on the machine. Connect the push rod. Connect the fluid lines. Fill the reservoir and bleed the system of air. Tighten fittings if leaks occur. Make several applications to be sure the master cylinder is working properly. **NOTE: All fittings must be inspected for leaks and tightened if leaks occur.**

FIGURE 3

### ⚠ CAUTION

If your vehicle is equipped with disc brakes, residual check valves (items 12, 13, & 14) must be removed.  
If your vehicle is equipped with drum brakes, residual check valves must be used.

## DISASSEMBLY

(Refer to Figures 1 and 4)

1. Remove spacer assembly (4) from housing (8).
2. Remove the master cylinder from the vehicle. Drain the fluid from the master cylinder.
3. Remove retaining ring (5) from housing (8).
4. Remove piston assemblies (6 & 7) from housing (8). **NOTE: Be careful not to scratch or mar the housing bore.**
5. Remove hook (11), cover (10), and diaphragm (9) from housing (8).
6. Use a no. 6 self tapping screw and washer to remove two inserts (12). See Figure 4a. Remove two valves (13) and two springs (14).
7. Remove screw (16) from housing (8). Remove o-ring (15) from screw (16). **NOTE: Not all models use screw (16) or o-ring (15).**

## ASSEMBLY

(Refer to Figures 1 and 4)

LUBRICATE ALL RUBBER COMPONENTS FROM REPAIR KIT WITH CLEAN TYPE FLUID USED IN THE SYSTEM.

1. Clean all parts thoroughly before assembling.
2. Install new piston assemblies (6 & 7) and new retaining ring (5) in housing (8). Note the order and direction of piston assemblies (6 & 7). **NOTE: Be careful not to scratch or mar piston assemblies or housing bore.**
3. Install two new springs (14), new valves (13), and new inserts (12) in housing (8). Use a wood or brass dowel to tap new inserts (12) into housing until the inserts bottom out in port.
4. Install diaphragm (9), cover (10), and hook (11), on housing (8).
5. Install new o-ring (15) on screw (16). Install screw (16) in housing and tighten. **NOTE: Not all models use screw (16) or o-ring (15).**
6. Install new o-rings (1 & 2) on spacer (3). Install spacer assembly (4) on housing.

● Items included in Repair Kit 02-400-171

\* Not used in all models

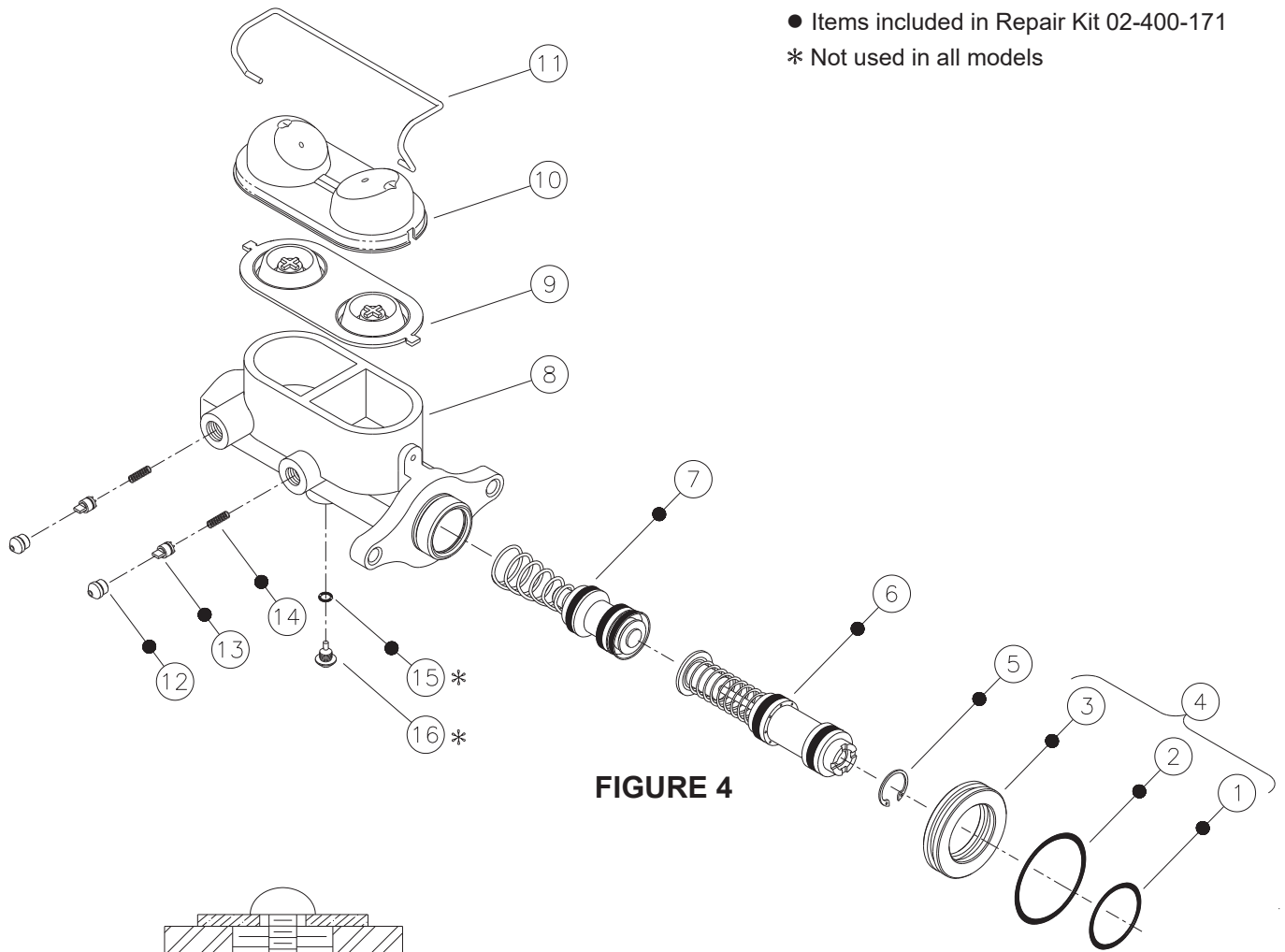

**FIGURE 4**

**Figure 4a**

# BLEEDING PROCEDURES

## NOTE

Use only proper fluid specified by the machine manufacture. Never reuse fluid that has been drained from the system. Be sure to maintain a high level of fluid in the reservoir during and after the entire bleeding process.

## PRESSURE BLEEDING INSTRUCTIONS

1. The master cylinder must be mounted to power assist section.
2. Fill the reservoir with proper fluid.
3. Be certain all fittings are tight to avoid leaking.
4. **DO NOT DEPRESS THE PEDAL.**
5. Connect pressure bleeder into reservoir adapter. Recommended bleeding pressure is 2.07 bar (30 PSI) maximum. **NOTE: Make sure to use correct pressure bleeder for type fluid used in the system.**
6. Open the bleeder screw closest to master cylinder outlet. Most of the air contained in the system will escape by this route. Close the bleeder screw.
7. Continue to the next bleeder screw and so on. At each point when air bubbles disappear close bleeder screw.
8. Remove the pressure bleeder.
9. Open the bleeder screw at master cylinder. Actuate the cylinder to remove any residual air. Tighten bleeder screw before allowing the pedal to return.
10. Depress pedal several times. If pedal is spongy, check for system leaks and repeat bleeding process.

## BENCH BLEEDING INSTRUCTIONS

(Refer to Figure 5)

1. This process can be done in a bench vise or on the machine with master cylinder mounted to power assist section.
2. Remove the master cylinder reservoir cover.
3. Connect a length of tubing to each of the outlet ports and immerse the other ends below the fluid level in each of the master cylinder reservoirs. Keep the reservoir fluid to within 12.7 mm (0.50 in) of inside reservoir top.
4. Actuate master cylinder piston using a smooth object large enough to hold the small internal piston from coming out. Slowly stroke and release master cylinder piston 34.9-38.1 mm (1.38-1.50 in). Repeat until air bubbles in reservoir have ceased.
5. Remove the tubing. This should be done quickly so the loss of fluid will be minimal.
6. If the master cylinder was bench bled in a vise, it must now be attached securely to the power assist section and mounted on the machine. Complete all plumbing connections before continuing to step 7.
7. Bleed remaining air from system by depressing brake pedal and opening the bleeder fitting closest to master cylinder. Close bleeder fitting before brake pedal is released. Continue to the next bleeder port. In all cases the bleeder fittings must be closed before the brake pedal is released or air will be pulled in through the bleeder and ingest unwanted air in the system.
8. Fill each reservoir to within 12.7 mm (0.50 in) of the top and install the reservoir cover.
9. Be certain all fittings are tight to avoid any leaking.
10. Depress the pedal several times. If brake pedal feels spongy, check for system leaks and repeat bleeding process.

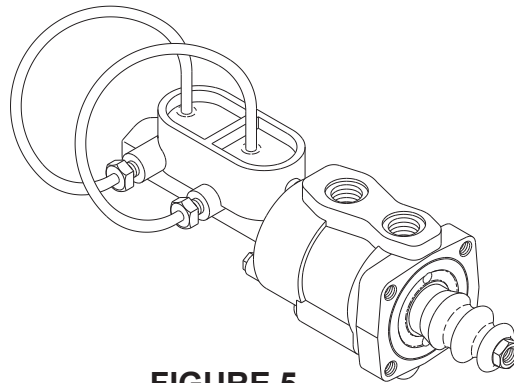

FIGURE 5

This publication is not subject to any update service. Information contained in this publication was in effect at the time the publication was approved for printing and is subject to change without notice or liability. ZF Off-Highway Solutions Minnesota Inc. reserves the right to revise the information presented or to discontinue the production of parts described at any time.

