

BOOSTED MASTER CYLINDER (Master Cylinder Section)



Service Instructions

MASTER CYLINDER SECTION - Automotive Brake Fluid

POWER ASSIST SECTION - Mineral Base Hydraulic Oil

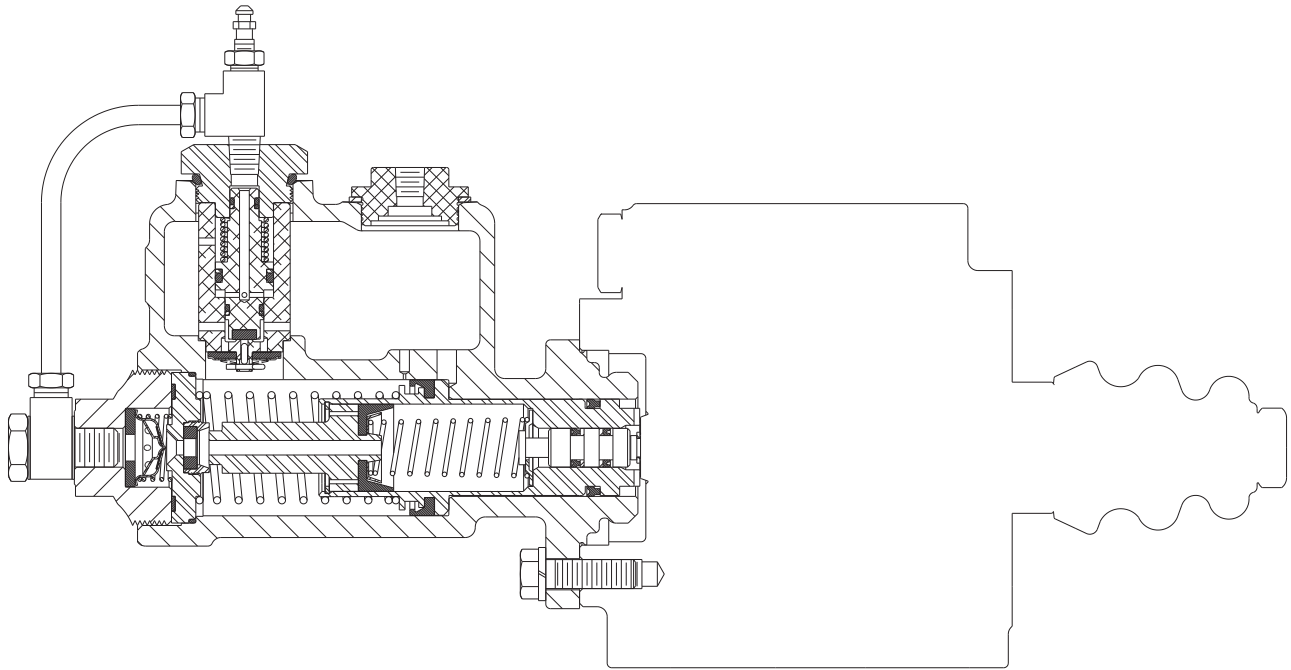

FIGURE 1

This instruction sheet services the Master Cylinder Section for these model numbers:

02-460-346

02-460-624

NOTE: If your product number is not listed, contact ZF Off-Highway Solutions Minnesota Inc. for information.

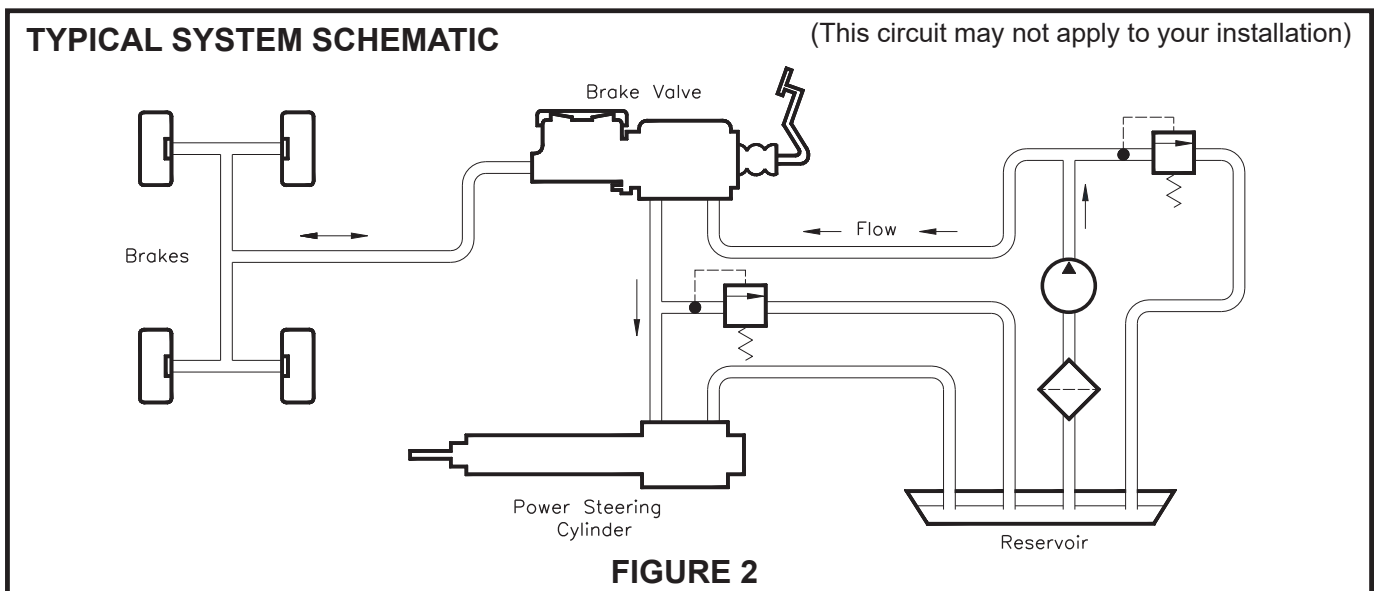

REMOVING MASTER CYLINDER FROM THE MACHINE AND SEPARATING SECTIONS

(Refer to Figures 1 and 3)

1. Remove the master cylinder assembly from the machine by disconnecting the necessary fluid lines, disconnecting the push rod, and removing the mounting bolts. Drain the fluid from the assembly.
2. Separate the master cylinder section from the power assist section by removing three cap screws and three lock washers.

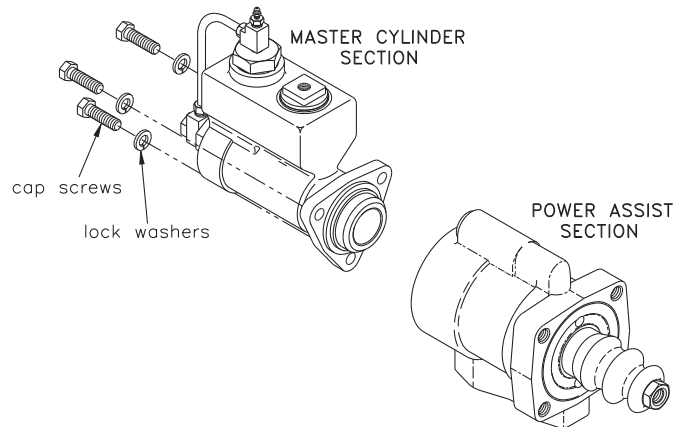

FIGURE 3

CONNECTING SECTIONS AND MOUNTING MASTER CYLINDER ON THE MACHINE

(Refer to Figures 1 and 3)

1. Attach the master cylinder section to the power assist section with three cap screws and three lock washers. Torque cap screws 29.8-36.6 N·m (22-27 lb·ft).
2. Install the master cylinder assembly on the machine. Connect the push rod. Connect the fluid lines. Fill the reservoir and bleed the system of air. Tighten fittings if leaks occur. Make several applications to be sure the master cylinder is working properly. **NOTE: All fittings must be inspected for leaks and tightened if leaks occur.**

DISASSEMBLY

(Refer to Figures 1 and 4)

1. Drain fluid from the unit before disassembling.
2. Remove upper tube nut on tubing assembly (28) from fitting (27).
3. Remove line bolt (1), gaskets (2 & 4), and fitting block (3). Tubing assembly (28) need not be removed from fitting block (3).
4. Remove end plug (5) using a large box end wrench.

⚠ CAUTION

End plug (5) is under tension of spring (12).

5. Remove spring (8), check valve (7), and seat (6) from end plug (5). **NOTE: Not all cylinders use spring (8), check valve (7), or seat (6).**
6. Retainer assembly (10) should follow end plug (5) as it is removed. Remove o-ring (11) from housing (23).
7. Remove spring (12) from housing (23).
8. Remove piston assembly (33) from housing (23) by pushing on piston assembly (33) with a wooden dowel from the small diameter end of housing (23).
9. Remove cups (20 & 22) from piston (21).
10. Depress piston (14) and remove retaining ring (13). Hold firmly, spring (17) will force piston (14) out of piston (21) bore. Remove cup (15) from piston (14).
11. Remove retainer (16) and spring (17).
12. Remove piston assembly (19) from piston (21) by pushing on piston assembly (19) with a wooden dowel from the small diameter end of piston (21).
13. Remove relief valve assembly (26) from housing (23). Remove end cap (29) using a box end wrench. Remove o-ring (30) from end cap (29). **NOTE: End cap is under tension of spring (31).**
14. Remove spring (31).
15. Remove filler cap (25) and gasket (24) from housing (23).

ASSEMBLY

(Refer to Figures 1 and 4)

Use only automotive brake fluid in the master cylinder section.

LUBRICATE ALL RUBBER COMPONENTS FROM THE REPAIR KIT WITH CLEAN TYPE FLUID USED IN THE SYSTEM.

1. Clean all parts thoroughly before assembling.
2. Install new slotted retainer (18) on new piston assembly (19) and gently insert into piston (21). Note direction of retainer (18).
3. Install new retainer (16) on end of spring (17). Install spring (17), large end first, into piston (21). **NOTE: Retainer (16) removed from your master cylinder may appear different than retainer (16) shown in Figure 4, replace with the new retainer provided in repair kit.**
4. Install new cup (15) on piston (14).
5. Insert piston (14) into piston (21) with cup (15) against retainer (16). Depress piston (14) and install new retaining ring (13).
6. Install new cup (20) and new cup (22) on piston (21).
7. Install piston assembly (33) into housing (23). Note direction of piston assembly.
8. Install spring (12) over piston assembly (33).
9. Install new o-ring (11) in housing (23). Install new seal (9) on new retainer assembly (10) and install retainer assembly (10) into housing (23). Note direction of retainer assembly (10).
10. Assemble new seat (6), new check valve (7), and spring (8) between retainer assembly (10) and end plug (5). **NOTE: Not all master cylinders use seat (6), check valve (7), or spring (8).**
11. Install end plug (5) in housing (23) and tighten end plug plug (5) using a large box end wrench to approximately 67.8-108.5 N·m (50-80 lb·ft).
12. Install new piston and body assembly (32) in housing (23).

- Items included in Repair Kit

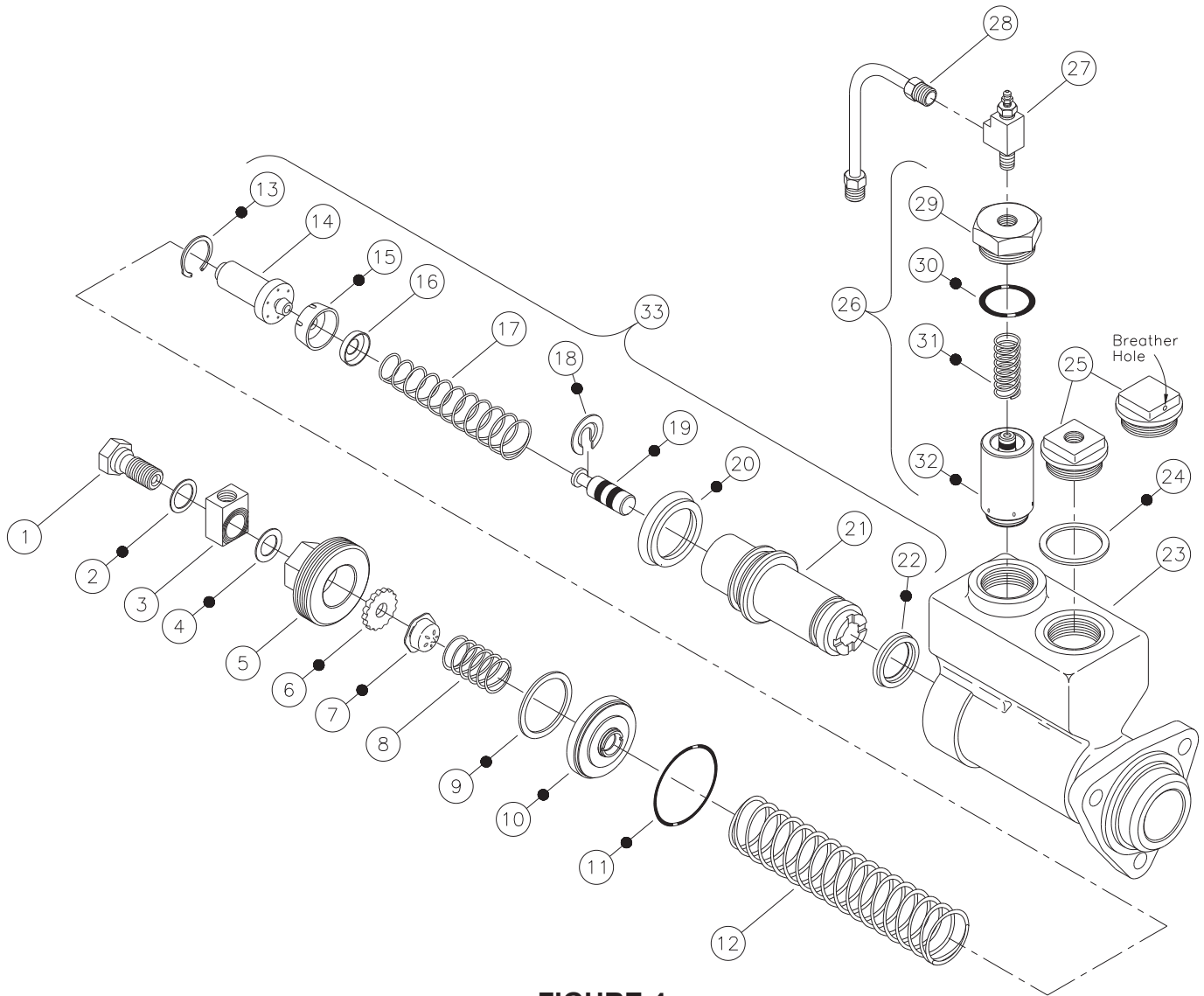

FIGURE 4

13. Install new spring (31).
14. Install new o-ring (30) on end cap (29).
15. Install end cap (29) into housing (23) and torque end cap 101.7-108.5 N·m (75-80 lb-ft).
16. Assemble new gaskets (2 & 4), fitting block (3), and line bolt (1) into end plug (5). Torque line bolt 47.5-61.0 N·m (35-45 lb-ft). **NOTE: Hold fitting block (3) in an upright fixed position while tightening line bolt (1).**
17. Install upper tube nut on tubing assembly (28) into fitting (27) and torque 12.2-20.3 N·m (9-15 lb-ft). Torque lower tube nut if necessary.
18. **NOTE: If your model uses a filler cap (25) with a breather hole, before installing filler cap be sure the breather hole is free of all contaminants. Use air pressure to clean and dry this hole.** Install new gasket (24) and filler cap (25) on housing (23).

BLEEDING PROCEDURES

NOTE

Use only proper fluid specified by the machine manufacture. Never reuse fluid that has been drained from the system. Be sure that you maintain a high level of fluid in the reservoir during and after the entire bleeding process.

PRESSURE BLEEDING INSTRUCTIONS

1. Master cylinder must be mounted to power assist section.
2. Fill reservoir with proper fluid.
3. Be sure all fittings are tight to avoid leaking.
4. **DO NOT DEPRESS THE PEDAL.**
5. Connect pressure bleeder into reservoir adapter. Recommended bleeding pressure is 2.07 bar (30 PSI) maximum. **NOTE: Make sure to use correct pressure bleeder for type fluid used in the system.**
6. Open bleeder screw closest to master cylinder outlet. Most of the air contained in the system will escape by this route. Close bleeder screw.
7. Continue to the next bleeder screw and so on. At each point when air bubbles disappear close bleeder screw.
8. Remove pressure bleeder.
9. Open bleeder screw at master cylinder. Actuate cylinder to remove any residual air. Tighten bleeder screw before allowing the pedal to return.
10. Depress pedal several times. If pedal is spongy, check for system leaks and repeat bleeding process.
11. Fill reservoir to within 12.7 mm (0.50 in) of top. Install filler cap and torque 33.9-40.7 N·m (25-30 lb·ft).

BENCH BLEEDING INSTRUCTIONS

(Refer to Figure 5)

1. This process can be done in a bench vise or on the machine with master cylinder mounted to power assist section.
2. Remove master cylinder filler cap.
3. Connect a length of tubing to an outlet port and immerse the other end below the fluid level in the master cylinder reservoir. Keep reservoir fluid within 12.7 mm (0.50 in) of inside reservoir top.
4. Actuate master cylinder piston with a smooth object large enough to hold the small internal piston from coming out. Slowly stroke and release master cylinder piston 34.9-38.1 mm (1.38-1.50 in). Repeat until air bubbles in reservoir have ceased.
5. Remove tubing. This should be done quickly so the loss of fluid will be minimized.
6. If cylinder was bench bled in a vise, it must now be attached securely to the power assist section and mounted on machine. Complete all plumbing connections before continuing to step 7.
7. Bleed remaining air from system by depressing brake pedal and opening bleeder fitting closest to the master cylinder. Close bleeder fitting before brake pedal is released. Continue to next bleeder port. In all cases the bleeder fittings must be closed before the brake pedal is released or air will be pulled in through the bleeder and ingest unwanted air in the system.
8. Fill reservoir to within 12.7 mm (0.50 in) of top. Install filler cap and torque 33.9-40.7 N·m (25-30 lb·ft).
9. Be sure all fittings are tight to avoid leaking.
10. Depress pedal several times. If the brake pedal feels spongy, check for system leaks and repeat bleeding process.

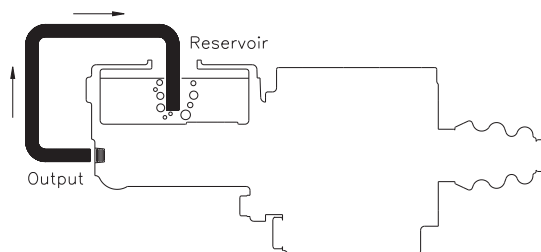

FIGURE 5

This publication is not subject to any update service. Information contained in this publication was in effect at the time the publication was approved for printing and is subject to change without notice or liability. ZF Off-Highway Solutions Minnesota Inc. reserves the right to revise the information presented or to discontinue the production of parts described at any time.

