

# BOOSTED MASTER CYLINDER (Master Cylinder Section)



## Service Instructions

**TABLE 1**

Model Number	Master Cylinder Repair Kit Number	Uses Seat (7) and Check Valve (8)	Model Number	Master Cylinder Repair Kit Number	Uses Seat (7) and Check Valve (8)
02-460-208 (BF)	02-400-134	No	02-460-394 (HO)	02-400-143	No
02-460-258 (BF)	02-400-123	Yes	02-460-396 (BF)	02-400-134	No
02-460-272 (BF)	02-400-184	Yes	02-460-398 (BF)	02-400-181	No
02-460-314 (BF)	02-400-134	No	02-460-418 (BF)	02-400-141	No
02-460-318 (BF)	02-400-139	Yes	02-460-430 (HO)	02-400-143	No
02-460-326 (BF)	02-400-141	No	02-460-468 (BF)	02-400-139	Yes
02-460-332 (HO)	02-400-143	No	02-460-482 (HO)	02-400-240	No
02-460-348 (HO)	02-400-143	No	02-460-496 (HO)	02-400-173	Yes
02-460-366 (BF)	02-400-141	No	02-461-378 (HO)	02-400-143	No
02-460-378 (HO)	02-400-173	Yes	02-461-496 (HO)	02-400-143	No

BF = Brake Fluid used in Master Cylinder Section

HO = Hydraulic Oil used in Master Cylinder Section

**NOTE: All models use Hydraulic Oil in Booster Section**

**NOTE: If your product number is not listed, contact ZF Off-Highway Solutions Minnesota Inc. for information.**

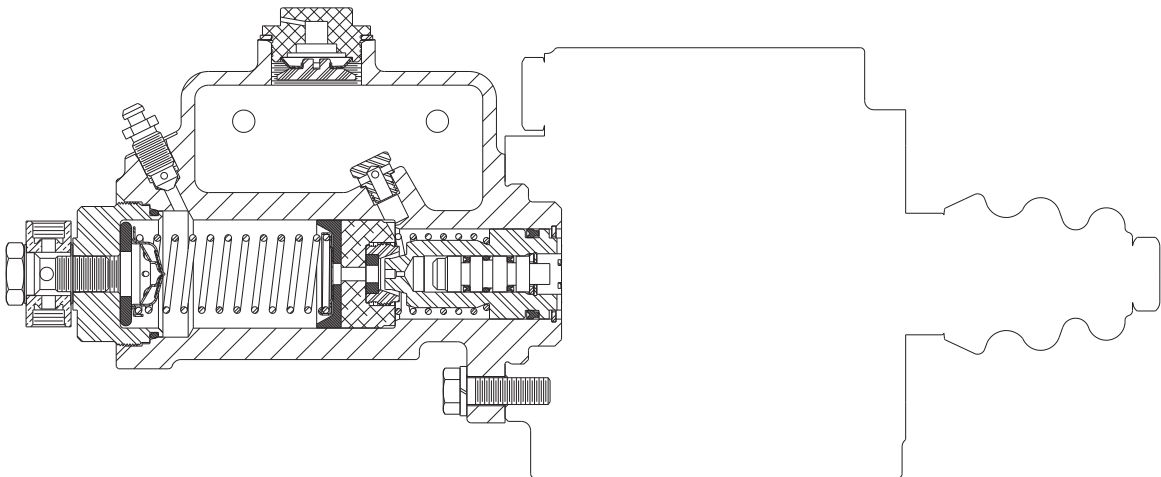

**FIGURE 1**

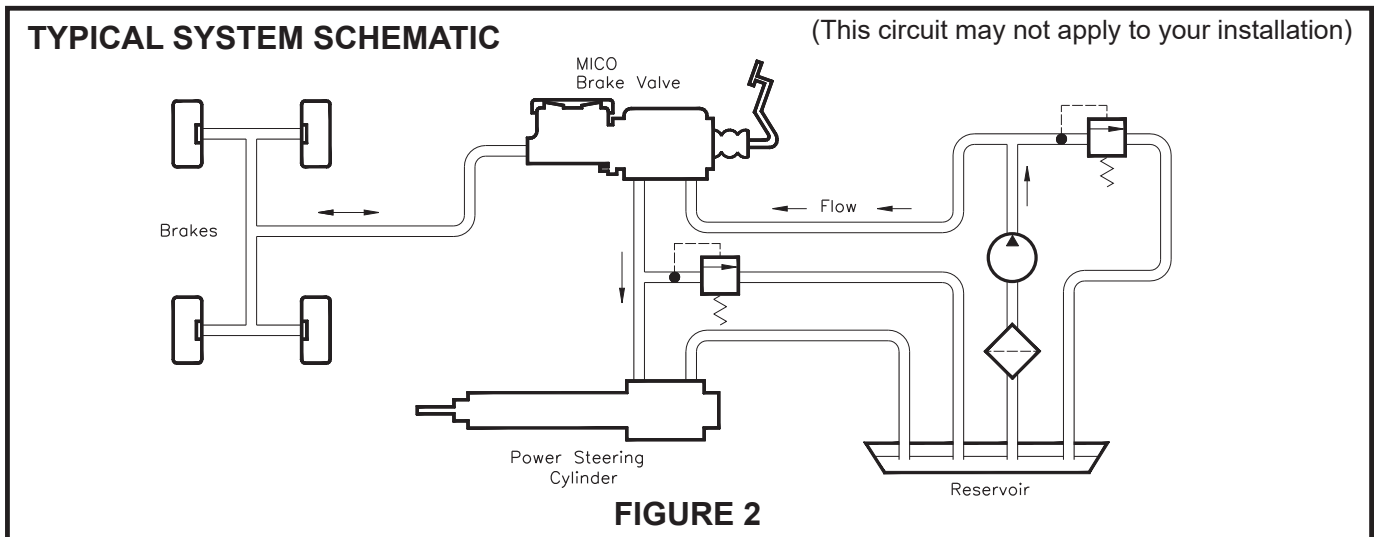
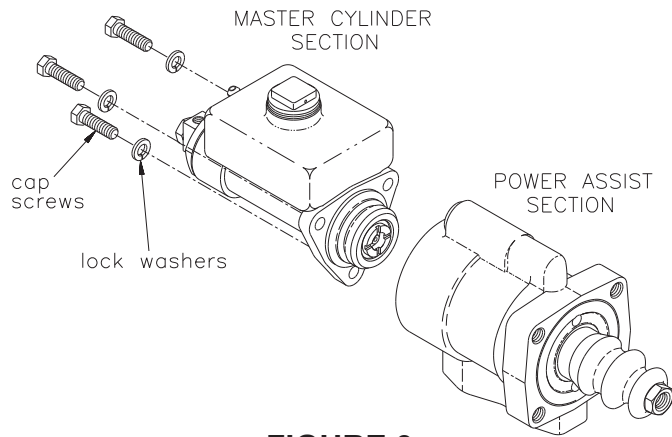

**FIGURE 2**

## REMOVING MASTER CYLINDER FROM THE MACHINE AND SEPARATING SECTIONS

(Refer to Figures 1 and 3)

1. Remove the master cylinder assembly from the machine by disconnecting the necessary fluid lines, disconnecting the push rod, and removing the mounting bolts. Drain the fluid from the assembly.
2. Separate the master cylinder section from the power assist section by removing three cap screws and three lock washers.



## CONNECTING SECTIONS AND MOUNTING MASTER CYLINDER ON THE MACHINE

(Refer to Figures 1 and 3)

1. Attach the master cylinder section to the power assist section with three cap screws and three lock washers. Torque cap screws 29.8-36.6 N·m (22-27 lb·ft).
2. Install the master cylinder assembly on the machine. For models that use a fitting block, hold fitting block (3) in a fixed position and torque line bolt (1) 47.5-61.0 N·m (35-45 lb·ft). Connect the push rod. Connect the fluid lines. Fill the reservoir and bleed the system of air.

FIGURE 3

Tighten fittings if leaks occur. Make several applications to be sure the master cylinder is working properly.

**NOTE: All fittings must be inspected for leaks and tightened if leaks occur.**

### NOTE

This literature services various master cylinder models. The components shown in Figures 1, 3, and 4 may appear different than what is found in your cylinder.

### DISASSEMBLY

(Refer to Figures 1 and 4)

1. Drain fluid from the unit before disassembling.
2. Remove line bolt (1), washer (2), fitting block (3), and washer (4) from end plug (5). **NOTE: Not all models use line bolt (1), washer (2), fitting block (3) or washer (4). Some models use an adapter in end plug (5). Remove adapter (1) and washer (2).**
3. Remove end plug (5) from housing (15).

### CAUTION

End plug (5) is under tension of springs (9 & 10).

4. Remove o-ring (6) from end plug (5).
5. Remove seat (7), check valve (8), springs (9 & 10), and cup (12) from housing. **NOTE: Not all models use seat (7) or check valve (8). See Table 1. Not all models use spring (9).**
6. Remove retainer (11) from spring (10).
7. Remove piston assembly (13) from housing (15).
8. Remove spring and piston assembly (14) from housing (15). **NOTE: Not all repair kits include a new spring with piston assembly (14). If not included in repair kit, re-use existing spring.**
9. Remove retaining ring (16) from housing (15).
10. Remove filler cap (18) and gasket (17) from housing (15).

### ASSEMBLY

(Refer to Figures 1 and 4)

LUBRICATE ALL RUBBER COMPONENTS FROM THE REPAIR KIT WITH CLEAN TYPE FLUID USED IN THE SYSTEM.

1. Clean all parts thoroughly before assembling.
2. Install new retaining ring (16) in housing (15).
3. Carefully install new spring and piston assembly (14) into housing (15). **NOTE: Not all repair kits include a new spring with piston assembly (14). If not included in repair kit, re-use existing spring.**
4. Install new piston assembly (13) into housing (15). Note direction of piston (13).
5. Insert new cup (12) into housing (15).
6. Install new retainer (11) on spring (10) by folding tabs. Insert springs (9 & 10) into housing, retainer end of spring (10) first. **NOTE: Not all models use spring (9).**
7. Install new seat (7), new check valve (8), and new o-ring (6) on end plug (5). **NOTE: Not all models use seat (7) or check valve (8). See Table 1.** Lubricate the threads on end plug (5) and install in housing (15). Torque end plug (5) 67.8-108.5 N·m (50-80 lb·ft).
8. Install new washer (4), fitting block (3), new washer (2) and line bolt (1) in end plug (5). Finger tighten line bolt (1). **NOTE: Not all models use washer (4), fitting block (3), washer (2), or line bolt (1). Some models use an adapter in end plug (5). Reinstall adapter (1) and new washer (2) and torque 47.5-61.0 N·m (35-45 lb·ft).**
9. **NOTE: Before installing filler cap (18) be sure the filler cap breather hole is free of all contaminants. Use air pressure to clean and dry this hole.** Install new gasket (17) and filler cap (18) on housing (15).

- Items included in Repair Kit
- \* Not used in all models

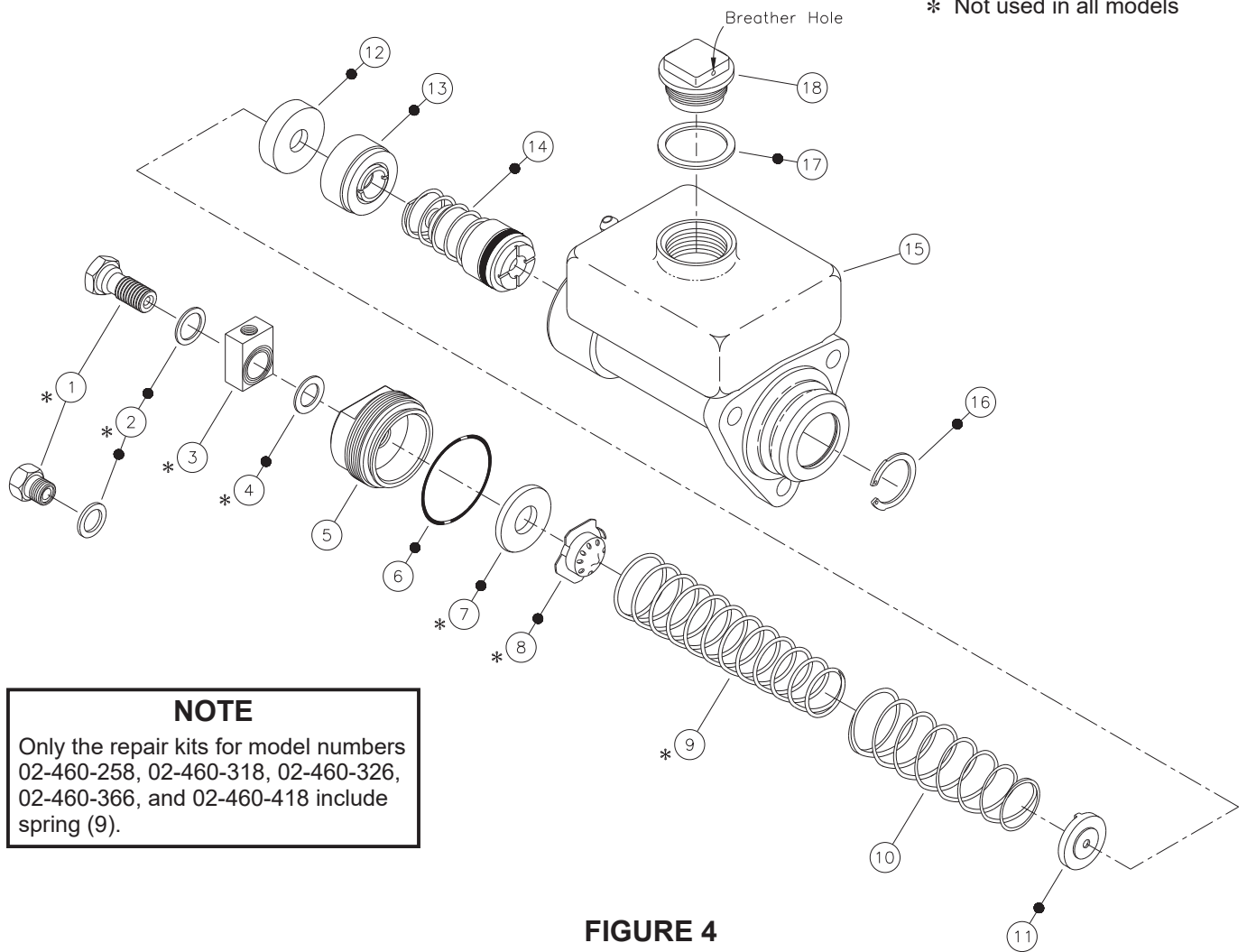

**NOTE**  
 Only the repair kits for model numbers 02-460-258, 02-460-318, 02-460-326, 02-460-366, and 02-460-418 include spring (9).

**FIGURE 4**

# BLEEDING PROCEDURES

## NOTE

Use only proper fluid specified by the machine manufacture. Never reuse fluid that has been drained from the system. Be sure that you maintain a high level of fluid in the reservoir during and after the entire bleeding process.

## PRESSURE BLEEDING INSTRUCTIONS

1. Master cylinder must be mounted to power assist section.
2. Fill reservoir with proper fluid.
3. Be sure all fittings are tight to avoid leaking.
4. DO NOT DEPRESS THE PEDAL.
5. Connect pressure bleeder into reservoir adapter. Recommended bleeding pressure is 2.07 bar (30 PSI) maximum. **NOTE: Make sure to use correct pressure bleeder for type fluid used in the system.**
6. Open bleeder screw closest to the master cylinder outlet. Most of the air contained in the system will escape by this route. Close bleeder screw.
7. Continue to the next bleeder screw and so on. At each point when air bubbles disappear close bleeder screw.
8. Remove the pressure bleeder.
9. Open bleeder screw at the master cylinder. Actuate cylinder to remove any residual air. Tighten bleeder screw before allowing the pedal to return.
10. Depress the pedal several times. If pedal is spongy, check for system leaks and repeat bleeding process.
11. Fill reservoir to within 12.7 mm (0.50 in) of top. Install filler cap and torque 33.9-40.7 N·m (25-30 lb·ft).

## BENCH BLEEDING INSTRUCTIONS

(Refer to Figure 5)

1. This process can be done in a bench vise or on the machine with master cylinder mounted to power assist section.
2. Remove master cylinder filler cap.
3. Connect a length of tubing to an outlet port and immerse the other end below the fluid level in the master cylinder reservoir. Keep reservoir fluid within 12.7 mm (0.50 in) of inside reservoir top.
4. Actuate master cylinder piston with a smooth object large enough to hold the small internal piston from coming out. Slowly stroke and release master cylinder piston. See CAUTION below. Repeat until air bubbles in reservoir have ceased.
5. Remove tubing. This should be done quickly so the loss of fluid will be minimized.
6. If cylinder was bench bled in a vise, it must now be attached securely to the power assist section and mounted on machine. Finish all plumbing connections before continuing to step 7.
7. Bleed remaining air from system by depressing brake pedal and opening bleeder fitting closest to master cylinder. Close the bleeder fitting

- before brake pedal is released. Continue to next bleeder port. In all cases the bleeder fittings must be closed before the brake pedal is released or air will be pulled in through the bleeder and ingest unwanted air in the system.
8. Fill reservoir to within 12.7 mm (0.50 in) of top. Install filler cap and torque 33.9-40.7 N·m (25-30 lb·ft).
9. Be sure all fittings are tight to avoid any leaking.
10. Depress pedal several times. If brake pedal feels spongy, check for system leaks and repeat the bleeding process.

## CAUTION

Care must be taken so as not to over stroke this cylinder. The cylinder does not incorporate a piston stop. Over stroking this cylinder may cause it to leak from push rod end of cylinder. Maximum recommended stroke for this cylinder is 31.8 mm (1.25 in).

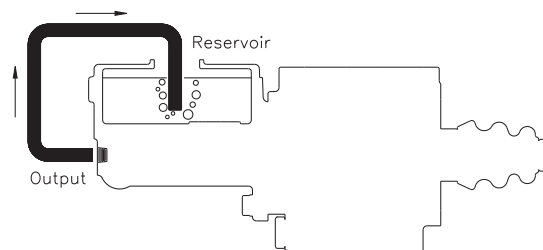

FIGURE 5

This publication is not subject to any update service. Information contained in this publication was in effect at the time the publication was approved for printing and is subject to change without notice or liability. ZF Off-Highway Solutions Minnesota Inc. reserves the right to revise the information presented or to discontinue the production of parts described at any time.

