

BOOSTED MASTER CYLINDER (Power Assist Section)



Service Instructions

MASTER CYLINDER SECTION - Automotive Brake Fluid

POWER ASSIST SECTION - Mineral Base Hydraulic Oil

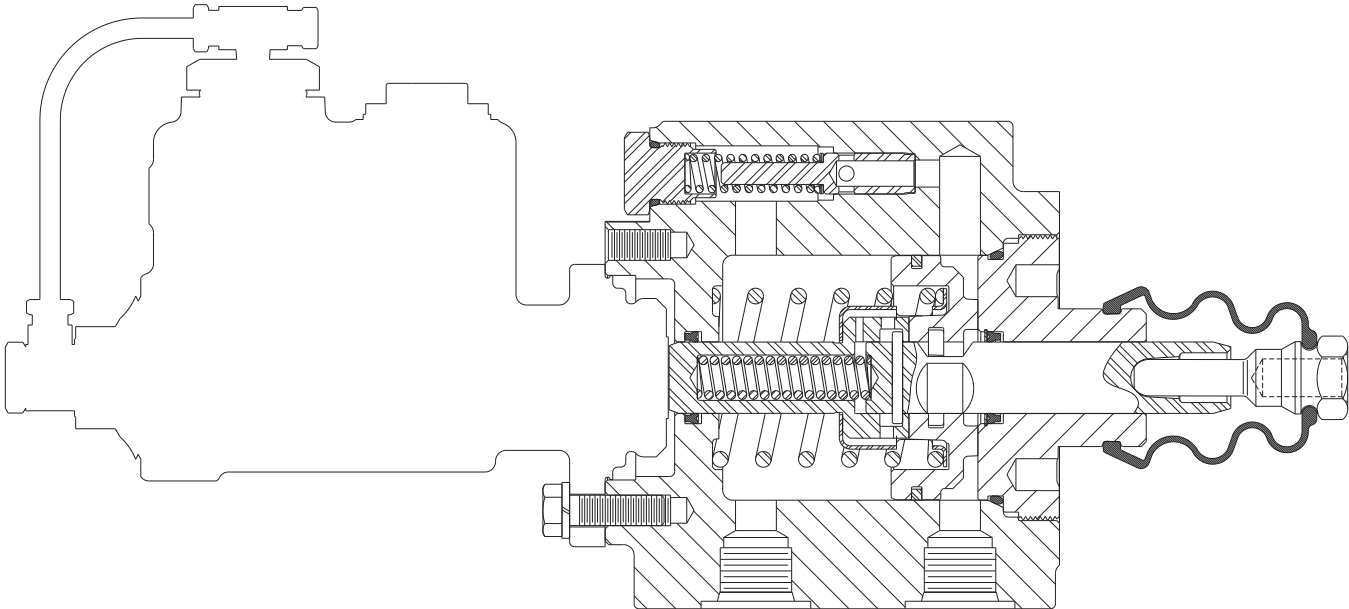
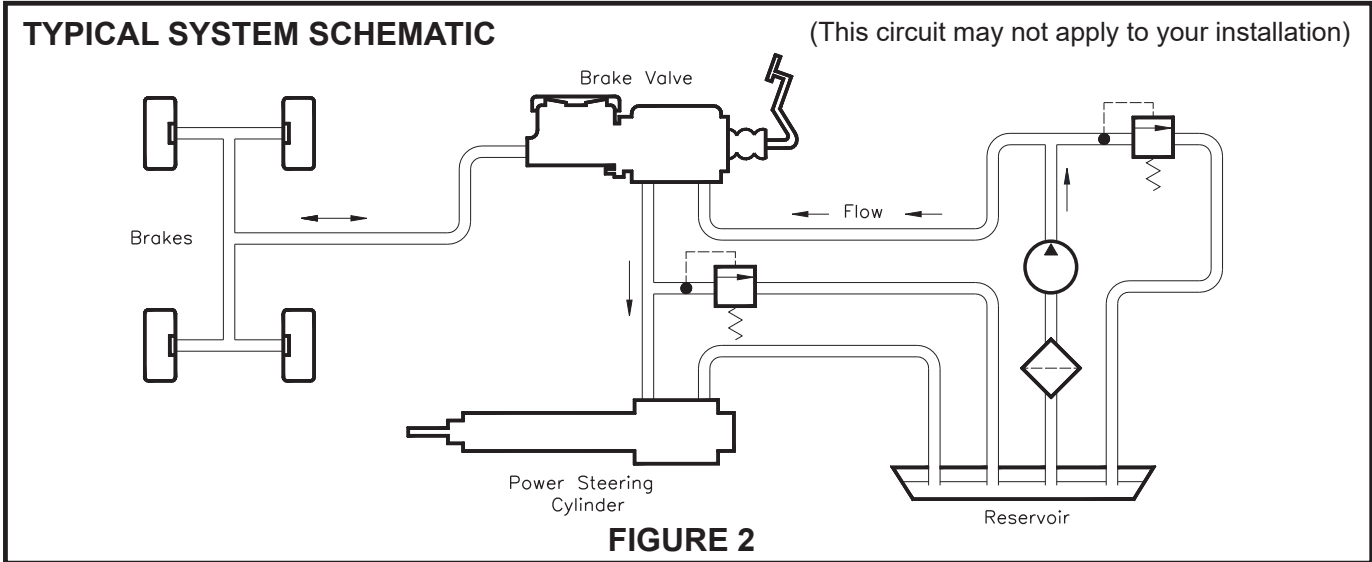

FIGURE 1

This instruction sheet services the Power Assist Section for these model numbers:

- 02-460-284
- 02-460-376
- 02-460-450

NOTE: If your product number is not listed, contact ZF Off-Highway Solutions Minnesota Inc. for information.



REMOVING MASTER CYLINDER FROM THE MACHINE AND SEPARATING SECTIONS

(Refer to Figures 1 and 3)

1. Remove the master cylinder assembly from the machine by disconnecting the necessary fluid lines, disconnecting the push rod, and removing the mounting bolts. Drain fluid from the assembly.
2. Separate the master cylinder section from the power assist section by removing three cap screws and three lock washers.

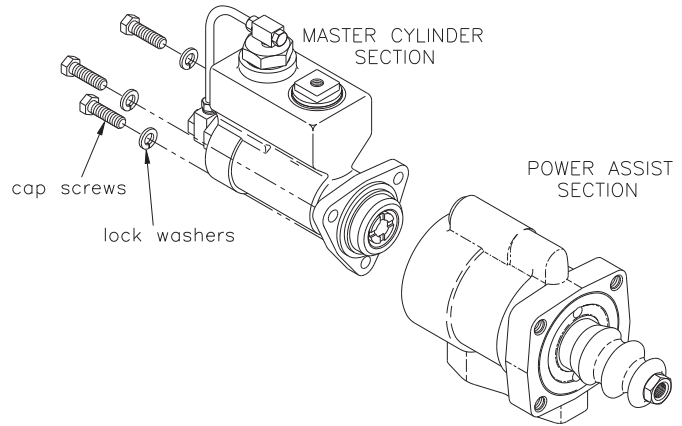

CONNECTING SECTIONS AND MOUNTING MASTER CYLINDER ON THE MACHINE

(Refer to Figures 1 and 3)

1. Attach the master cylinder section to the power assist section with three cap screws and three lock washers. Torque the cap screws 29.83-36.61 N·m (22-27 ft·lb).
2. Install the master cylinder assembly on the machine. Connect the push rod. Connect the fluid lines. Bleed the system of air. Tighten fittings if leaks occur. Make several applications to be sure the master cylinder is working properly. **NOTE: All fittings must be inspected for leaks and tightened if leaks occur.**

FIGURE 3

POWER ASSIST DISASSEMBLY

(Refer to Figures 1 and 4)

1. Drain fluid from unit before disassembling.
2. Remove push rod (1) and boot (2).
3. Remove end plug (3) with a spanner wrench.

⚠ CAUTION

End plug is under tension of spring (10).

4. Remove the internal parts assembly (11) from housing (12).
5. Remove o-ring (4) and cup (5) from end plug (3).
NOTE: Be careful not to scratch or mar end plug bore.
6. Remove piston (7) from piston (8). Remove piston ring (6) from piston (7).
7. Remove cup (13) from housing (12). **NOTE: Be careful not to scratch or mar housing bore.**
8. Remove plug (18) from housing (12).
9. Remove o-ring (17) from end plug (18).
10. Remove spring (16), shims (15), and valve stem (14) from housing (12).

POWER ASSIST ASSEMBLY

(Refer to Figures 1 and 4)

Use only Mineral Base Hydraulic Oil in Power Assist Section.

LUBRICATE ALL RUBBER COMPONENTS FROM THE REPAIR KIT WITH CLEAN TYPE FLUID USED IN THE SYSTEM.

1. Clean all parts thoroughly before assembling.
2. Install valve stem (14), shims (15), and spring (16) into housing (12).
3. Install new o-ring (17) on end plug (18) and install into housing. Torque end plug 40.7-54.2 N·m (30-40 lb·ft).
4. Install new cup (13) into housing bore. **NOTE: Be careful not to scratch or mar housing bore.**
5. Install new piston ring (6) on piston (7).
6. Install piston (7) on piston (8). Note direction of piston (7) in relation to piston (8).
7. Install new o-ring (4) and new cup (5) on end plug (3). Note direction of cup (5). **NOTE: Be careful not to scratch or mar end plug bore.**
8. Install end plug (3) on piston (8).
9. Install retainer (9) over piston (8) and install spring (10) over retainer (9).
10. Install internal parts assembly (11) into housing bore. Use a twisting motion when inserting piston (8) through cup (13) in housing bore. Torque end plug (3) 128.8-142.4 N·m (95-105 lb·ft).
11. Install new boot (2) on end plug (3). Install push rod (1) into boot.

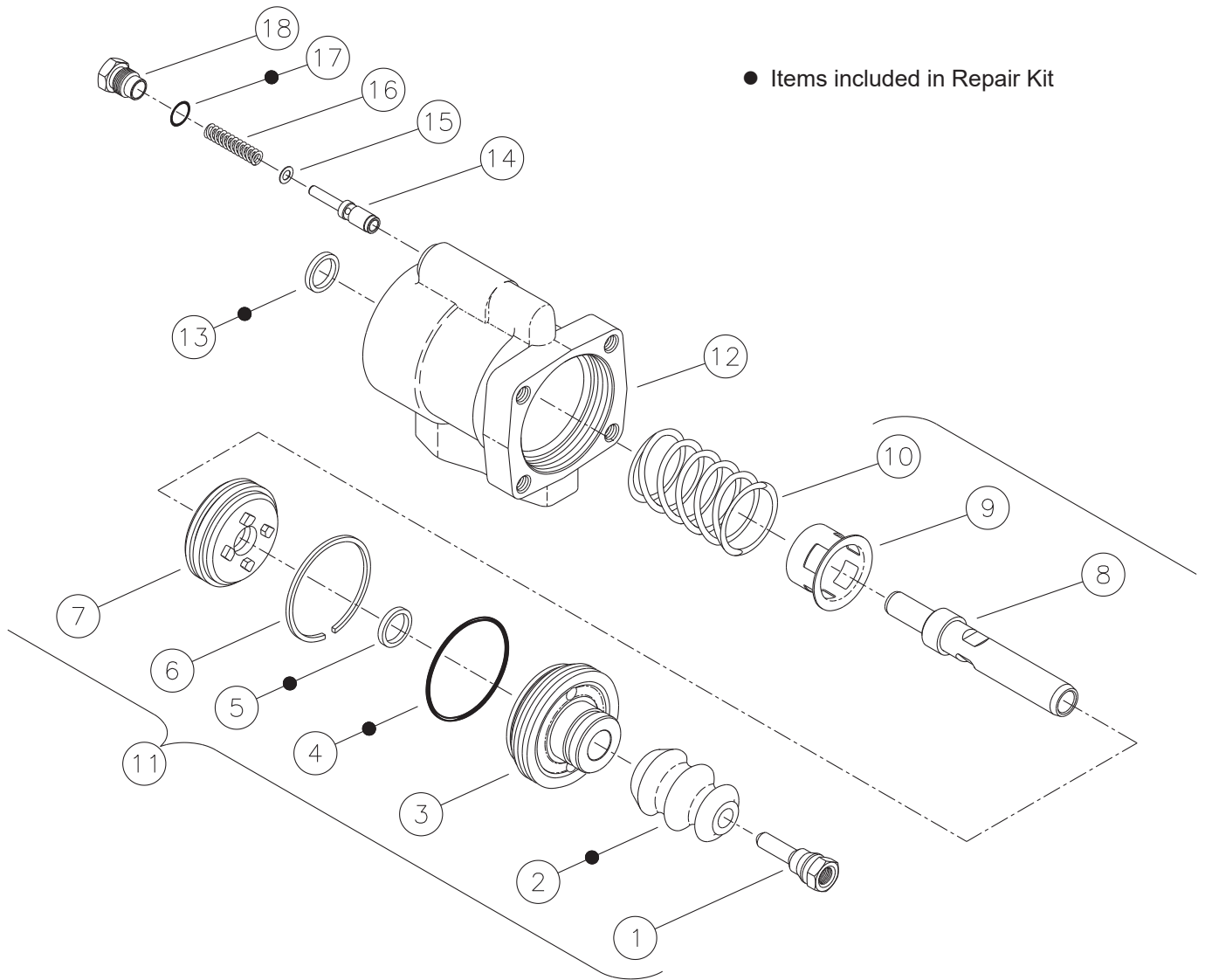

FIGURE 4

BLEEDING PROCEDURES

NOTE

Use only proper fluid specified by the machine manufacture. Never reuse fluid that has been drained from the system. Be sure that you maintain a high level of fluid in the reservoir during and after the entire bleeding process.

PRESSURE BLEEDING INSTRUCTIONS

1. Master Cylinder must be mounted to power assist section.
2. Fill reservoir with proper fluid.
3. Be certain all fittings are tight to avoid leaking.
4. **DO NOT DEPRESS THE PEDAL.**
5. Connect pressure bleeder into reservoir adapter. Recommended bleeding pressure is 2.07 bar (30 PSI) maximum. **NOTE: Make sure to use correct pressure bleeder for type fluid used in the system.**
6. Open bleeder screw closest to master cylinder outlet. Most of the air contained in the system will escape by this route. Close bleeder screw.
7. Continue to the next bleeder screw and so on. At each point when air bubbles disappear close bleeder screw.
8. Remove pressure bleeder.
9. Open bleeder screw at master cylinder. Actuate cylinder to remove any residual air. Tighten bleeder screw before allowing the pedal to return.
10. Depress pedal several times. If pedal is spongy, check for system leaks and repeat bleeding process.
11. Fill reservoir to within 12.7 mm (0.50 in) of top. Install filler cap and torque 33.9-40.7 N·m (25-30 lb·ft).

BENCH BLEEDING INSTRUCTIONS

(Refer to Figure 5)

1. This process can be done in a bench vise or on the machine with master cylinder mounted to power assist section.
2. Remove master cylinder filler cap.
3. Connect a length of tubing to an outlet port and immerse the other end below the fluid level in the master cylinder reservoir. Keep reservoir fluid within 12.7 mm (0.50 in) of inside reservoir top.
4. Actuate master cylinder piston with a smooth object large enough to hold the small internal piston from coming out. Slowly stroke and release master cylinder piston 34.9-38.1 mm (1.38-1.50 in). Repeat until air bubbles in reservoir have ceased.
5. Remove tubing. This should be done quickly so the loss of fluid will be minimized.
6. If cylinder was bench bled in a vise, it must now be attached securely to the power assist section and mounted on machine. Finish all plumbing connections before continuing to step 7.
7. Bleed remaining air from system by depressing brake pedal and opening bleeder fitting closest to the master cylinder. Close bleeder fitting before brake pedal is released. Continue to next bleeder port. In all cases the bleeder fittings must be closed before the brake pedal is released or air will be pulled in through the bleeder and ingest unwanted air in the system.
8. Fill reservoir to within 12.7 mm (0.50 in) of top. Install filler cap and torque 33.9-40.7 N·m (25-30 lb·ft).
9. Be sure all fittings are tight to avoid any leaking.
10. Depress pedal several times. If the brake pedal feels spongy, check for system leaks and repeat bleeding process.

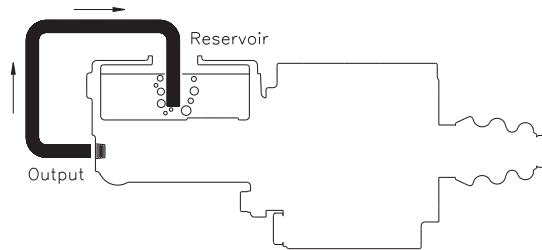

FIGURE 5

This publication is not subject to any update service. Information contained in this publication was in effect at the time the publication was approved for printing and is subject to change without notice or liability. ZF Off-Highway Solutions Minnesota Inc. reserves the right to revise the information presented or to discontinue the production of parts described at any time.

