

BOOSTED MASTER CYLINDER (Master Cylinder Section)



Service Instructions

MASTER CYLINDER SECTION - AUTOMOTIVE BRAKE FLUID POWER ASSIST SECTION - HYDRAULIC OIL

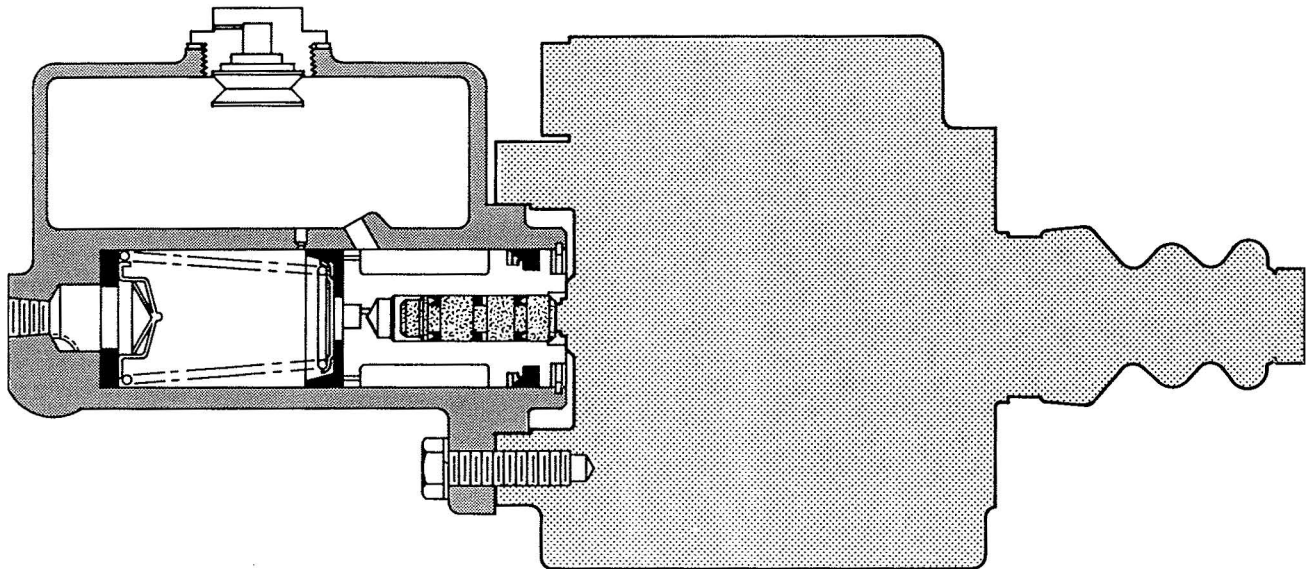

FIGURE 1

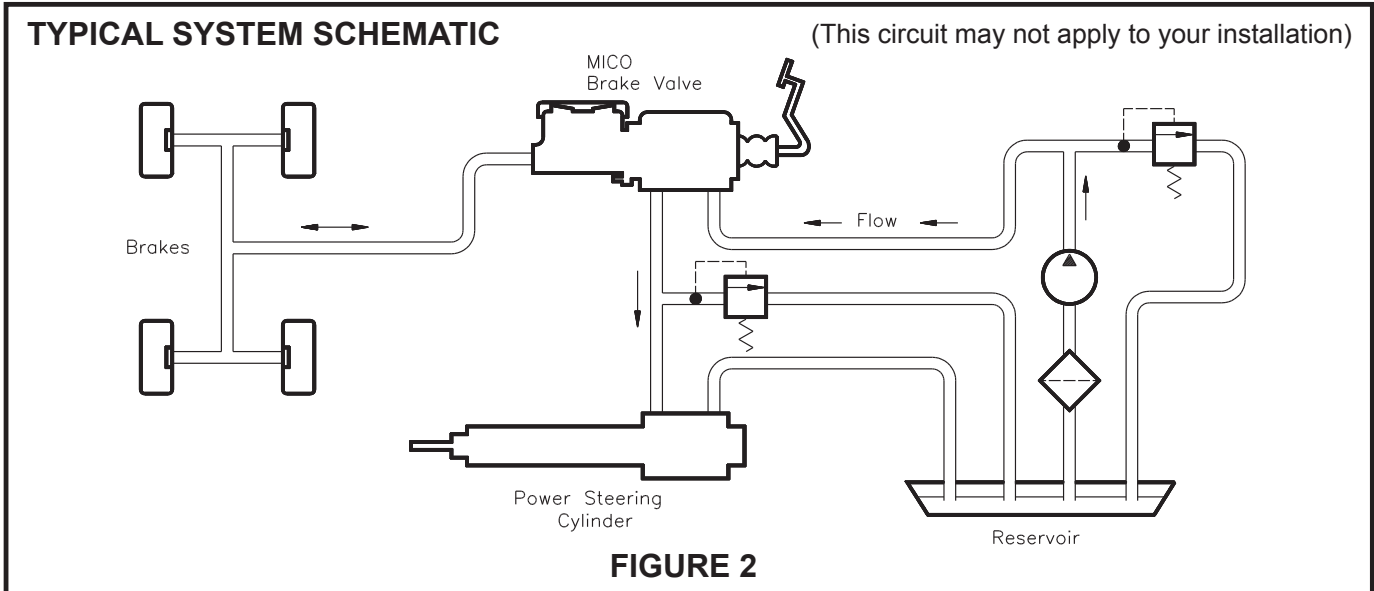

FIGURE 2

REMOVING BRAKE VALVE FROM VEHICLE AND SEPARATING SECTIONS

(Refer to Figures 1 and 3)

1. Remove brake valve from vehicle by disconnecting necessary fluid lines, disconnecting push rod, and removing mounting bolts. Drain fluid from assembly.
2. Separate Master Cylinder Section from Power Assist Section by removing three cap screws and three lockwashers.

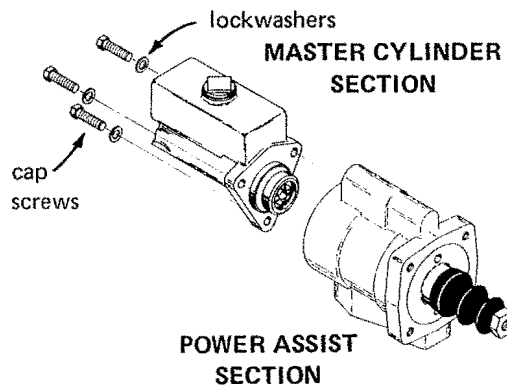

FIGURE 3

MASTER CYLINDER DISASSEMBLY

(Refer to Figures 1 and 4)

1. Drain fluid from unit before disassembling.
2. Remove retaining ring (item 1) from housing (item 8).
CAUTION: Retaining ring is under tension of spring (item 5).
3. Remove piston assembly (item 2) from cylinder bore.
4. Remove cup (item 3), retainer (item 4), spring (item 5), check valve (item 6), and seat (item 7) from housing.
NOTE: Not all cylinders contain a seat and check valve.
5. Remove filler cap (item 10) and gasket (item 9) from housing.

MASTER CYLINDER ASSEMBLY

(Refer to Figures 1 and 4) Use only automotive brake fluid in Master Cylinder Section.

LUBRICATE ALL RUBBER COMPONENTS FROM REPAIR KIT WITH CLEAN TYPE FLUID USED IN THE SYSTEM.

1. Clean all parts thoroughly before assembling.
2. Install new seat (item 7) and new check valve (item 6) in bore of housing (item 8). Install new check valve and new seat only if originally found in your cylinder.
3. Attach new retainer (item 4) to small end of spring (item 5). Now install spring and retainer assembly into housing bore with large end of spring over check valve (item 6).
4. Install new cup (item 3) over retainer (item 4). Note direction of cup.
5. Install new piston assembly (item 2) into housing bore. Note direction of piston.
6. Install new retaining ring (item 1) in housing.
7. Install new gasket (item 9) and filler cap (item 10) on housing (item 8).

- Items included in Repair Kit 02-400-092

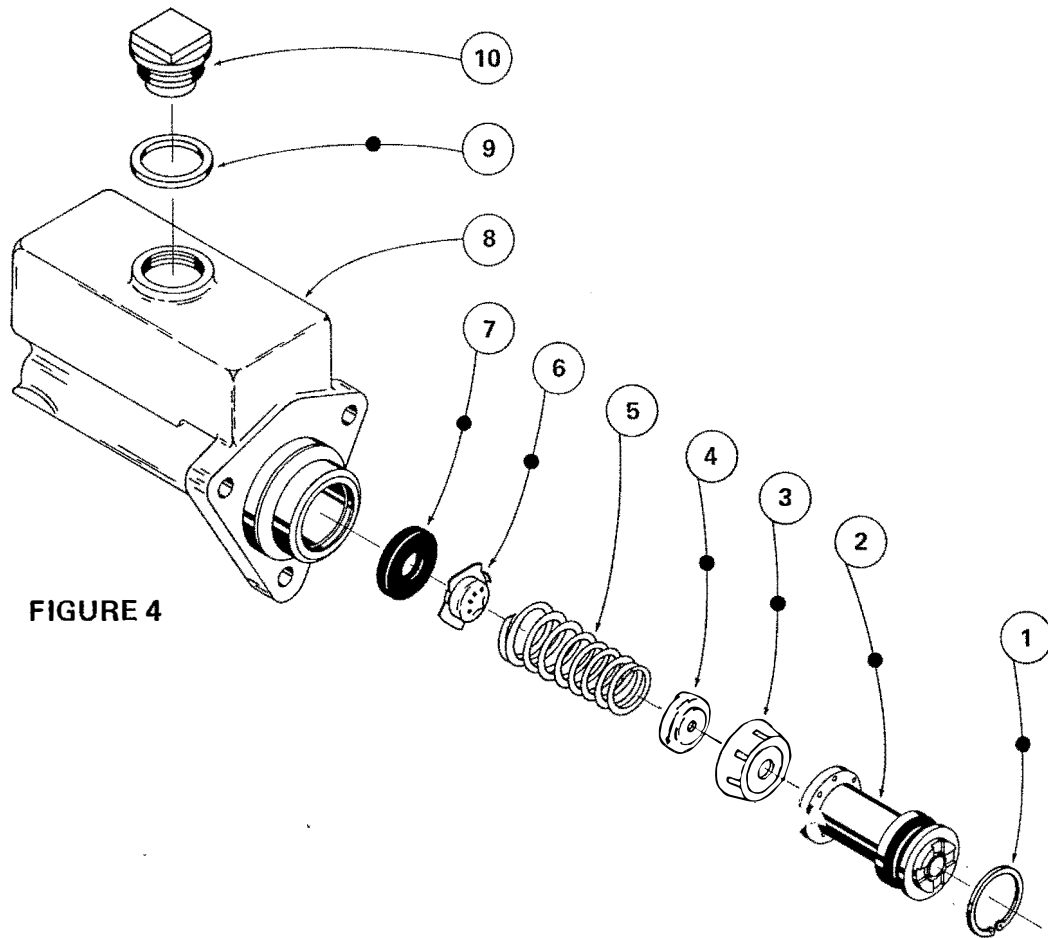

FIGURE 4

CONNECTING SECTIONS AND MOUNTING BRAKE VALVE ON VEHICLE

(Refer to Figures 1 and 3)

1. Attach Master Cylinder Section to Power Assist Section with three cap screws and three lockwashers. Torque 22 - 27 ft. lbs.
2. Install unit on vehicle. Connect push rod. Connect fluid lines. Bleed system of air. Tighten fittings if leaks should occur. Make several applications to be sure brake valve is working properly.

BLEEDING PROCEDURES

NOTE

Use only proper fluid specified by vehicle manufacturer. Never reuse fluid that has been drained from the system. Be sure that you maintain a high level of fluid in the reservoir during and after the entire bleeding process.

PRESSURE BLEEDING INSTRUCTIONS

1. Master Cylinder must be securely mounted to power assist section.
2. Fill reservoir with proper fluid.
3. Be certain all fittings are tight to avoid leaking.
4. DO NOT DEPRESS PEDAL.
5. Connect pressure bleeder into reservoir adapter. Recommended bleeding pressure is 2.07 bar (30 psi) maximum. **NOTE: Make sure to use correct pressure bleeder for type fluid used in system.**
6. Open bleeder screw closest to master cylinder outlet. Most of the air contained in the system will escape by this route. Close bleeder screw.
7. Continue to the next bleeder screw and so on. At each point when air bubbles disappear close bleeder screw.
8. Remove pressure bleeder.
9. Open bleeder screw at master cylinder. Actuate cylinder to remove any residual air. Tighten bleeder screw before permitting pedal to return.
10. Actuate pedal several times. If pedal is spongy, check for system leaks and repeat bleeding process.

BENCH BLEEDING INSTRUCTIONS

(Refer to Figure 5)

1. This process can be done in a bench vise or on the vehicle with master cylinder mounted to power assist section.
2. Remove master cylinder filler cap assembly.
3. Connect a length of tubing to an outlet port and immerse the other end below the fluid level in the master cylinder reservoir. Keep reservoir fluid within 12.7 mm (.50") of inside reservoir top.
4. Actuate master cylinder piston with a smooth object large enough to hold the small internal piston from coming out. Slowly stroke and release master cylinder piston. **See CAUTION below.** Repeat until air bubbles in reservoir have ceased.
5. Remove tubing. This should be done quickly so the loss of fluid will be minimized.
6. If cylinder was bench bled in a vise, it must now be attached securely to the power assist section and mounted on vehicle. Finish all plumbing connections before continuing to step 7.
7. Bleed remaining air from system by

- depressing brake pedal and opening bleeder fitting closest to master cylinder. Close bleeder fitting before brake pedal is released. Continue to next bleeder port. In all cases the bleeder fittings must be closed before the brake pedal is released or air will be pulled in through the bleeder and ingest unwanted air in the system.
8. Fill reservoir to within 12.7 mm (.50") of top and install filler cap assembly.
9. Be certain all fittings are tight to avoid any leaking.
10. Actuate pedal several times. If brake pedal feels spongy, check for system leaks and repeat bleeding process.

CAUTION

Care must be taken so as not to over stroke this cylinder. The cylinder does not incorporate a piston stop. Over stroking this cylinder may cause it to leak from push rod end of cylinder. Maximum stroke for this cylinder is 31.75 mm (1.25").

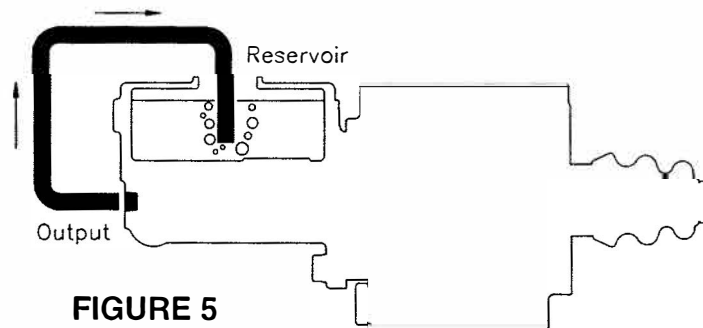

FIGURE 5

This publication is not subject to any update service. Information contained in this publication was in effect at the time the publication was approved for printing and is subject to change without notice or liability. ZF Off-Highway Solutions Minnesota Inc. reserves the right to revise the information presented or to discontinue the production of parts described at any time.

