

# MASTER CYLINDER (Air Actuated)



## Service Instructions

TABLE 1

Model Number	Repair Kit Number	Air Chamber Replacement Kit Number
02-460-580	02-400-223	02-001-312
02-461-580	02-400-223	02-001-312
03-460-436	02-400-223	02-001-301
03-460-437	02-400-223	02-001-309

NOTE: If your product number is not listed, please contact ZF Off-Highway Solutions Minnesota for information.

### NOTE

This literature services various models in this actuator series. The components shown in Figures 1 and 2 may appear different than what is found in your actuator.

## SEPARATING AIR CHAMBER AND MASTER CYLINDER

(Refer to Figures 1)

1. Remove air/hydraulic actuator from the machine by disconnecting the necessary air and fluid lines, and removing mounting bolts. Drain fluid from assembly.
2. Separate air chamber from mounting bracket and master cylinder by removing two nuts and two lock washers or spacers. **NOTE: Model number 03-460-436 does not require this step. Proceed to page 2 instructions.**

## CONNECTING AIR CHAMBER AND MASTER CYLINDER

(Refer to Figures 1)

LIGHTLY LUBRICATE PUSH ROD WITH MOLY IMPREGNATED GREASE.

1. Fit mounting bracket and flange end of master cylinder over the threaded studs of the air chamber. Install lock washers or spacers and nuts on the studs and torque 97.6-105.8 N·m (72-78 lb-ft). **NOTE: Model number 03-460-436 does not require this step.**
2. Install unit on vehicle. Connect air and fluid lines. Bleed fluid system of air. Tighten fittings if leaks occur. Make several applications to be sure the actuator is functioning properly.

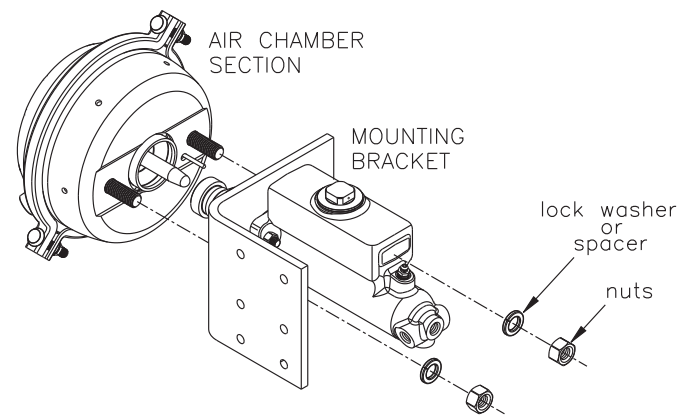

FIGURE 1

This publication is not subject to any update service. Information contained in this publication was in effect at the time the publication was approved for printing and is subject to change without notice or liability. ZF Off-Highway Solutions Minnesota Inc. reserves the right to revise the information presented or to discontinue the production of parts described at any time.



ZF Off-Highway Solutions Minnesota Inc.

1911 Lee Boulevard / North Mankato, MN U.S.A. 56003

Tel: +1 507 625 6426 Fax: +1 507 625 3212

## MASTER CYLINDER DISASSEMBLY

(Refer to Figure 2)

1. If necessary, separate master cylinder (5) from mounting bracket (2) by removing four screws (1), nuts (4), and lock washers (3). **NOTE: Model number 03-460-436 will require the removal of these items. See Figure 2b.**
2. Remove guide (9) and boot (10) from cylinder. Carefully remove o-ring (8) from guide (9). **NOTE: Be careful not to scratch or mar guide (9) bore. Not all models use guide (9), o-ring (8), or boot (10).**
3. Remove retaining ring (4) from housing (11).

<b>⚠ CAUTION</b>
Retaining ring is under tension of spring (16).

4. Remove spacer (12), piston (14), cup (15), spring (16), check valve (17) and seat (18) from housing bore.
5. Carefully remove cup or quad ring (13) from piston (14). **NOTE: Earlier models use a cup and later models use a quad ring. Be careful not to scratch or mar piston (14).**
6. Remove filler plug (6) and gasket (7) from housing.

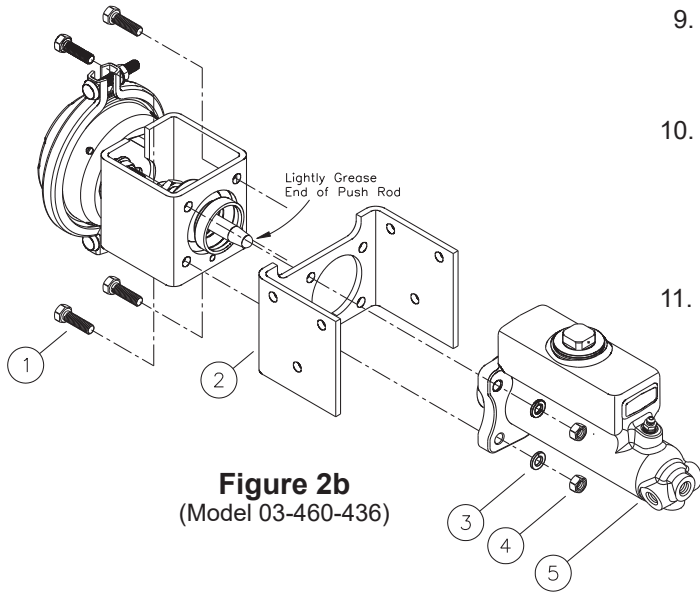

**Figure 2b**  
(Model 03-460-436)

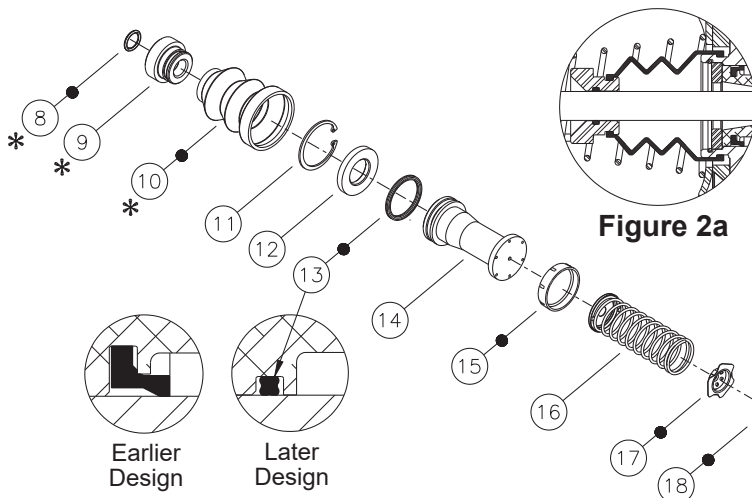

**Figure 2a**

- Items included in Repair Kit
- \* Not used in all models

## FIGURE 2

## MASTER CYLINDER ASSEMBLY

(Refer to Figure 2)

LUBRICATE ALL RUBBER COMPONENTS FROM REPAIR KIT WITH CLEAN TYPE FLUID USED IN THE SYSTEM.

1. Clean all parts thoroughly before assembly.
2. Carefully install new quad ring or new cup (13) on piston (14). **NOTE: Earlier models use a cup and later models use a quad ring. NOTE: Be careful not to scratch or mar piston (14).**
3. Carefully install new seat (18) in housing bore. Be sure seat (18) is bottomed out in housing bore.
4. Install new check valve (17) on the end of spring (16) and install into housing bore.
5. Install new cup (15) and piston (14) into housing bore. Note direction of cup (15) and piston (14).
6. Install spacer (12) and new retaining ring (11) in housing bore.
7. Carefully install new o-ring (8) in guide (9). **NOTE: Not all models use o-ring (8) or guide (9).**
8. Install boot (10) on guide (9) and on master cylinder (5). See Figure 2a. **NOTE: Not all models use guide (9) or boot (10).**
9. Install new gasket (7) and filler plug (6) on housing. **NOTE: Before installing filler plug (6) be sure the filler plug breather hole is free of all contaminants. Use air pressure to clean and dry this hole.**
10. If mounting bracket was removed from the master cylinder, reattach using four screws (1), lock washers (3), and nuts (4). Torque nuts (4) 29.8-36.6 N·m (22-27 lb·ft). **NOTE: Model number 03-460-436 will require these items to be reinstalled. Lightly grease the end of the push rod. See Figure 2b.**
11. Refer to CONNECTING AIR CHAMBER AND MASTER CYLINDER on front page.

