

PEDAL ACTUATED Reverse Modulating Brake Valve



Service Instructions

TABLE 1 (Specifications)

Model Number	Repair Kit Number	Brake Pressure Setting	
		bar	(PSI)
03-460-310	407 101 900 2	20.7 ± 0.69	(300 ± 10)
03-460-312	407 101 900 2	27.6 ± 0.69	(400 ± 10)
03-460-314	02-400-205	12.9 ± 0.83	(187 ± 12)
03-460-318	02-400-205	41.4 ± 5.2	(600 ± 75)
03-460-322	02-400-205	20.7 ± 1.7	(300 ± 25)
* 20-100-420	02-400-205	13.8 ± 1.4	(200 ± 20)
* 20-100-446	02-400-205	19.0 ± 1.4	(275 ± 20)
* 20-100-520	407 101 900 2	20.7 ± 0.69	(300 ± 10)
* 20-100-878	407 101 900 2	22.4 ± 2.1	(325 ± 30)
* 20-100-879	02-400-259	86.2 ± 5.2	(1250 ± 75)
* 20-100-905	02-400-205	19.0 ± 1.4	(275 ± 20)

* Valve only, no pedal

NOTE: If your product number is not listed, contact ZF Off-Highway Solutions Minnesota Inc. for information.

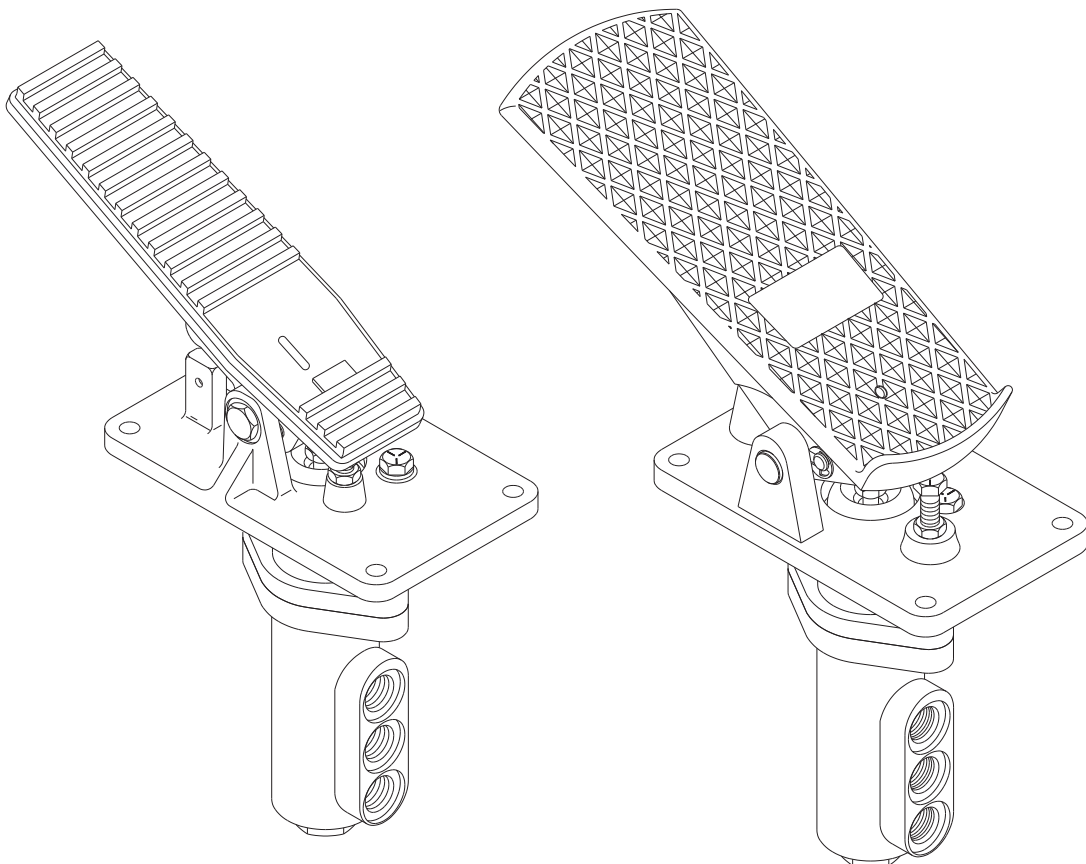

FIGURE 1

DISASSEMBLY

(Refer to Figures 2 and 3)

1. Depress pedal (1) and remove pedal stop screw (11) and jam nut (12) from base (8). Also loosen jam nut (13) for later removal of clevis (5).
2. Remove cap screws (6) and lock washers (7) from base (8).
3. Remove e-rings (9) from pins (10). Remove pins (10).
NOTE: Some models use threaded studs (10), Figure 3, in place of pins (10) and e-rings (9).
4. Remove set screw (2) from pedal (1). Remove e-rings (4) from both ends of pin (3). **NOTE: Not all models use e-rings (4).**
5. Separate pedal and base by removing pin (3) through clearance hole in pedal (1). Remove pedal (1) and base (8).
6. Temporarily insert pin (3) into clevis (5) and record distance from top of pin (3) to mounting flange of housing (17). This measurement will be necessary for reassembly purposes. **NOTE: Apply slight downward force on clevis (5) while taking measurement to assure that rod (22) is in contact with piston (23).**
7. Remove clevis (5) and jam nut (13) from rod (22).
8. Separate housings (17 & 32) by removing cap screws (15) and lock washers (16).
9. Remove rod (22), piston (21), spring (20), spring (19), and washer (18) from housing (17). **NOTE: Not all models use spring (19) or washer (18).**
10. Remove boot (14) from housing (17).
11. Remove piston (23), shim(s) (24) and spring (25) from housing (32) bore. Note number of shims being removed for reassembly purposes.
12. Remove o-ring (26) from housing (32) bore. **NOTE: Be careful not to scratch or mar housing bore.**
13. Remove retaining ring (27) from housing (32) bore. **NOTE: Be careful not to scratch or mar housing bore.**
14. Remove washer (28) from housing (32) bore.
15. Remove piston (29) from housing (32) bore. Remove cup (30) from piston (29). Note direction of cup.
16. Remove spring (31) from housing (32) bore.
17. Remove plug (45) from housing (32).
18. Remove o-ring (44), cup (42), back-up ring (43), washer (41), spring (40), and guide (39) from plug (45).
19. Remove cage (35) from housing (32) bore.
20. Remove valve assembly (34) from housing (32) bore.
21. Remove o-ring (33) from valve assembly (34).
22. Remove plug (38) and ball (36) from housing (32). Remove o-ring (37) from plug (38).
23. Install new o-ring (44) on plug (45).
24. Install new back-up ring (43) and new cup (42) in plug (45). Note order of back-up ring and cup.
25. Install washer (41), spring (40), and guide (39) in plug (45). Install plug (45) in housing (32) and torque 54.3-67.8 N·m (40-50 lb·ft).
26. Install new cup (30) on piston (29). Note direction of cup (30).
27. Install spring (31) and piston (29) in housing (32) bore. Note direction of piston (29).
28. Install washer (28) and retaining ring (27) in housing (32) bore. **NOTE: Be careful not to scratch or mar housing bore.**
29. Install new o-ring (26) in housing (32) bore.
30. Install spring (25), shim(s) (24), and piston (23) in housing (32) bore. Be sure to install the same number of shim(s) as were removed during disassembly.
31. Lightly coat inside bore of housing (17) with graphite based grease and install new boot (14) on housing (17).
32. Apply graphite based grease sparingly to piston (21) in chamfered area where rod (22) makes contact.
33. Install rod (22), piston (21), spring (20), spring (19), and washer (18) into housing (17). **NOTE: Not all models use spring (19) or washer (18).**
34. Attach housings (17 & 32) using cap screws (15) and lock washers (16). Torque 29.8-36.6 N·m (22-27 lb·ft).
35. Install jam nut (13) and clevis (5) on end of rod (22). Adjust clevis (5) to the distance recorded during disassembly.

LUBRICATE ALL BUSHINGS AND PINS WITH GRAPHITE BASED GREASE BEFORE ASSEMBLING THE PEDAL AND BASE.

18. Place base (8) on housing (17) mounting flange. Position pedal (1) and insert pin (3) through clearance hole in pedal and into clevis (5). **NOTE: Position pin so that flat area is aligned with set screw hole in pedal.**
19. Install set screw (2) in pedal (1) and torque 10.9 N·m (8 lb·ft). Install new e-rings (4) on each end of pin (3). **NOTE: Not all models use e-rings (4).**
20. Insert pins (10) through base (8) and into pedal (1). Install new e-rings (9) on pins (10). **NOTE: Some models use threaded studs (10), Figure 3, in place of pins (10) and e-rings (9).**
21. Attach base (8) to valve assembly using cap screws (6) and lock washers (7). Torque 29.8-36.6 N·m (22-27 lb·ft).
22. Fully depress pedal (1) and tighten jam nut (13) against clevis (5).
23. Install pedal stop screw (11) and jam nut (12).
NOTE: With pedal in the released position, adjust pedal stop screw and jam nut so there is 0.38-0.76 mm (0.015-0.030 in) clearance between the pedal and top of pedal stop screw.

ASSEMBLY

(Refer to Figures 2 and 3)

CLEAN AND INSPECT ALL PARTS FOR WEAR.
LUBRICATE ALL RUBBER COMPONENTS FROM REPAIR KIT WITH CLEAN SYSTEM FLUID.

1. Install new o-ring (37) on plug (38).
2. Install new ball (36) and plug (38) in housing (32). Torque plug (38) 7.4-8.5 N·m (65-75 lb·in).
3. Install new o-ring (33) on valve assembly (34) and install in housing (32) bore. Note direction of valve assembly. **NOTE: Be sure valve assembly seat is fully seated into housing.**
4. Install new cage (35) into housing (32) bore.

● Items included in Repair Kits
 * Not used in all models

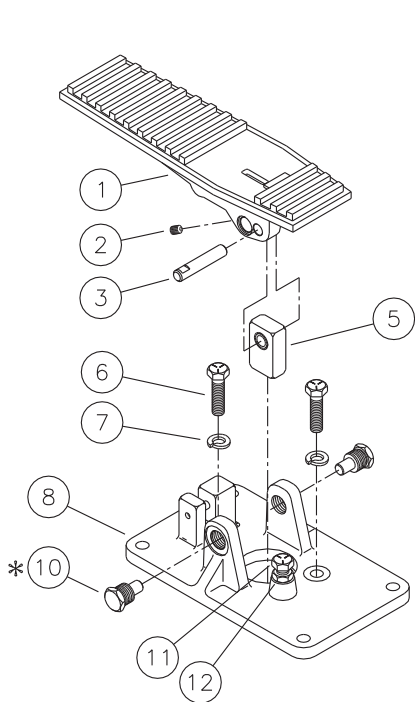

FIGURE 3

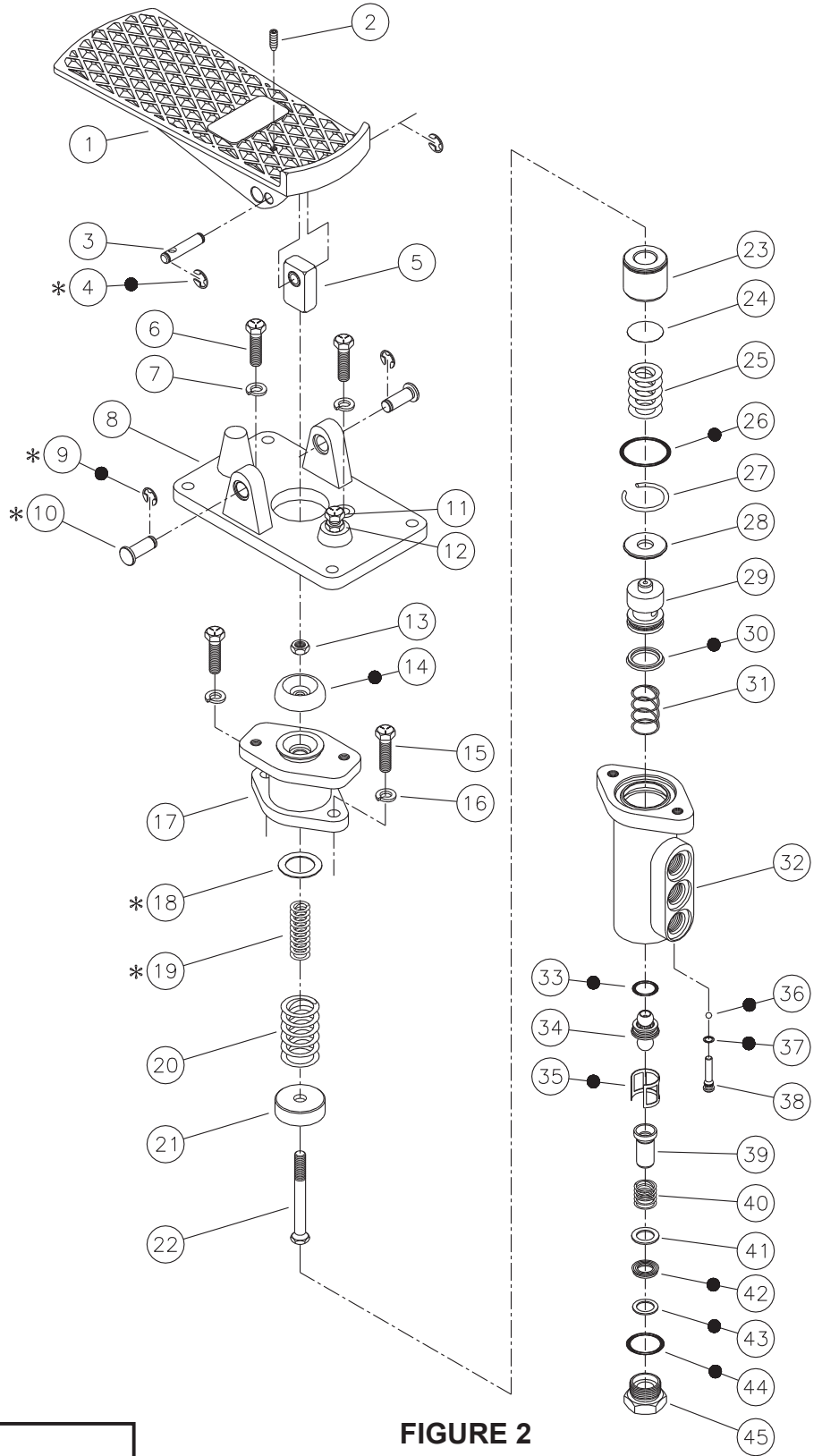

FIGURE 2

NOTE
 After service, the valve must develop the pressure indicated in the specifications, TABLE 1. Shim(s) (24) may be added or removed to obtain the correct pressure setting.

This publication is not subject to any update service. Information contained in this publication was in effect at the time the publication was approved for printing and is subject to change without notice or liability. ZF Off-Highway Solutions Minnesota Inc. reserves the right to revise the information presented or to discontinue the production of parts described at any time.

