

TITLE MULTIPLE DISC BRAKE MODULE		PART NUMBER 21-100-106
REV.	NPR OR ECO NO.	DATE
D	ECO S-1324	03/17/99

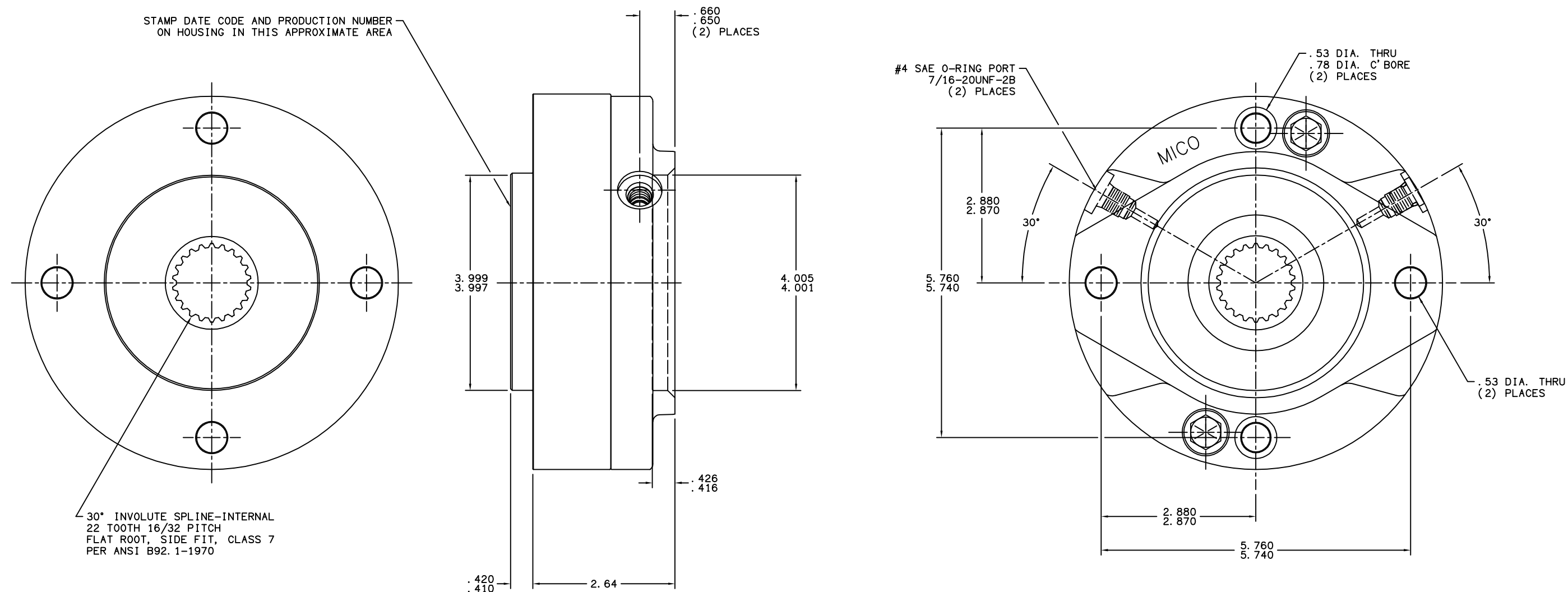

NOTES:

- 1) LINING REPAIR KIT P/N 20-060-103
- 2) O-RING REPAIR KIT P/N 02-500-215
- 3) SPRING REPAIR KIT P/N 12-501-375

SPECIFICATIONS:

TYPE: WET MULTIPLE DISC BRAKE, SPRING APPLY, HYDRAULIC RELEASE

MAXIMUM SPEED: 4,000 RPM SHAFT SPEED CAPABILITY SPECIFIED IS FOR BRAKE IN RELEASED CONDITION. ENERGY ABSORPTION DURING APPLY CYCLE MUST BE CAREFULLY EXAMINED FOR EACH APPLICATION.

RELEASE PRESSURE: 150 PSI INITIAL, 175 PSI FULL, 3,000 PSI MAX.

TORQUE RATING: 1,800 LB-IN STATIC (BREAKAWAY)

VOLUME OF OIL REQUIRED TO RELEASE BRAKE: 0.5 IN.³ MIN., 0.9 IN.³ MAX.

APPROXIMATE WEIGHT: 19 LBS.

FOR USE WITH MINERAL BASE HYDRAULIC OIL ONLY.

CAUTION!

IF HYDROSTATIC BENCH TESTING IS PERFORMED ON BRAKE ASSEMBLY, RELEASE PRESSURE SHOULD NOT EXCEED 400 P.S.I. UNLESS FOUR ADDITIONAL BOLTS (GRADE 5 OR BETTER) ARE USED FOR SUPPLEMENTAL CLAMPING.

MICO, INC. CLAIMS PROPRIETARY RIGHTS TO THE MATERIAL DISCLOSED IN THIS DOCUMENT. THIS DOCUMENT IS PROVIDED IN CONFIDENCE AND MAY NOT BE REPRODUCED OR DISCLOSED WITHOUT WRITTEN PERMISSION FROM MICO, INC. COPYRIGHT MICO, INC. ALL RIGHTS RESERVED.

mico
North Mankato, Minnesota U.S.A.

SCALE 1:2	PART NUMBER 21-100-106	REV.
X NO.	CUSTOMER COPY	D
DRAWN ETM		
REVISED G.J.		
DATE 03/17/99	CHECKED	APPROVED ENG.