

CAUTION:

OILS CONTAINING SLIPPERY OR ANTI-WEAR ADDITIVES, SUCH AS GRAPHITE OR MOLYBDENUM DISULFIDE, OR EXTREME PRESS. (E. P.) TYPE LUBRICANTS SHOULD NOT BE USED, THESE LUBRICANTS MAY ALLOW THE BRAKE TO SLIP AT TORQUE LEVELS BELOW THE RATED VALUES.

PART NUMBER
13-602-014
NPI OR ECN NO.
ECO S-1703

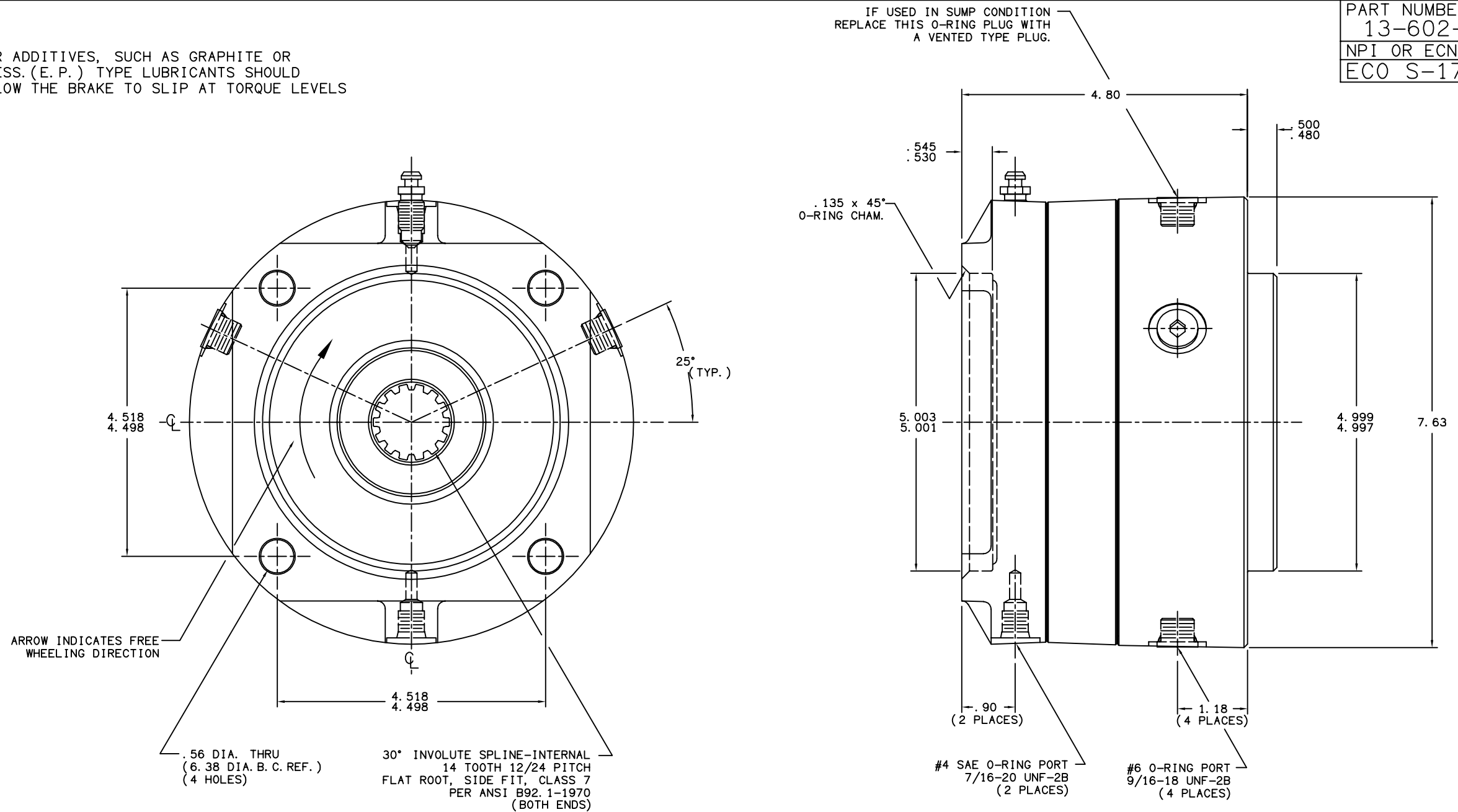

NOTES:

- 1.) LINING REPAIR KIT P/N 12-501-214
- 2.) BEARING REPAIR KIT P/N 12-501-094
- 3.) O-RING REPAIR KIT P/N 12-501-295
- 4.) SPRING REPAIR KIT P/N 12-501-294

SPECIFICATIONS:

TYPE:	WET MULTIPLE DISC BRAKE, (WITH ONE WAY CLUTCH) SPRING APPLY, HYDRAULIC RELEASE
TORQUE RATING:	7,500 LB-IN STATIC (BREAKAWAY) AT 0 PSI BACK PRESSURE
RELEASE PRESSURE:	250 PSI INITIAL, 330 PSI FULL
MAXIMUM OPERATING PRESSURE:	3,000 PSI
MAXIMUM SPEED:	NON-FREE WHEELING DIRECTION: (FLOW THRU) 4,000 RPM (SUMP) 3,000 RPM FREE WHEELING DIRECTION: (FLOW THRU & SUMP) 4,000 RPM
LINING MATERIAL:	METALLIC GRAPHITIC
APPROXIMATE WEIGHT:	42 LBS.

COOLING OIL RECOMMENDATIONS:

OIL TYPE: MINERAL BASE HYDRAULIC OIL SUCH AS MOBIL DTE 24, CITGO A/W 32 OR EQUIVALENT

FLOW THRU CAPACITY: 1.0 - 7.0 GPM

MAXIMUM CASE PRESSURE: 30 PSI

SUMP OIL VOLUME: 6 FL. OZ.

BRAKE IS DESIGNED FOR HORIZONTAL USE ONLY



TITLE WINCH BRAKE 3CWC-041475-CCC			
SCALE 1:2	CHECKED LH 08/29/03	PART NUMBER 13-602-014	REV D
DRN g. J. 05/29/03	APP ENG GAA 08/29/03	CUSTOMER COPY	

COMPONENT AND SYSTEM RECOMMENDATIONS MADE BY MICO, INC. ARE BASED ON INFORMATION SUPPLIED BY POTENTIAL USER AND/OR SYSTEM DESIGNER. THE POTENTIAL USER AND/OR DESIGNER MUST MAKE FINAL ACCEPTANCE AND APPROVAL OF COMPONENTS AND SYSTEM AFTER TESTING PERFORMANCE ON AN ACTUAL APPLICATION FOR WHICH SYSTEM WAS DESIGNED.

MICO, INC. CLAIMS PROPRIETARY RIGHTS TO THE MATERIAL DISCLOSED IN THIS DOCUMENT. THIS DOCUMENT IS PROVIDED IN CONFIDENCE AND MAY NOT BE REPRODUCED OR DISCLOSED WITHOUT WRITTEN PERMISSION FROM MICO, INC. COPYRIGHT MICO, INC. ALL RIGHTS RESERVED.