

REV.	NPR OR ECO NO.	DATE
E	ECO S-1703	05/27/03

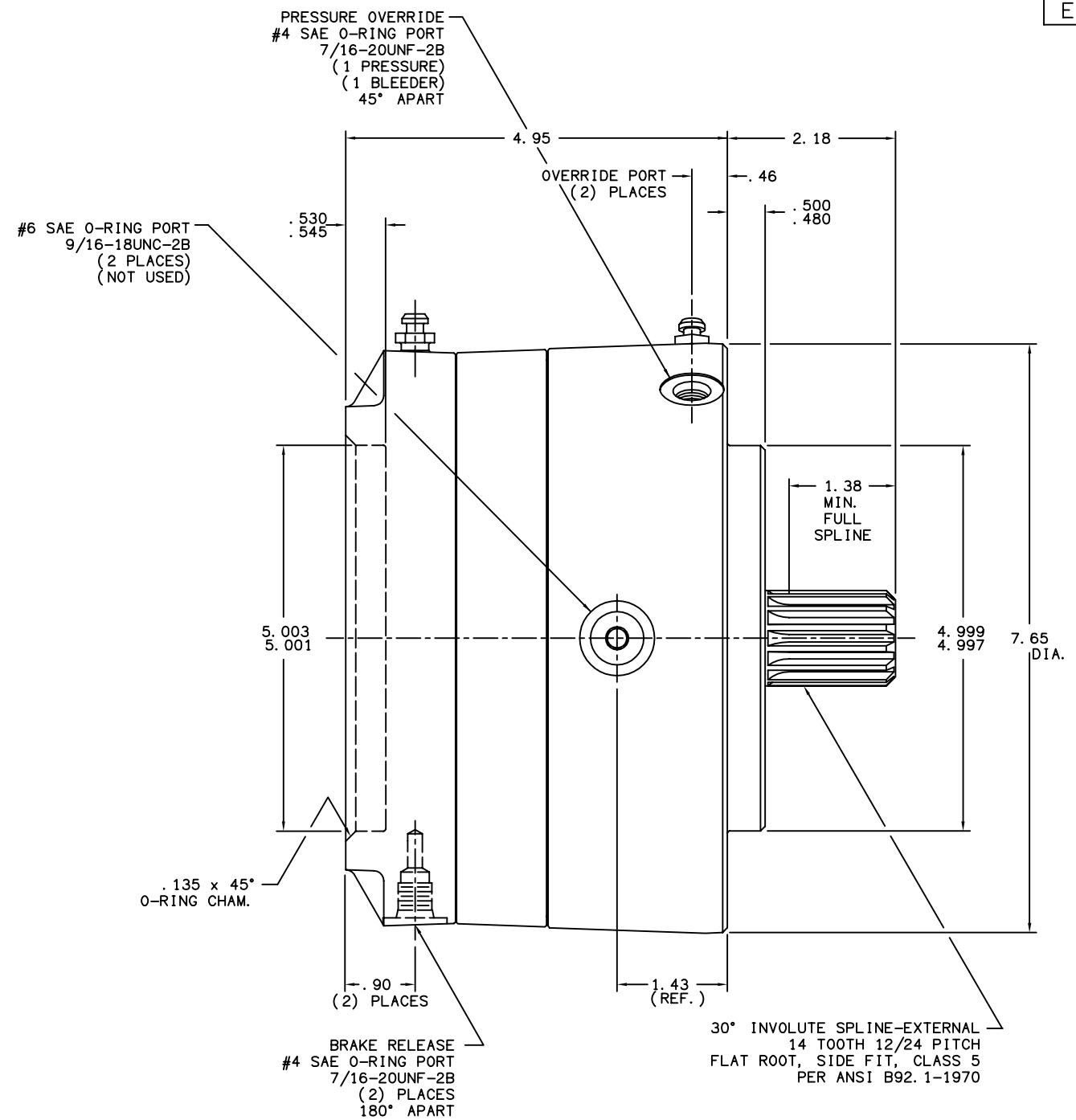
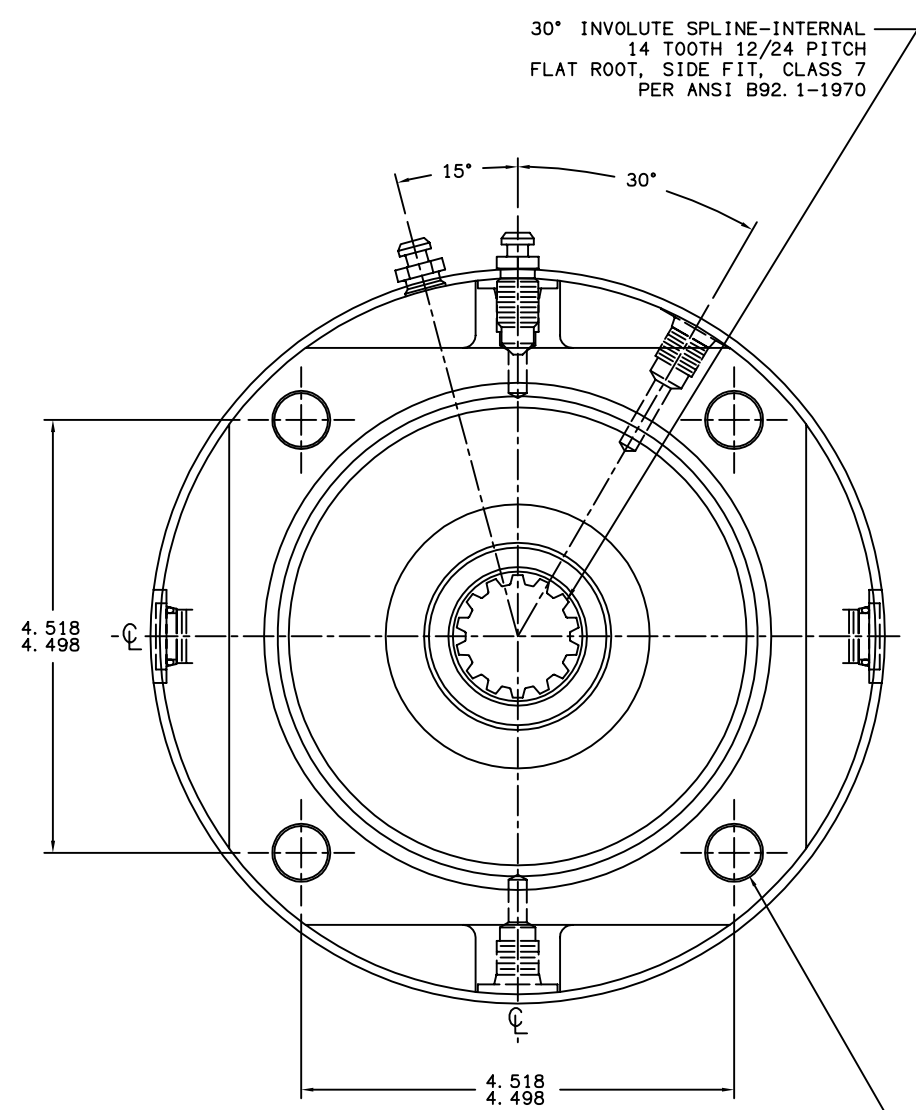

NOTES:

- 1) LINING REPAIR KIT P/N 12-501-320
- 2) BEARING REPAIR KIT P/N 12-501-322
- 3) O-RING REPAIR KIT P/N 12-501-323
- 4) SPRING REPAIR KIT P/N 12-501-324

SPECIFICATIONS:

TYPE: DRY MULTIPLE DISC BRAKE, SPRING APPLY, HYDRAULIC RELEASE. (WITH PRESSURE OVERRIDE)

FAILSAFE SECTION:
 TORQUE RATING: 5,500 LB-IN STATIC (BREAKAWAY) AT 0 PSI BACK PRESSURE
 RELEASE PRESSURE: 160 PSI INITIAL, 220 PSI FULL, 3,000 PSI MAX. CONTINUOUS

SERVICE OVERRIDE SECTION:
 TORQUE RATING: 9,400 LB-IN @ 1,000 PSI
 MAXIMUM INPUT PRESSURE: 1,000 PSI

MAXIMUM SPEED: 4,000 RPM, HOWEVER, MAXIMUM SPEED AT TIME OF SERVICE APPLY IS DEPENDENT ON PRODUCT APPLICATION.

LINING MATERIAL: METALLIC GRAPHITIC

APPROXIMATE WEIGHT: 44 LBS.

FOR USE WITH MINERAL BASE HYDRAULIC OIL ONLY.

.565 DIA. THRU
(ON 6.375 DIA. B.C., REF.)
(4) PLACES

MICO North Mankato, Minnesota U.S.A.		
SCALE 1:2	PART NUMBER	REV.
X NO.	13-597-002	E
DRAWN G. J.	CUSTOMER COPY	
REVISED G. J.		
DATE 10/1/98	CHECKED LH 08/29/03	APPROVED ENGBAA 08/29/03

MICO, INC. CLAIMS PROPRIETARY RIGHTS TO THE MATERIAL DISCLOSED IN THIS DOCUMENT. THIS DOCUMENT IS PROVIDED IN CONFIDENCE AND MAY NOT BE REPRODUCED OR DISCLOSED WITHOUT WRITTEN PERMISSION FROM MICO, INC. COPYRIGHT MICO, INC. ALL RIGHTS RESERVED.