

SECTION E-E

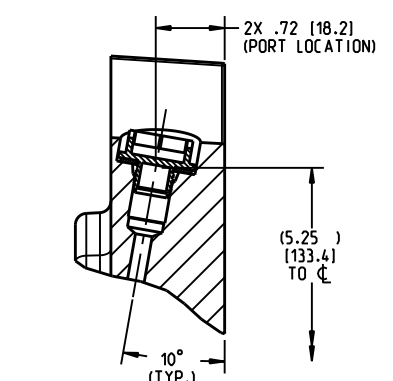

SECTION C-C

- NOTES:**
1. USE MINERAL BASE HYDRAULIC OIL ONLY FOR BRAKE RELEASE
 2. DIMENSIONS MAY VARY BETWEEN UNITS AND ARE FOR REFERENCE PURPOSES ONLY
MILLIMETER VALUES MAY NOT BE AN EXACT CONVERSION OF INCH VALUES.
 3. LINING REPAIR KIT P/N 12-501-306
 4. BEARING REPAIR KIT P/N 12-501-250
 5. O-RING REPAIR KIT P/N 12-501-249
 6. SPRING REPAIR KIT P/N 12-501-251

SPECIFICATIONS:

TYPE:	DRY MULTIPLE DISC BRAKE, SPRING APPLY, HYDRAULIC RELEASE
TORQUE RATING:	16,000 LBIN STATIC (BREAKAWAY) AT 0 PSI BACK PRESSURE
RELEASE PRESSURE:	210 PSI INITIAL, 300 PSI FULL
MAXIMUM OPERATING PRESSURE:	3,000 PSI
MAXIMUM SPEED:	3,900 RPM
LINING MATERIAL:	SINTERED BRONZE
APPROXIMATE WEIGHT:	60 LB

INCH
[MILLIMETER]

COMPONENT AND SYSTEM RECOMMENDATIONS MADE BY MICO, INC ARE BASED ON INFORMATION SUPPLIED BY POTENTIAL USER AND/OR SYSTEM DESIGNER. THE POTENTIAL USER AND/OR DESIGNER MUST MAKE FINAL ACCEPTANCE AND APPROVAL OF COMPONENTS AND SYSTEM AFTER TESTING PERFORMANCE ON AN ACTUAL APPLICATION FOR WHICH SYSTEM WAS DESIGNED.		MICO, INC CLAIMS PROPRIETARY RIGHTS TO THE MATERIAL DISCLOSED IN THIS DOCUMENT. THIS DOCUMENT IS PROVIDED IN CONFIDENCE AND MAY NOT BE REPRODUCED OR DISCLOSED WITHOUT WRITTEN PERMISSION FROM MICO, INC. COPYRIGHT MICO, INC. ALL RIGHTS RESERVED.	
SCALE 0.500	TITLE MULTIPLE DISC BRAKE		
DWN RGS1 2010-05-31	APVD PROD ENGRG PJS 2010-06-02	SIZE B	DRAWING NUMBER 13-552-114
X NO 08-2229	APVD ENGRG RV 2010-06-04	REV A	CUSTOMER COPY

