

TITLE MULTIPLE DISC BRAKE 3D-131516-E		PART NUMBER 13-552-090
REV.	NPR OR ECO NO.	DATE
B	ECO S-1731	02/02/04

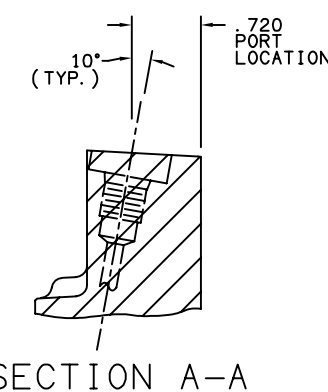
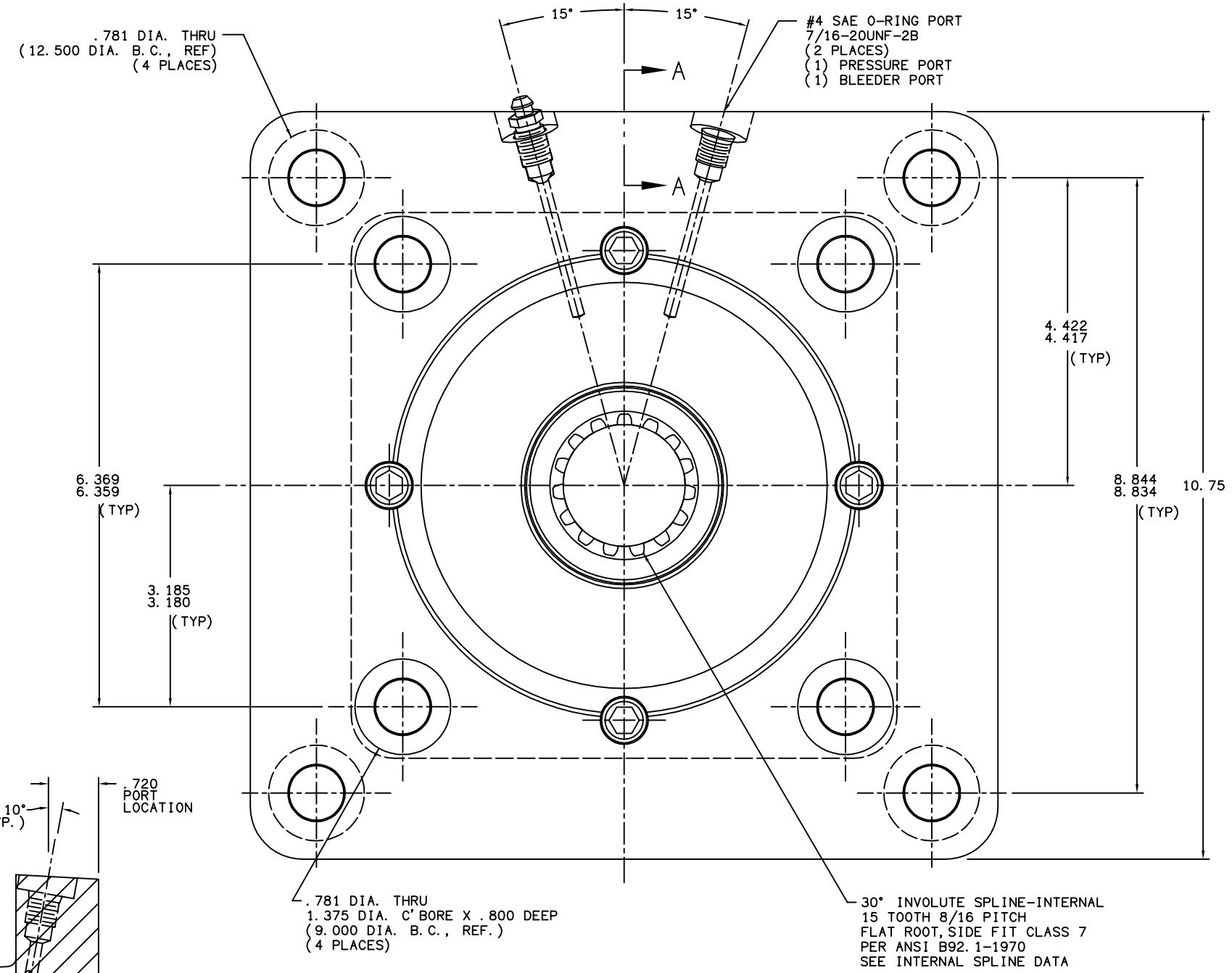
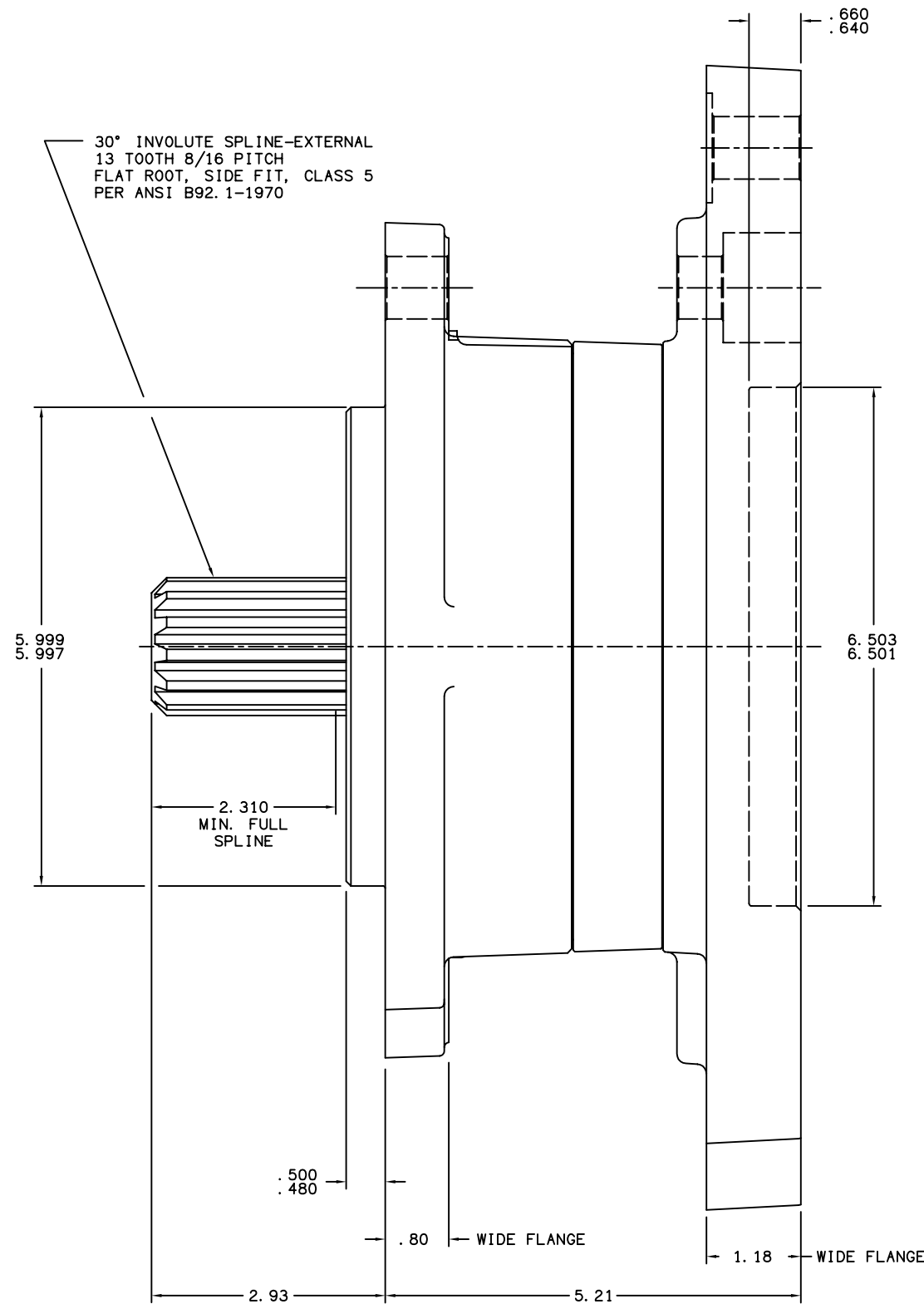

**SPECIFICATIONS:**

<b>TYPE:</b>	DRY MULTIPLE DISC BRAKE, SPRING APPLY, HYDRAULIC RELEASE
<b>TORQUE RATING:</b>	16,000 LB-IN STATIC (BREAKAWAY) AT 0 PSI BACK PRESSURE
<b>RELEASE PRESSURE:</b>	210 PSI INITIAL, 300 PSI FULL
<b>MAXIMUM OPERATING PRESSURE:</b>	3,000 PSI
<b>MAXIMUM SPEED:</b>	3,900 RPM
<b>APPROXIMATE WEIGHT:</b>	60 LBS.
FOR USE WITH MINERAL BASE HYDRAULIC OIL ONLY	

**NOTES:**

- 1) O-RING REPAIR KIT P/N 12-501-249
- 2) BEARING REPAIR KIT P/N 12-501-250
- 3) SPRING REPAIR KIT P/N 12-501-251
- 4) LINING REPAIR KIT P/N 12-501-306

MICO, INC. CLAIMS PROPRIETARY RIGHTS TO THE MATERIAL DISCLOSED IN THIS DOCUMENT. THIS DOCUMENT IS PROVIDED IN CONFIDENCE AND MAY NOT BE REPRODUCED OR DISCLOSED WITHOUT WRITTEN PERMISSION FROM MICO, INC. COPYRIGHT MICO, INC. ALL RIGHTS RESERVED.

<b>mico</b>		
North Mankato, Minnesota U.S.A.		
SCALE 1:2	PART NUMBER	REV.
X NO.	13-552-090	B
DRAWN G. J.	CUSTOMER COPY	
REVISED LH	DATE	CHECKED
	10/09/02	APPROVED ENG.