

DRAWING NUMBER
13-552-088
NPI OR ECN NO
ECN000529

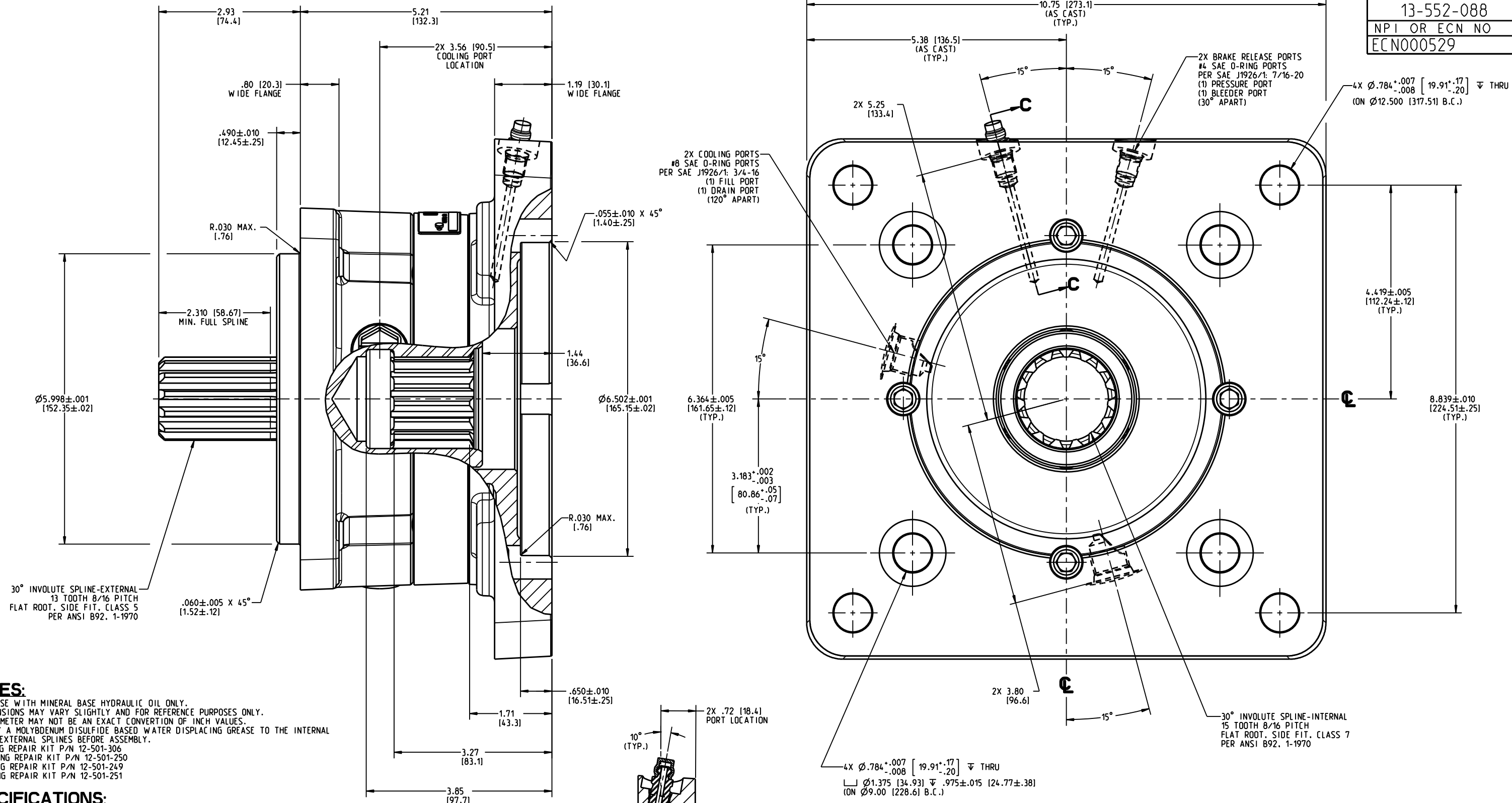

- NOTES:**
1. FOR USE WITH MINERAL BASE HYDRAULIC OIL ONLY.
 2. DIMENSIONS MAY VARY SLIGHTLY AND FOR REFERENCE PURPOSES ONLY. MILLIMETER MAY NOT BE AN EXACT CONVERSION OF INCH VALUES.
 3. APPLY A MOLYBDENUM DISULFIDE BASED WATER DISPLACING GREASE TO THE INTERNAL AND EXTERNAL SPLINES BEFORE ASSEMBLY.
 4. LINING REPAIR KIT P/N 12-501-306
 5. BEARING REPAIR KIT P/N 12-501-250
 6. O-RING REPAIR KIT P/N 12-501-249
 7. SPRING REPAIR KIT P/N 12-501-251

SPECIFICATIONS:

TYPE: WET MULTIPLE DISC BRAKE, SPRING APPLY, HYDRAULIC RELEASE

TORQUE RATING: 13,000 LBIN STATIC (BREAKAWAY) AT 0 PSI BACK PRESSURE
ACTUAL TORQUE MAY VARY BY UP TO 10% DUE TO MANUFACTURING TOLERANCES.

RELEASE PRESSURE: 270 PSI INITIAL, 360 PSI FULL

MAXIMUM CASE PRESSURE: 10 PSI

MAXIMUM OPERATING PRESSURE: 3,000 PSI

MAXIMUM SPEED: 3,900 RPM

LINING MATERIAL: SINTERED BRONZE

APPROXIMATE WEIGHT: 60 LB

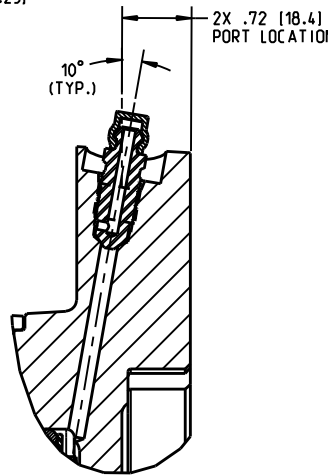

INCH
[MILLIMETER]

COMPONENT AND SYSTEM RECOMMENDATIONS MADE BY MICO, INC ARE BASED ON INFORMATION SUPPLIED BY POTENTIAL USER AND/OR SYSTEM DESIGNER. THE POTENTIAL USER AND/OR DESIGNER MUST MAKE FINAL ACCEPTANCE AND APPROVAL OF COMPONENTS AND SYSTEM AFTER TESTING PERFORMANCE ON AN ACTUAL APPLICATION FOR WHICH SYSTEM WAS DESIGNED.		MICO, INC CLAIMS PROPRIETARY RIGHTS TO THE MATERIAL DISCLOSED IN THIS DOCUMENT. THIS DOCUMENT IS PROVIDED IN CONFIDENCE AND MAY NOT BE REPRODUCED OR DISCLOSED WITHOUT WRITTEN PERMISSION FROM MICO, INC. COPYRIGHT MICO, INC. ALL RIGHTS RESERVED.	
SCALE 0.500	TITLE 3D-131520-EZ MULTIPLE DISC BRAKE	SIZE B	DRAWING NUMBER 13-552-088
DWN RGBSI 2013-08-01	APVD PROD ENGRG PJS 2013-08-21	REV C	CUSTOMER COPY
X NO X6757	APVD ENGRG BLF 2013-08-19		

