

DRAWING NUMBER
13-552-056
NPI OR ECN NO
ECN000526

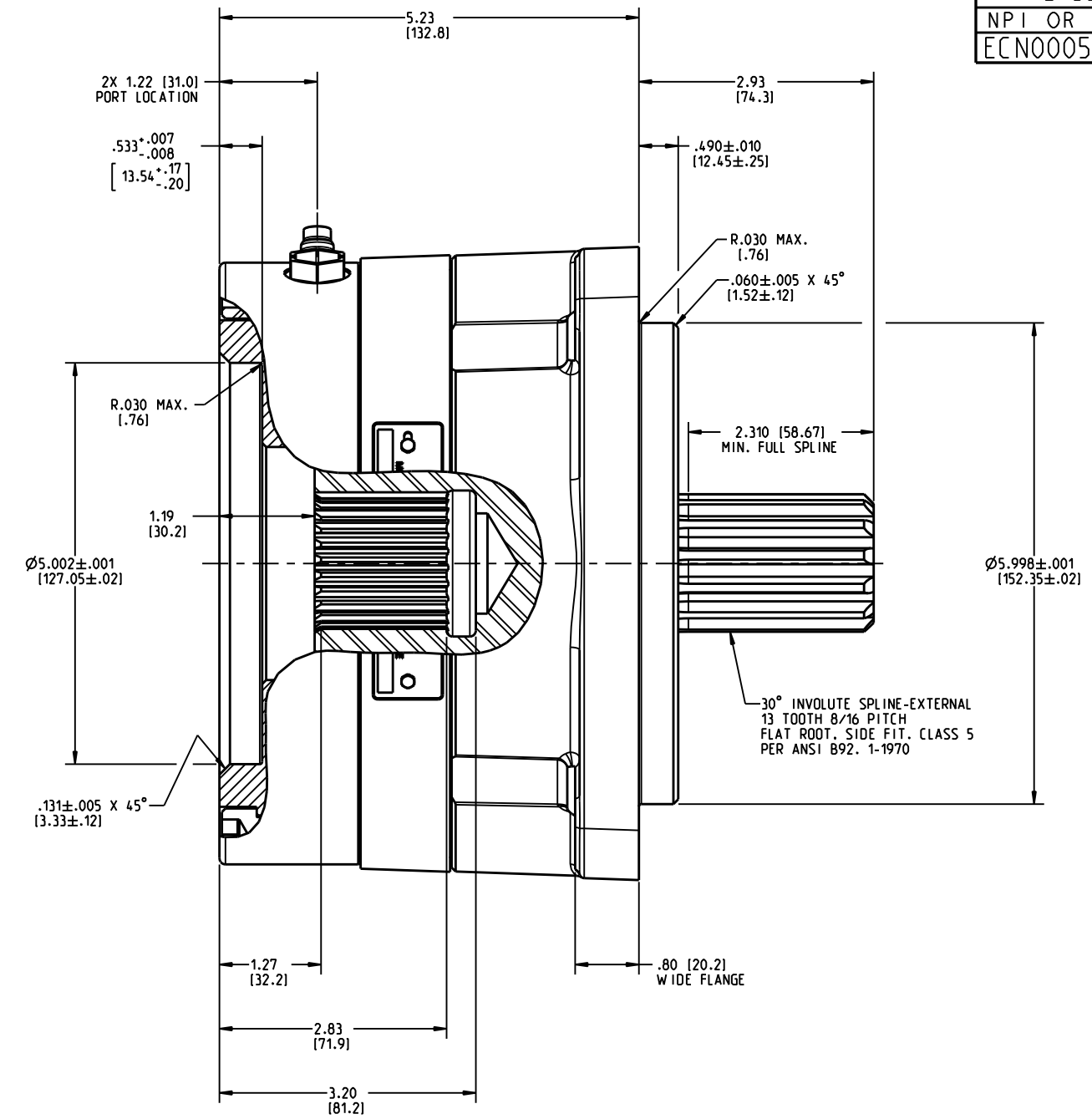
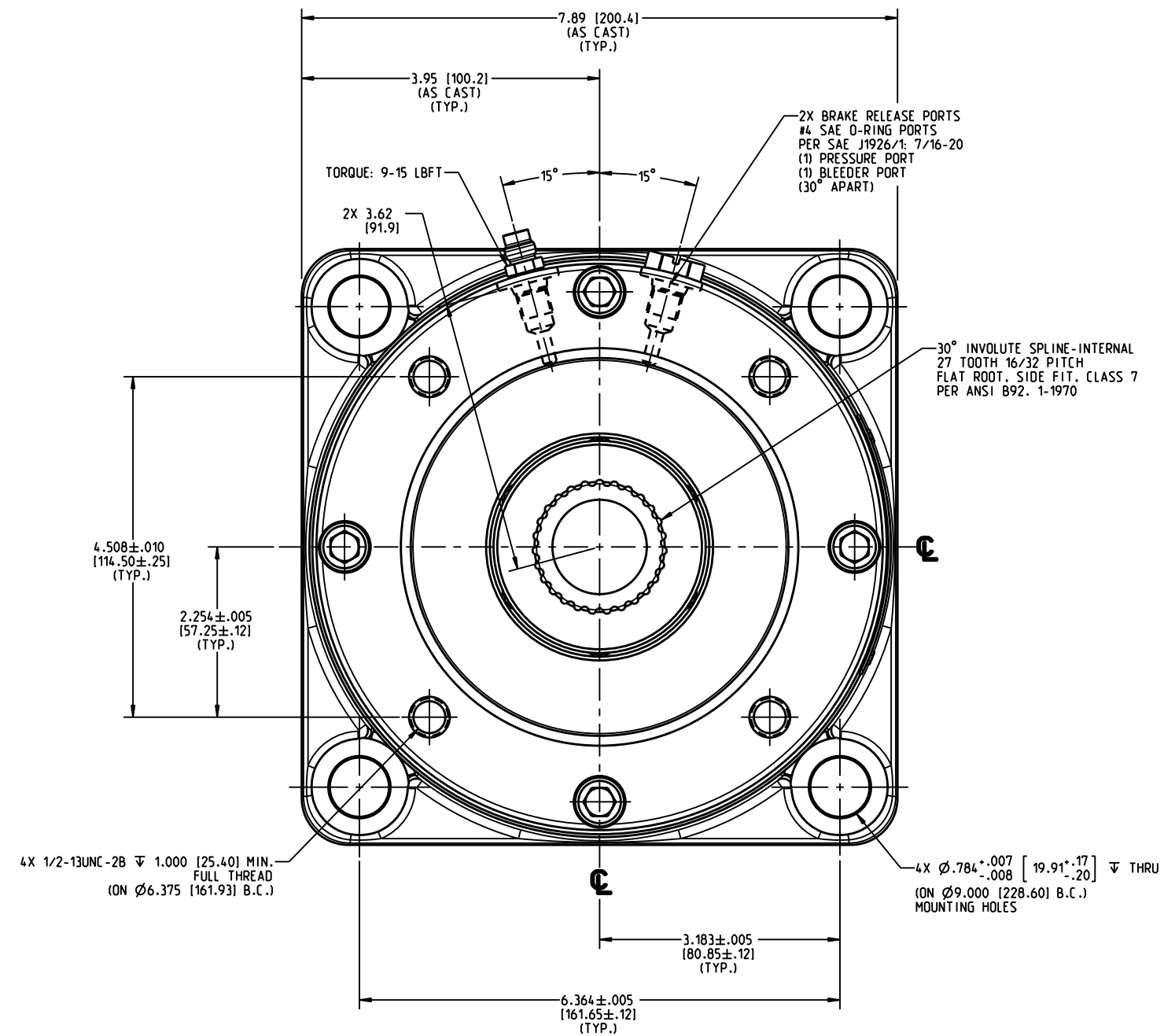

NOTES:

- FOR USE WITH MINERAL BASE HYDRAULIC OIL ONLY.
- DIMENSIONS MAY VARY SLIGHTLY AND FOR REFERENCE PURPOSES ONLY. MILLIMETER MAY NOT BE AN EXACT CONVERSION OF INCH VALUES.
- APPLY A MOLYBDENUM DISULFIDE BASED WATER DISPLACING GREASE TO THE INTERNAL AND EXTERNAL SPLINES BEFORE ASSEMBLY.
- LINING REPAIR KIT P/N 12-501-306
- BEARING REPAIR KIT P/N 12-501-250
- O-RING REPAIR KIT P/N 12-501-249
- SPRING REPAIR KIT P/N 12-501-251

SPECIFICATIONS:

TYPE:	DRY MULTIPLE DISC BRAKE, SPRING APPLY, HYDRAULIC RELEASE
TORQUE RATING:	10,000 LBIN STATIC (BREAKAWAY) AT 0 PSI BACK PRESSURE ACTUAL TORQUE MAY VARY BY UP TO 10% DUE TO MANUFACTURING TOLERANCES.
RELEASE PRESSURE:	150 PSI INITIAL, 200 PSI FULL
MAXIMUM OPERATING PRESSURE:	3,000 PSI
MAXIMUM SPEED:	3,900 RPM
LINING MATERIAL:	SINTERED BRONZE
APPROXIMATE WEIGHT:	50 LB

INCH
[MILLIMETER]

MICO North Mankato, Minnesota USA				
SCALE 0.500	TITLE 3D-132710-C MULTIPLE DISC BRAKE			
DWN RGS1 2013-07-01	APVD PROD ENGRG PJS 2013-07-24	SIZE B	DRAWING NUMBER 13-552-056	REV F
X NO	APVD ENGRG CL 2013-07-03	B	CUSTOMER COPY	0

COMPONENT AND SYSTEM RECOMMENDATIONS MADE BY MICO, INC ARE BASED ON INFORMATION SUPPLIED BY POTENTIAL USER AND/OR SYSTEM DESIGNER. THE POTENTIAL USER AND/OR DESIGNER MUST MAKE FINAL ACCEPTANCE AND APPROVAL OF COMPONENTS AND SYSTEM AFTER TESTING PERFORMANCE ON AN ACTUAL APPLICATION FOR WHICH SYSTEM WAS DESIGNED.

MICO, INC CLAIMS PROPRIETARY RIGHTS TO THE MATERIAL DISCLOSED IN THIS DOCUMENT. THIS DOCUMENT IS PROVIDED IN CONFIDENCE AND MAY NOT BE REPRODUCED OR DISCLOSED WITHOUT WRITTEN PERMISSION FROM MICO, INC. COPYRIGHT MICO, INC. ALL RIGHTS RESERVED.