

TITLE MULTIPLE DISC BRAKE 3D-131380-E		PART NUMBER 13-552-044	
REV.	NPR OR ECO NO.	DATE	
E	ECO S-1731	01/20/04	

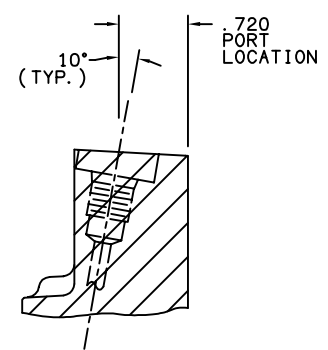
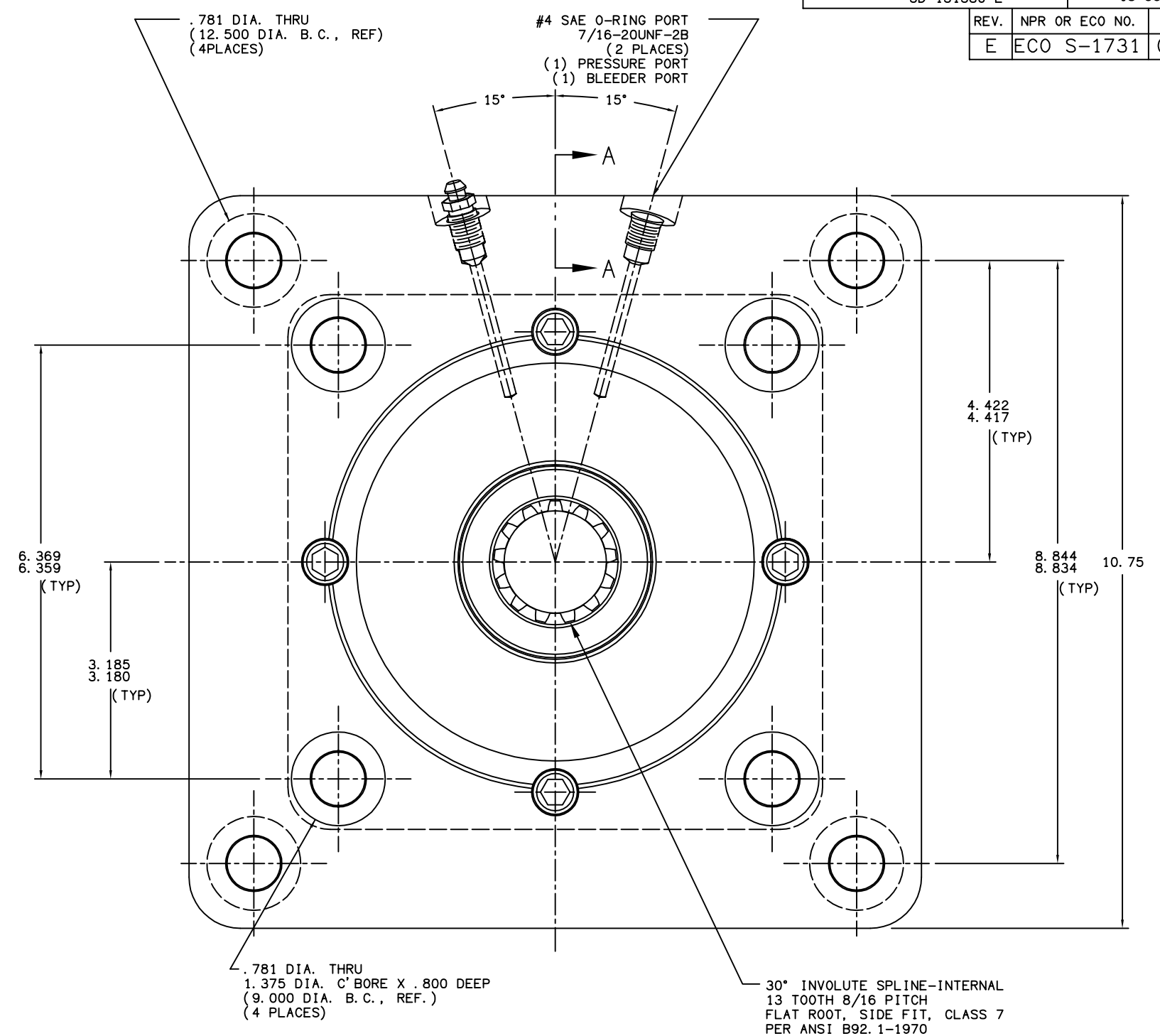
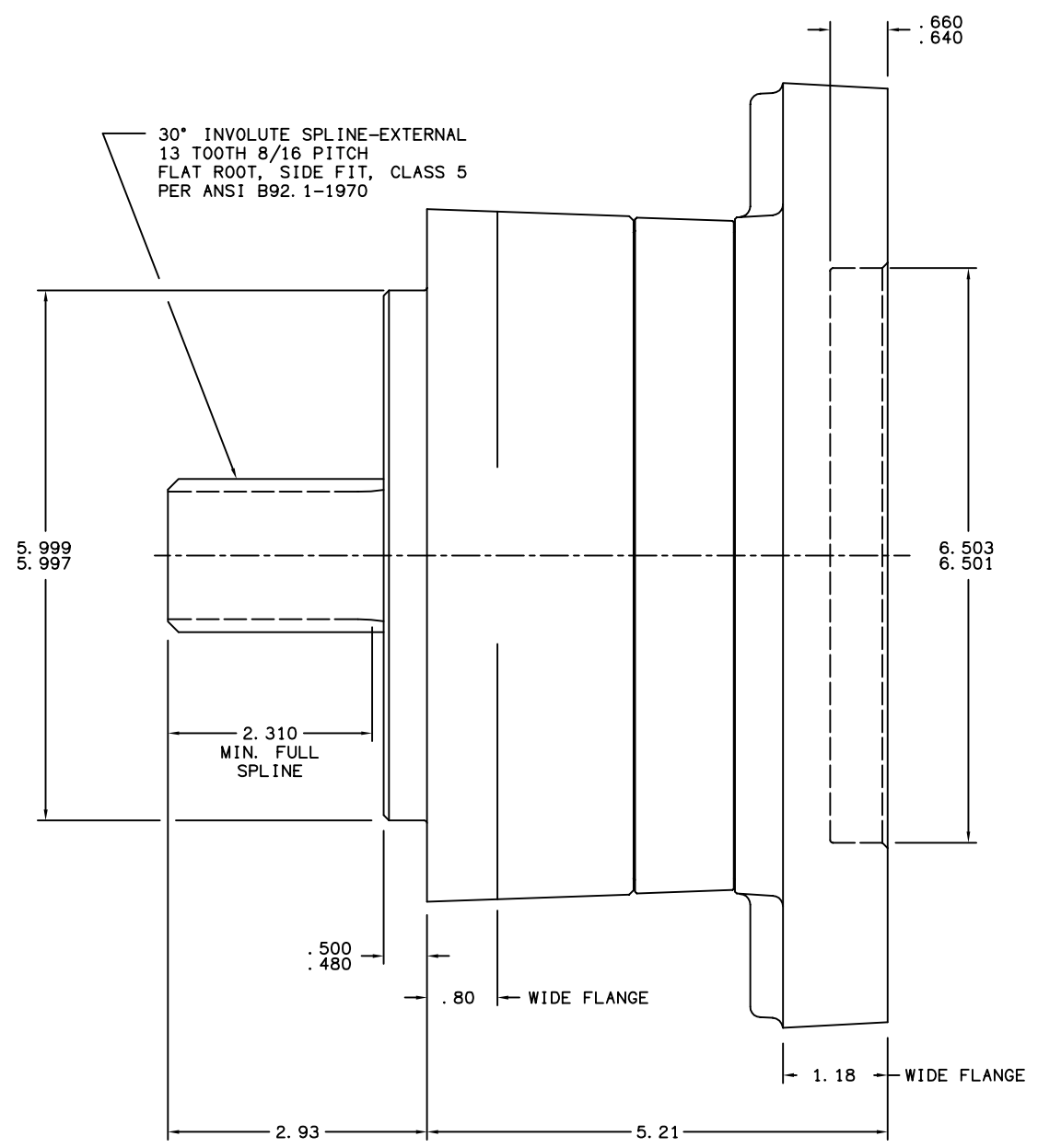

SECTION A-A

NOTES:

- 1) O-RING REPAIR KIT P/N 12-501-249
- 2) BEARING REPAIR KIT P/N 12-501-250
- 3) SPRING REPAIR KIT P/N 12-501-251
- 4) LINING REPAIR KIT P/N 12-501-306

SPECIFICATIONS:

**TYPE:** DRY MULTIPLE DISC BRAKE, SPRING APPLY, HYDRAULIC RELEASE

**TORQUE RATING:** 8,000 LB-IN STATIC (BREAKAWAY) AT 0 PSI BACK PRESSURE

**RELEASE PRESSURE:** 130 PSI INITIAL, 170 PSI FULL

**MAXIMUM OPERATING PRESSURE:** 3,000 PSI

**MAXIMUM SPEED:** 3,900 RPM

**APPROXIMATE WEIGHT:** 60 LBS.

FOR USE WITH MINERAL BASE HYDRAULIC OIL ONLY

<b>mico</b> North Mankato, Minnesota U.S.A.		
SCALE 1:1	PART NUMBER 13-552-044	REV. E
X NO.	CUSTOMER COPY	
DRAWN RAMOS		
REVISED		
DATE 4/14/99	CHECKED	APPROVED ENG.