

REV.	NPR OR ECO NO.	DATE
E	ECO S-1731	01/20/04

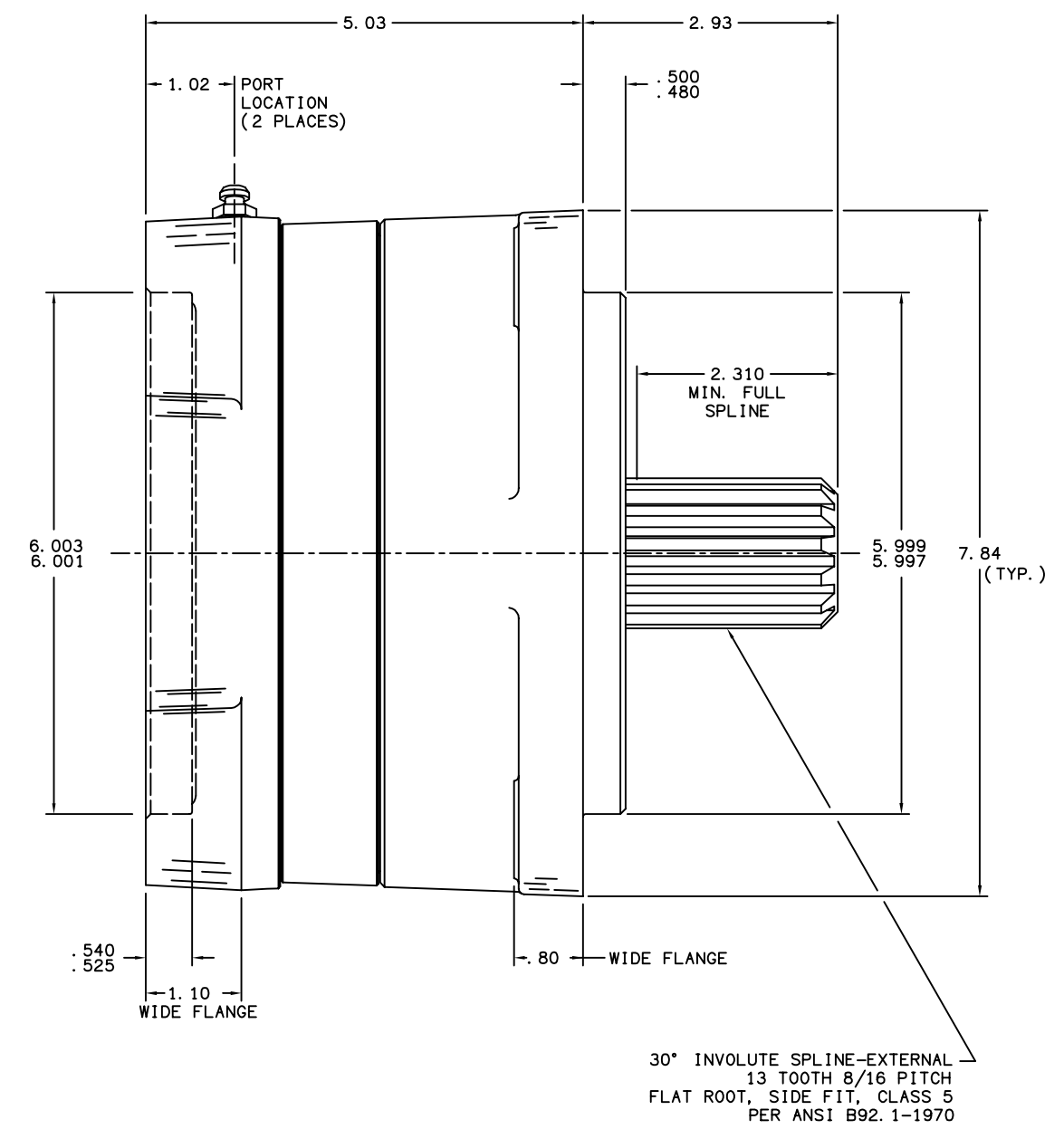
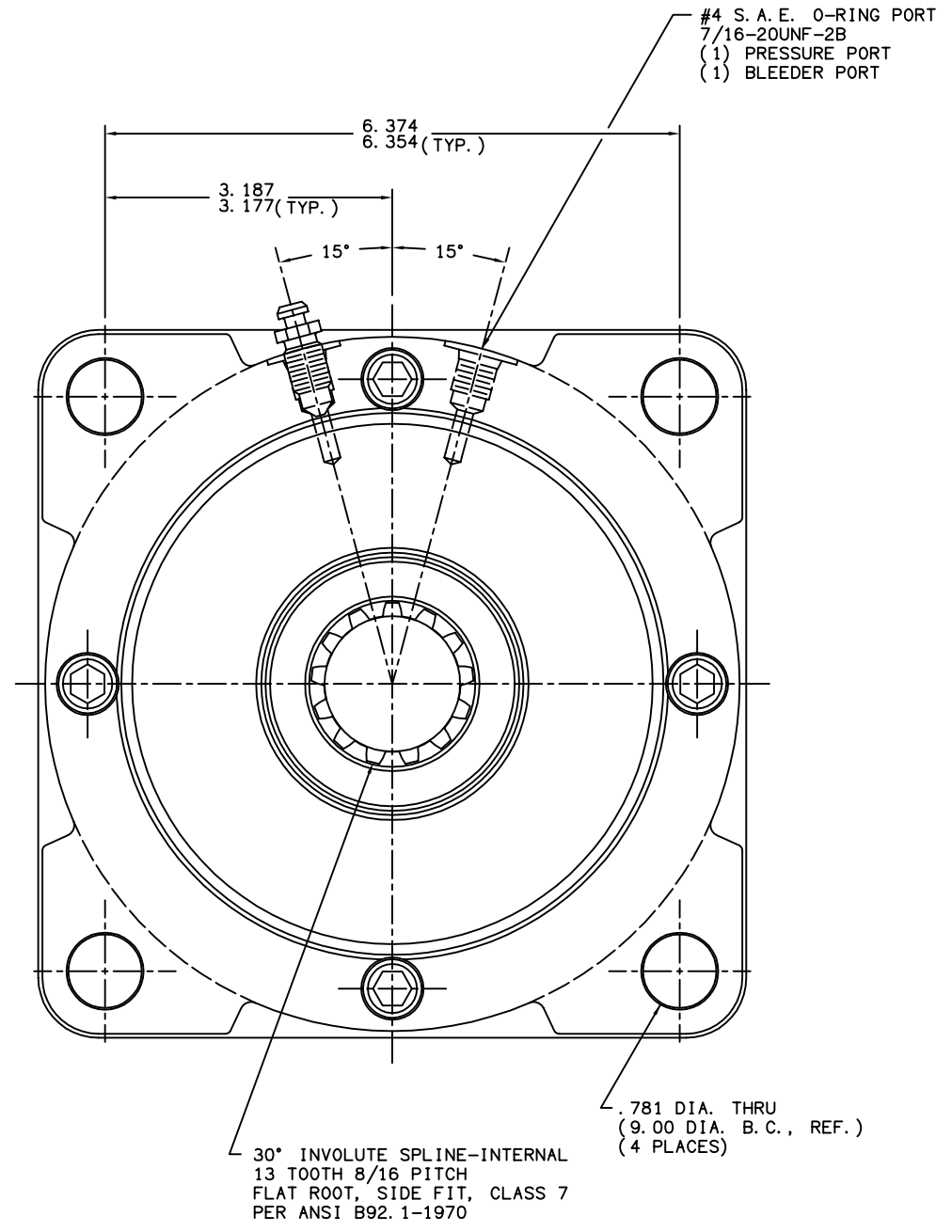

NOTES:

- 1) O-RING REPAIR KIT P/N 12-501-249
- 2) BEARING REPAIR KIT P/N 12-501-250
- 3) SPRING REPAIR KIT P/N 12-501-251
- 4) LINING REPAIR KIT P/N 12-501-306

SPECIFICATIONS:

TYPE: DRY MULTIPLE DISC BRAKE, SPRING APPLY, HYDRAULIC RELEASE

TORQUE RATING: 10,000 LB-IN STATIC (BREAKAWAY) AT 0 PSI BACK PRESSURE

RELEASE PRESSURE: 150 PSI INITIAL, 200 PSI FULL

MAXIMUM OPERATING PRESSURE: 3,000 PSI

MAXIMUM SPEED: 3,900 RPM

LINING MATERIAL: SINTERED BRONZE

APPROXIMATE WEIGHT: 52 LBS.
FOR USE WITH MINERAL BASE HYDRAULIC OIL ONLY.

MICO, INC. CLAIMS PROPRIETARY RIGHTS TO THE MATERIAL DISCLOSED IN THIS DOCUMENT. THIS DOCUMENT IS PROVIDED IN CONFIDENCE AND MAY NOT BE REPRODUCED OR DISCLOSED WITHOUT WRITTEN PERMISSION FROM MICO, INC. COPYRIGHT MICO, INC. ALL RIGHTS RESERVED.

mico		
North Mankato, Minnesota U.S.A.		
SCALE 1:2	PART NUMBER	REV.
X NO.	13-552-040	E
DRAWN G. J.	CUSTOMER COPY	
REVISED	DATE	CHECKED
	06/28/01	APPROVED ENG.KMM 06/28/01