

REV.	NPR OR ECO NO.	DATE
D	ECO S-1731	01/15/04

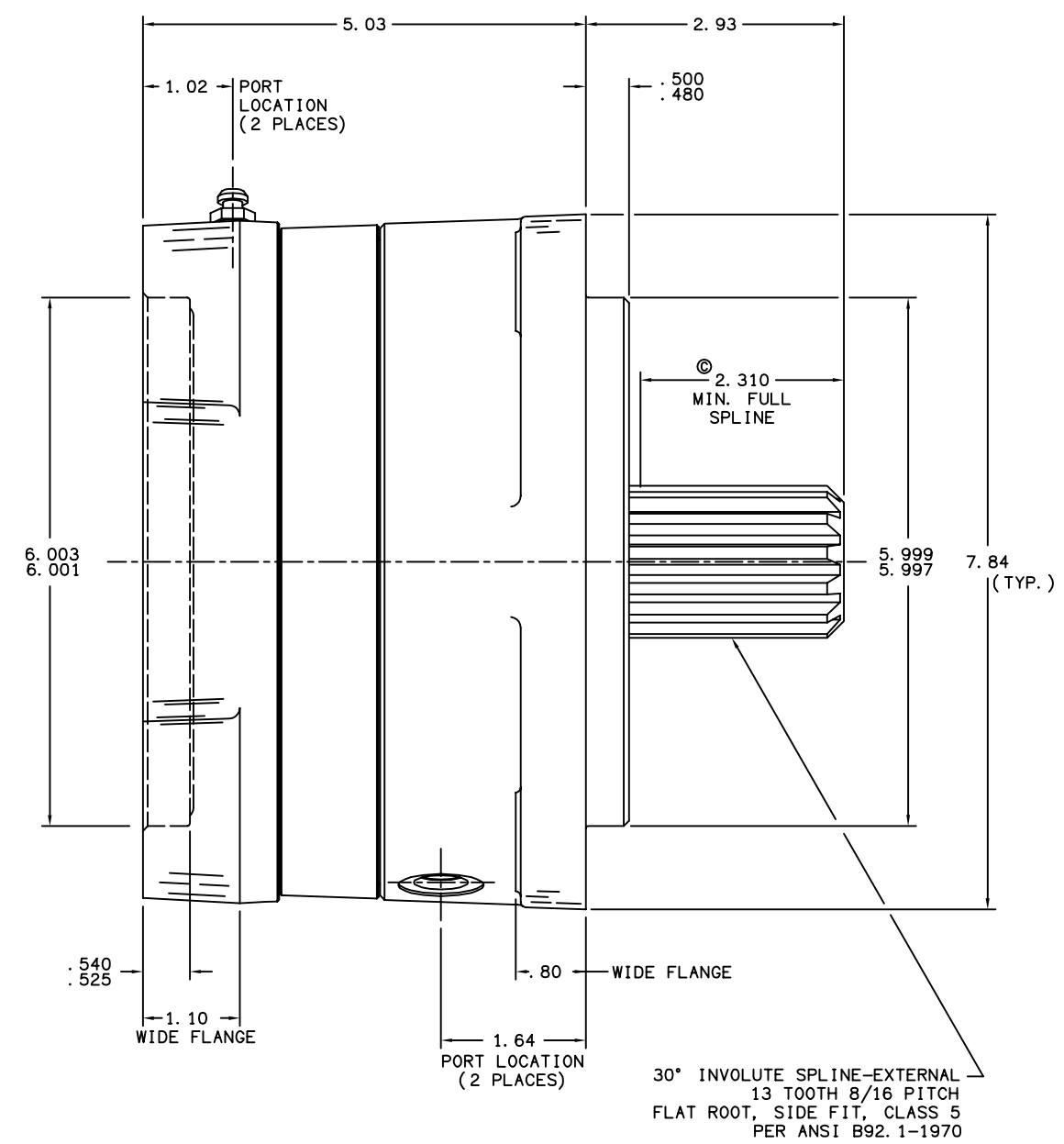
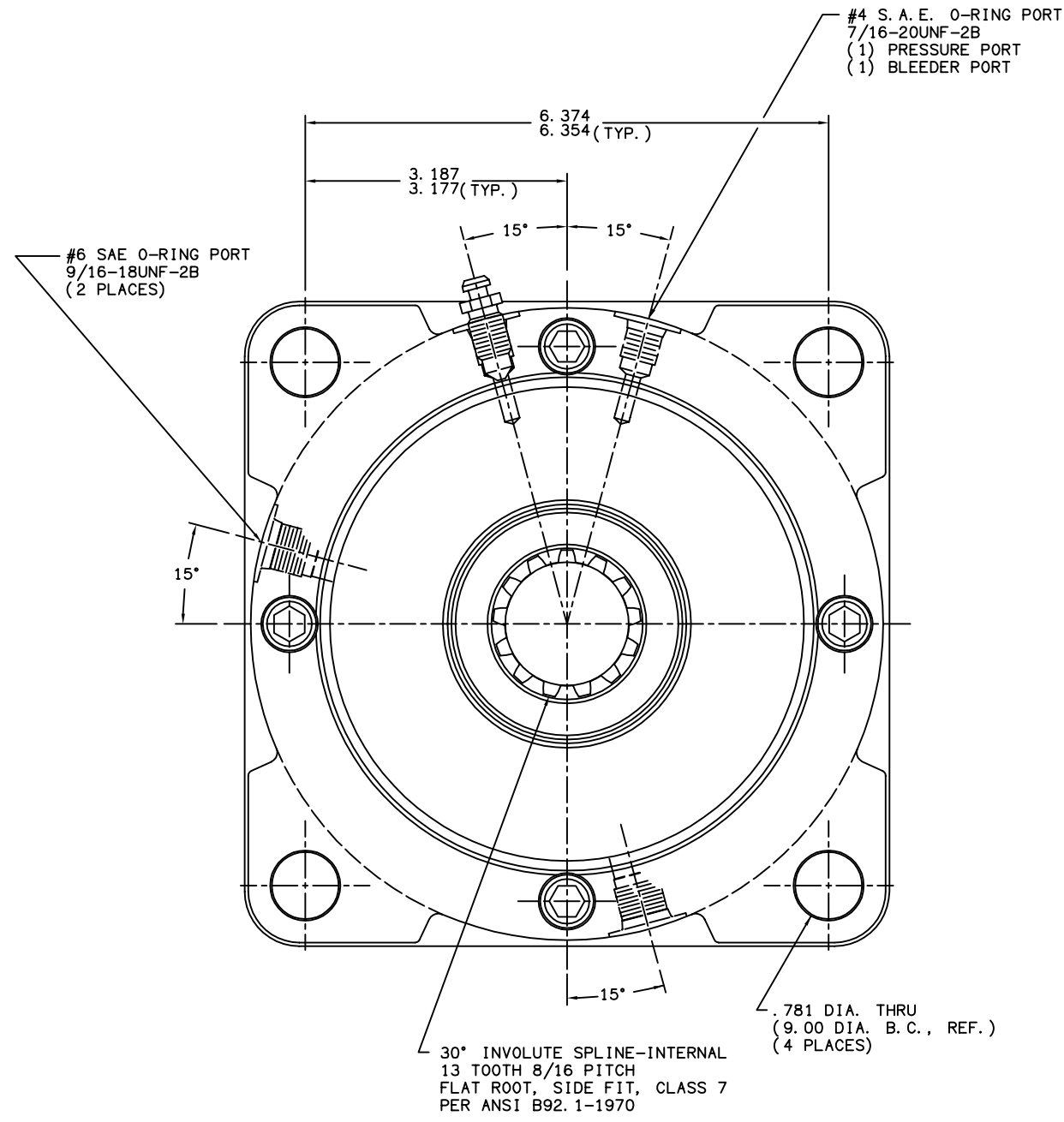

NOTES:

- 1) O-RING REPAIR KIT P/N 12-501-292
- 2) BEARING REPAIR KIT P/N 12-501-250
- 3) SPRING REPAIR KIT P/N 12-501-251
- 4) LINING REPAIR KIT P/N 12-501-306

SPECIFICATIONS:

TYPE:	WET MULTIPLE DISC BRAKE, SPRING APPLY, HYDRAULIC RELEASE
TORQUE RATING:	WET 16,000 LB-IN STATIC (BREAKAWAY) AT 0 PSI BACK PRESSURE DRY 24,000 LB-IN DRY TORQUE FOR BRAKE RATING AND SPECIFICATIONS ONLY
RELEASE PRESSURE:	330 PSI INITIAL, 470 PSI FULL
MAXIMUM OPERATING PRESSURE:	3,000 PSI
MAXIMUM SPEED:	3,900 RPM
LINING MATERIAL:	SINTERED BRONZE
APPROXIMATE WEIGHT:	52 LBS. FOR USE WITH MINERAL BASE HYDRAULIC OIL ONLY.

COOLING OIL RECOMMENDATIONS:

OIL TYPE: MINERAL BASE HYDRAULIC OIL SUCH AS MOBIL DTE 24, CITGO A/W 32 OR EQUIVALENT

FLOW THRU CAPACITY: 1.0 - 7.0 GPM

MAXIMUM CASE PRESSURE: 15 PSI

SUMP OIL VOLUME:
HORIZONTAL: 5 FL. OZ.
VERTICAL: CONTACT FACTORY

MICO North Mankato, Minnesota U.S.A.		
SCALE 1:2	PART NUMBER 13-552-022	REV. D
X NO.	CUSTOMER COPY	
DRAWN G. J.		
REVISION		
DATE 05/11/01	CHECKED	APPROVED ENG.

MICO, INC. CLAIMS PROPRIETARY RIGHTS TO THE MATERIAL DISCLOSED IN THIS DOCUMENT. THIS DOCUMENT IS PROVIDED IN CONFIDENCE AND MAY NOT BE REPRODUCED OR DISCLOSED WITHOUT WRITTEN PERMISSION FROM MICO, INC. COPYRIGHT MICO, INC. ALL RIGHTS RESERVED.