

| | | |
|---|----------------|---------------------------|
| TITLE MULTIPLE DISC BRAKE 3R-10317-D | | PART NUMBER 13-552-020 |
| REV. | NPR OR ECO NO. | DATE |
| C | ECO S-1731 | 01/16/03 |

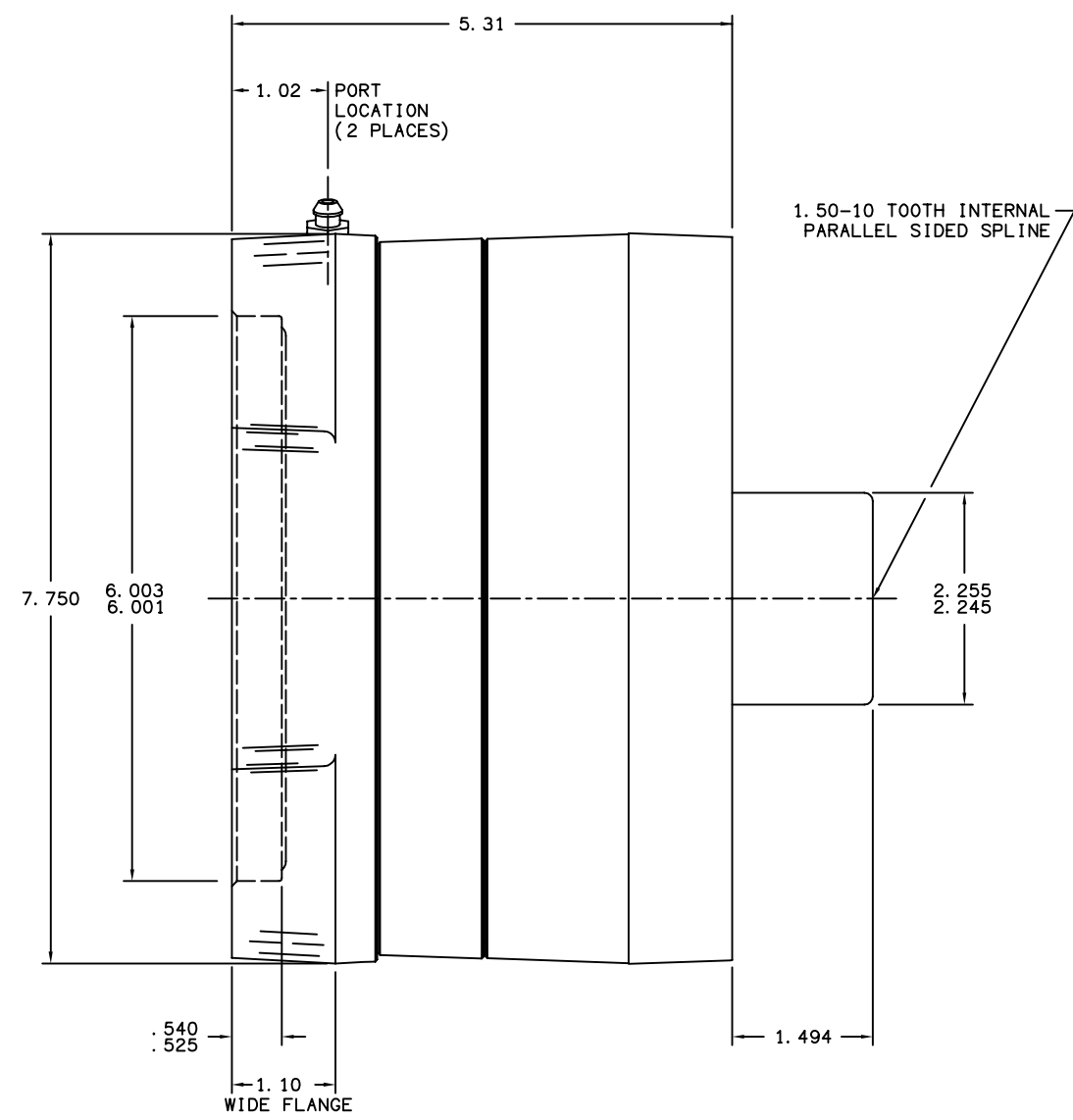
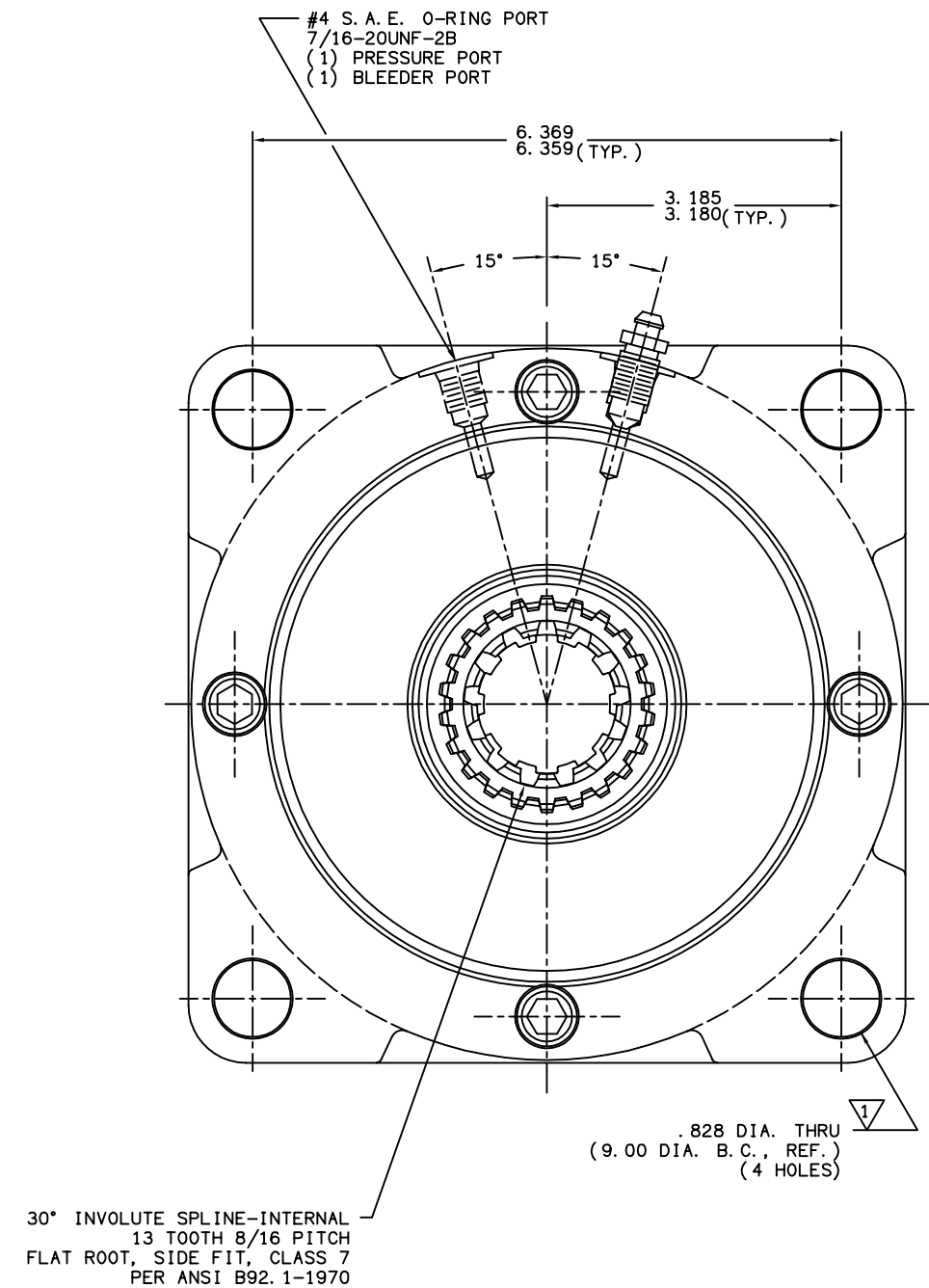

NOTES:

- 1) O-RING REPAIR KIT P/N 12-501-337
- 2) SPRING REPAIR KIT P/N 12-501-336
- 3) LINING REPAIR KIT P/N 12-501-338

SPECIFICATIONS:

| | |
|--|---|
| TYPE: | DRY MULTIPLE DISC BRAKE, SPRING APPLY, HYDRAULIC RELEASE |
| TORQUE RATING: | 17,500 IN. LBS. STATIC (BREAKAWAY) AT 0 PSI BACK PRESSURE |
| RELEASE PRESSURE: | 230 PSI INITIAL, 320 PSI FULL |
| MAXIMUM OPERATING PRESSURE: | 3,000 PSI |
| MAXIMUM SPEED: | 3,900 RPM |
| LINING MATERIAL: | SINTERED BRONZE |
| APPROXIMATE WEIGHT: | 52 LBS. |
| FOR USE WITH MINERAL BASE HYDRAULIC OIL ONLY | |

MICO, INC. CLAIMS PROPRIETARY RIGHTS TO THE MATERIAL DISCLOSED IN THIS DOCUMENT. THIS DOCUMENT IS PROVIDED IN CONFIDENCE AND MAY NOT BE REPRODUCED OR DISCLOSED WITHOUT WRITTEN PERMISSION FROM MICO, INC. COPYRIGHT MICO, INC. ALL RIGHTS RESERVED.

| | | |
|--|------------------------|---------------|
| mico North Mankato, Minnesota U.S.A. | | |
| SCALE 1:2 | PART NUMBER 13-552-020 | REV. C |
| X NO. | CUSTOMER COPY | |
| DRAWN G.J. | | |
| REVISED LH | | |
| DATE 11/08/01 | CHECKED | APPROVED ENG. |