

DRAWING NUMBER
13-547-362
NPI OR ECN NO
ECN000177

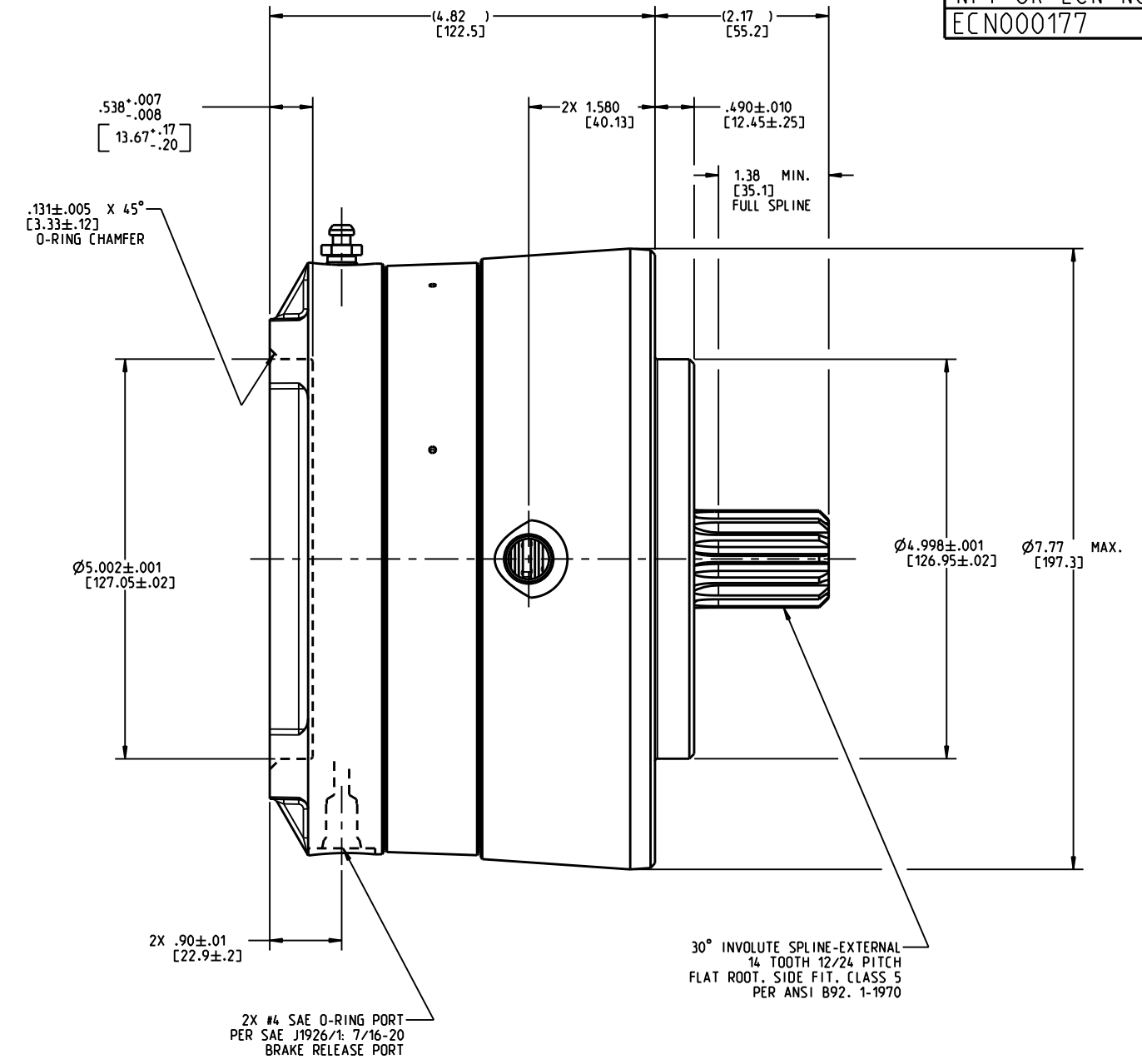
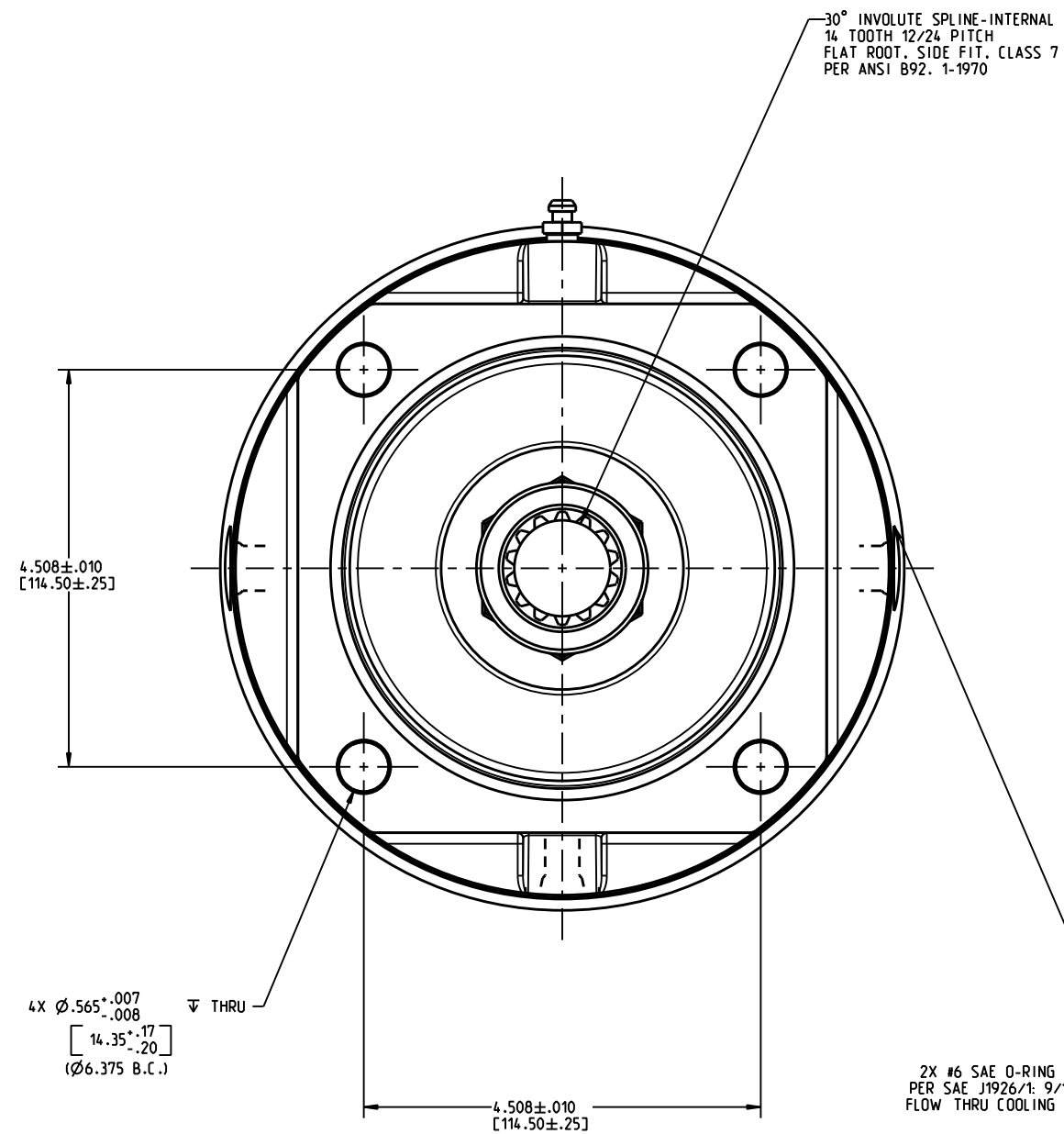

NOTES:

1. LINING REPAIR KIT P/N 12-501-004
2. BEARING REPAIR KIT P/N 12-501-006
3. O-RING REPAIR KIT P/N 12-501-002
4. SPRING REPAIR KIT P/N 12-501-008

SPECIFICATIONS:

TYPE: WET MULTIPLE DISC BRAKE, SPRING APPLY, HYDRAULIC RELEASE
 TORQUE RATING: WET 3000 LBIN STATIC (BREAKAWAY) AT 0 PSI BACK PRESSURE
 DRY 4500 LBIN DRY TORQUE FOR BRAKE RATING AND SPECIFICATIONS ONLY.
 TORQUE RATING MAY VARY UP TO ±10% DUE TO MANUFACTURING TOLERANCES.
 RELEASE PRESSURE: 110 PSI INITIAL, 150 PSI FULL
 MAXIMUM OPERATING PRESSURE: 3000 PSI
 MAXIMUM SPEED: 3900 RPM
 LINING MATERIAL: SINTERED BRONZE
 APPROXIMATE WEIGHT: 40 LBS

FOR USE WITH MINERAL BASE HYDRAULIC OIL ONLY

COOLING OIL RECOMMENDATIONS:

OIL TYPE: MINERAL BASE HYDRAULIC OIL SUCH AS MOBILE DTE 24, CITGO A/W 32 OR EQUIVLENT
FLOW THRU CAPACITY: 1.0 - 7.0 GPM
MAXIMUM CASE PRESSURE: 15 PSI
SUMP OIL VOLUME: HORIZONTAL: 4 FL. OZ. VERTICAL: CONTACT FACTORY

INCH
[MILLIMETER]



COMPONENT AND SYSTEM RECOMMENDATIONS MADE BY MICO, INC ARE BASED ON INFORMATION SUPPLIED BY POTENTIAL USER AND/OR SYSTEM DESIGNER. THE POTENTIAL USER AND/OR DESIGNER MUST MAKE FINAL ACCEPTANCE AND APPROVAL OF COMPONENTS AND SYSTEM AFTER TESTING PERFORMANCE ON AN ACTUAL APPLICATION FOR WHICH SYSTEM WAS DESIGNED.		MICO, INC CLAIMS PROPRIETARY RIGHTS TO THE MATERIAL DISCLOSED IN THIS DOCUMENT. THIS DOCUMENT IS PROVIDED IN CONFIDENCE AND MAY NOT BE REPRODUCED OR DISCLOSED WITHOUT WRITTEN PERMISSION FROM MICO, INC. COPYRIGHT MICO, INC. ALL RIGHTS RESERVED.	
SCALE 0.500	TITLE 3C-141445-CZ MULTIPLE DISC BRAKE	SIZE B	DRAWING NUMBER 13-547-362
DWN MAP 2008-12-10	APVD PROD ENGRG PJS 2009-01-26	REV F	CUSTOMER COPY
X NO .	APVD ENGRG BLF 2008-12-11		