

TITLE C-MOUNT GEARBOX BRAKE		PART NUMBER 13-538-380
REV.	NPR OR ECO NO.	DATE
C	ECO S-1729	05/27/03

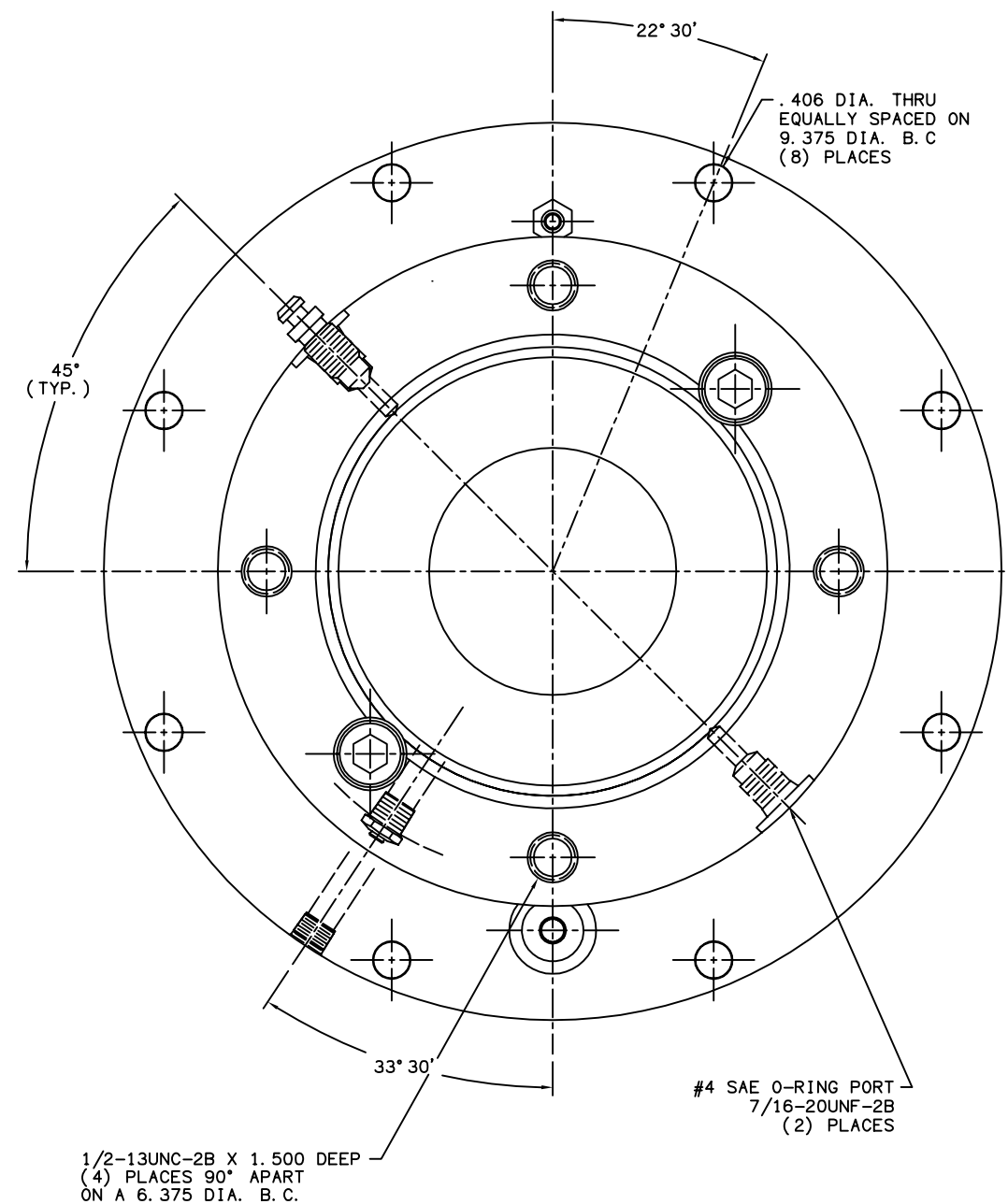
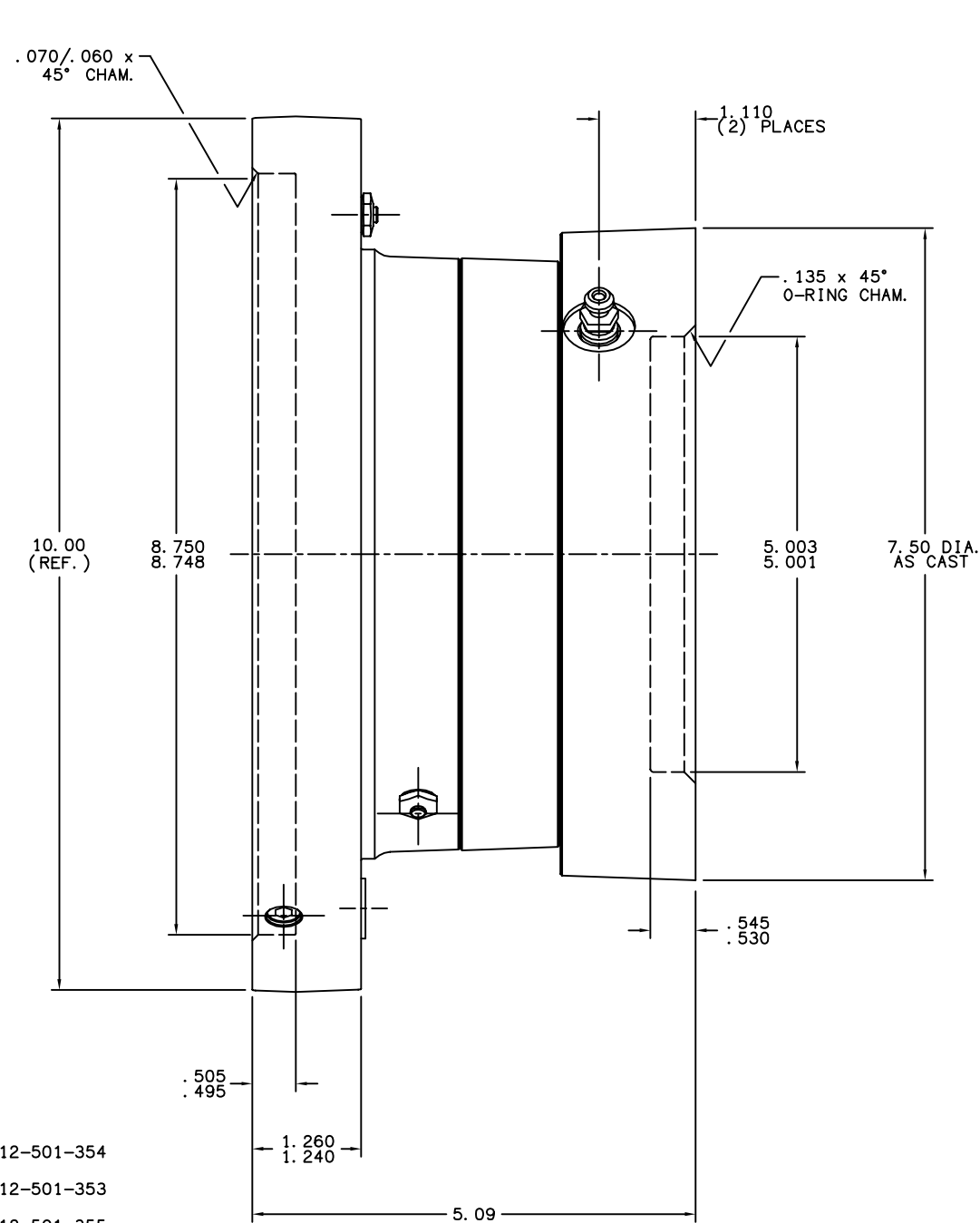

**NOTES:**

- 1) LINING REPAIR KIT P/N 12-501-354
- 2) O-RING REPAIR KIT P/N 12-501-353
- 3) SPRING REPAIR KIT P/N 12-501-355

**SPECIFICATIONS:**

**TYPE:** DRY MULTIPLE DISC BRAKE, SPRING APPLY, HYDRAULIC RELEASE

**TORQUE RATING:** 4,800 LB-IN STATIC (BREAKAWAY) AT 0 PSI BACK PRESSURE

**RELEASE PRESSURE:** 170 PSI INITIAL, 200 PSI FULL

**MAXIMUM OPERATING PRESSURE:** 3,000 PSI

**MAXIMUM SPEED:** 3,900 RPM

**APPROXIMATE WEIGHT:** 37 LBS.

FOR USE WITH MINERAL BASE HYDRAULIC OIL ONLY

MICO, INC. CLAIMS PROPRIETARY RIGHTS TO THE MATERIAL DISCLOSED IN THIS DOCUMENT. THIS DOCUMENT IS PROVIDED IN CONFIDENCE AND MAY NOT BE REPRODUCED OR DISCLOSED WITHOUT WRITTEN PERMISSION FROM MICO, INC. COPYRIGHT MICO, INC. ALL RIGHTS RESERVED.

<b>mico</b> North Mankato, Minnesota U.S.A.		
SCALE 1:2	PART NUMBER	REV.
X NO. X6612	13-538-380	C
DRAWN G.J.	CUSTOMER COPY	
REVISED LH	CHECKED	APPROVED
DATE 11/24/98	ENG.	