

TITLE MULTIPLE DISC BRAKE		PART NUMBER 13-538-374	
REV.	NPR OR ECO NO.	DATE	
B	ECO S-1729	05/27/03	

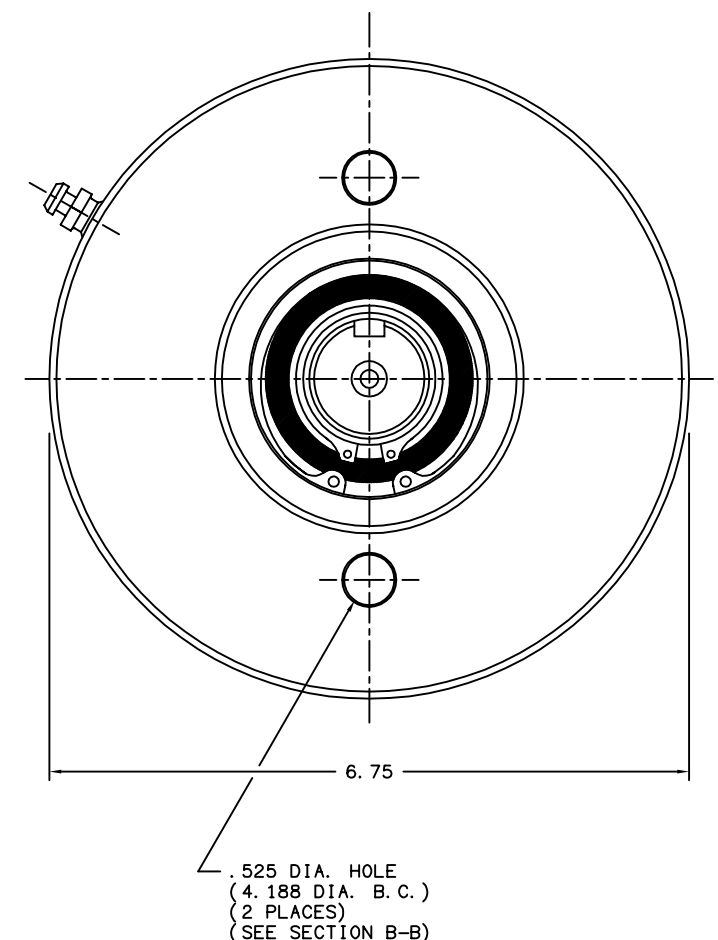
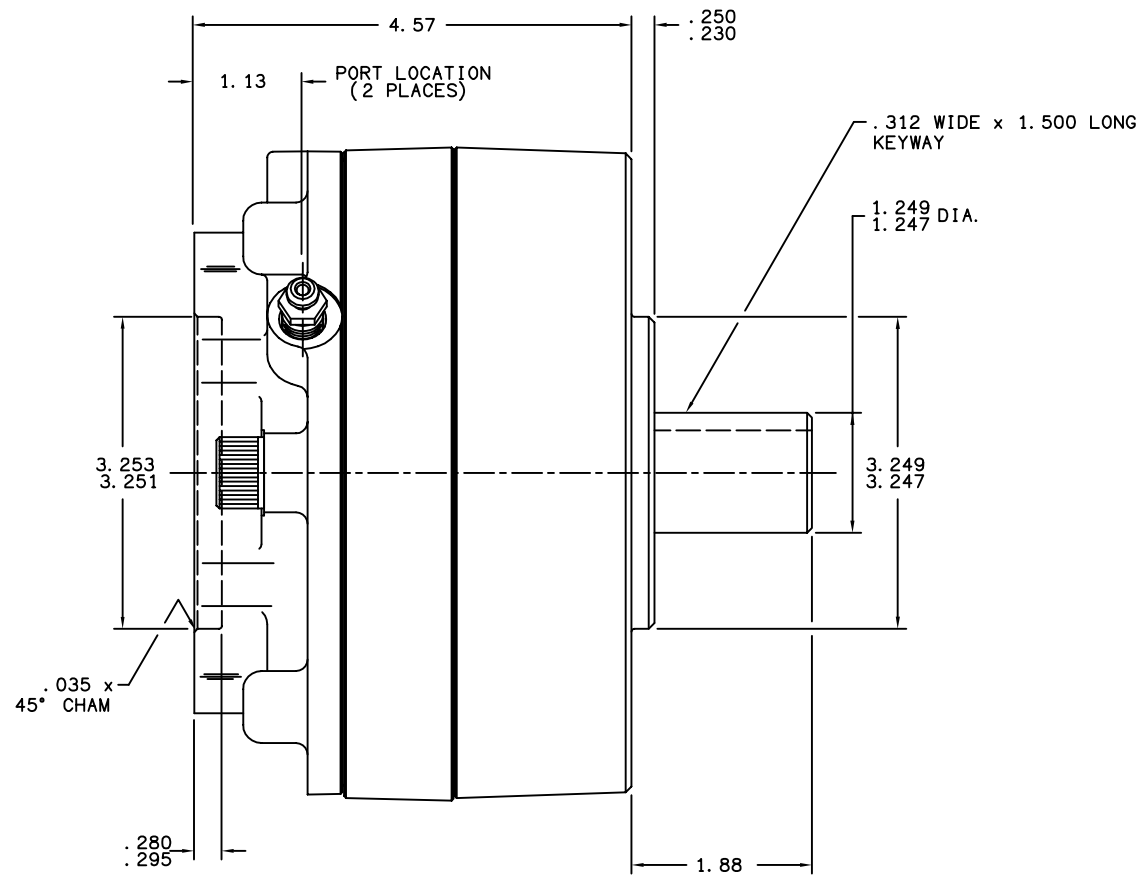
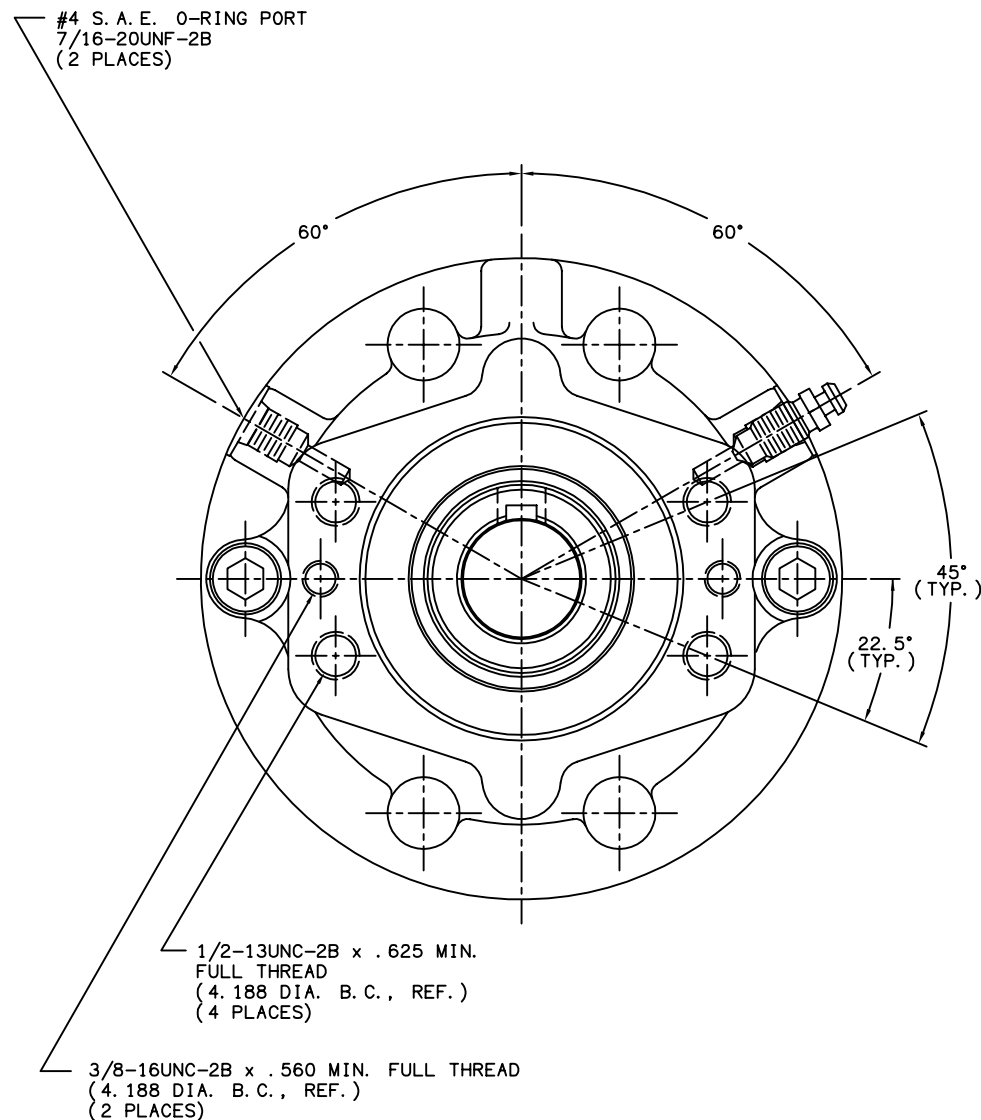

**NOTES:**

- 1) LINING REPAIR KIT P/N 12-501-243
- 2) BEARING REPAIR KIT P/N 12-501-241
- 3) O-RING REPAIR KIT P/N 12-501-246
- 4) SPRING REPAIR KIT P/N 12-501-244
- 5) REFER TO INSTALLATION SHEET #81-538-002 (SUPPLIED WITH BRAKE) FOR FURTHER MOUNTING INSTRUCTIONS.

**SPECIFICATIONS:**

**TYPE:** DRY MULTIPLE DISC BRAKE, SPRING APPLY, HYDRAULIC RELEASE

**TORQUE RATING:** 2,400 LB-IN STATIC (BREAKAWAY) AT 0 PSI BACK PRESSURE

**RELEASE PRESSURE:** 100 PSI INITIAL, 120 PSI FULL

**MAXIMUM OPERATING PRESSURE:** 3,000 PSI

**MAXIMUM SPEED:** 3,900 RPM

**APPROXIMATE WEIGHT:** 27 LBS.

FOR USE WITH MINERAL BASE HYDRAULIC OIL ONLY

MICO, INC. CLAIMS PROPRIETARY RIGHTS TO THE MATERIAL DISCLOSED IN THIS DOCUMENT. THIS DOCUMENT IS PROVIDED IN CONFIDENCE AND MAY NOT BE REPRODUCED OR DISCLOSED WITHOUT WRITTEN PERMISSION FROM MICO, INC. COPYRIGHT MICO, INC. ALL RIGHTS RESERVED.

<b>mico</b> North Mankato, Minnesota U.S.A.		
SCALE 1:2	PART NUMBER 13-538-374	REV. B
X NO.	CUSTOMER COPY	
DRAWN G.J.		
REVISED LH		
DATE 9/24/98	CHECKED	APPROVED ENG.