

TITLE MULTIPLE DISC BRAKE 3A-141490-MDT		PART NUMBER 13-538-364
REV.	NPR OR ECO NO.	DATE
F	ECO S-1729	05/27/03

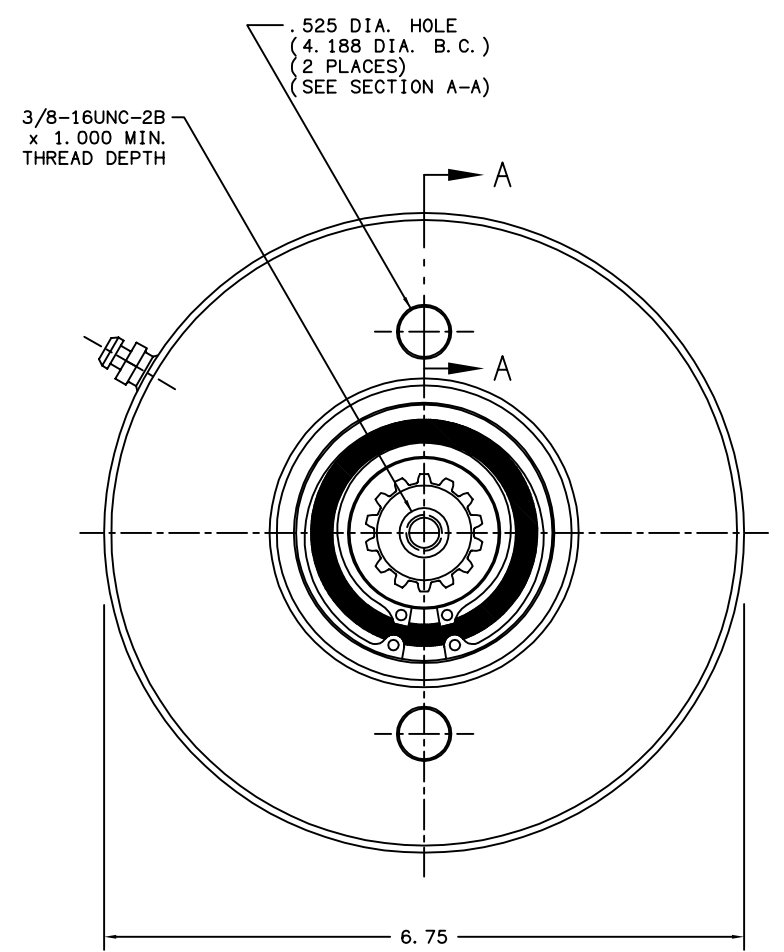
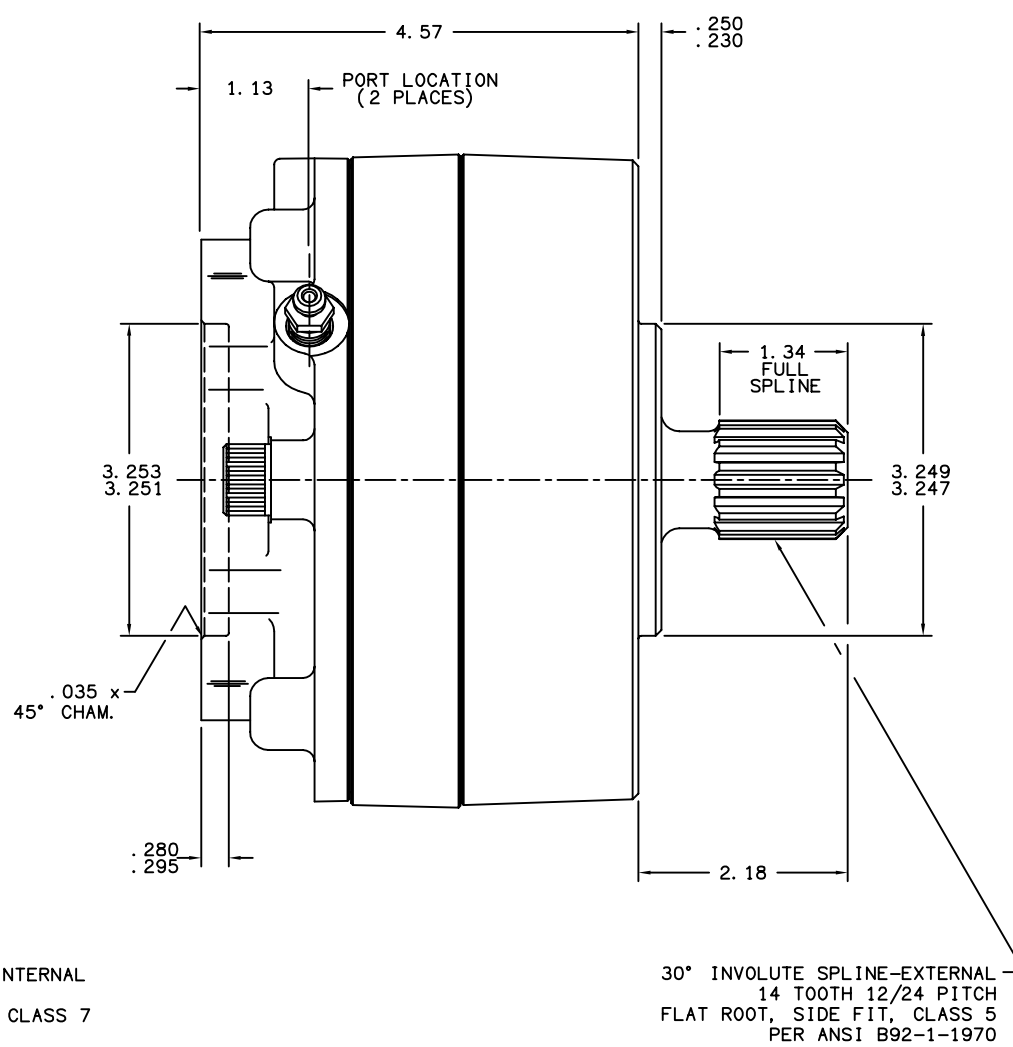
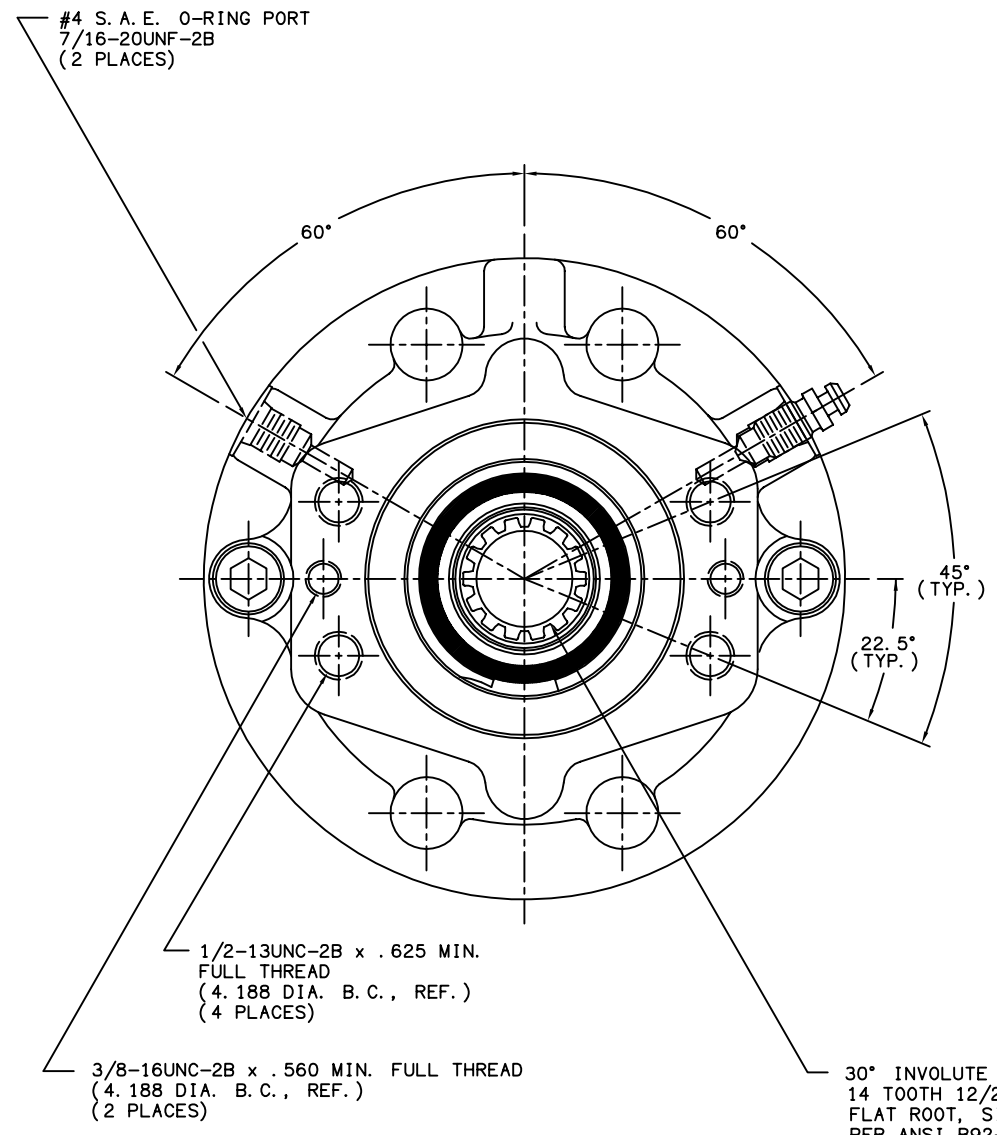

**NOTES:**

- 1) LINING REPAIR KIT P/N 12-501-243
- 2) BEARING REPAIR KIT P/N 12-501-253
- 3) O-RING REPAIR KIT P/N 12-501-246
- 4) SPRING REPAIR KIT P/N 12-501-244
- 5) REFER TO INSTALLATION SHEET #81-538-002 (SUPPLIED WITH BRAKE) FOR FURTHER MOUNTING INSTRUCTIONS.

**SPECIFICATIONS:**

<b>TYPE:</b>	DRY MULTIPLE DISC BRAKE, SPRING APPLY, HYDRAULIC RELEASE
<b>TORQUE RATING:</b>	9,000 LB-IN STATIC (BREAKAWAY) AT 0 PSI BACK PRESSURE
<b>RELEASE PRESSURE:</b>	330 PSI INITIAL, 390 PSI FULL
<b>MAXIMUM OPERATING PRESSURE:</b>	3,000 PSI
<b>MAXIMUM SPEED:</b>	3,900 RPM
<b>APPROXIMATE WEIGHT:</b>	27 LBS.
FOR USE WITH MINERAL BASE HYDRAULIC OIL ONLY	

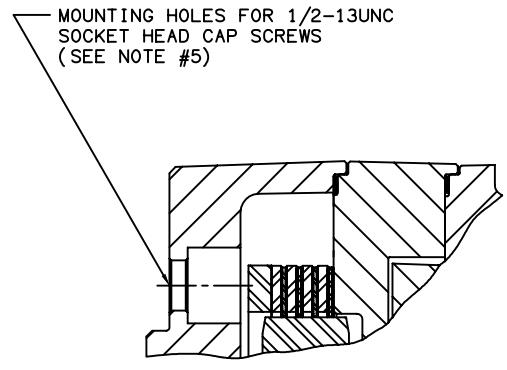

SECTION A-A

MICO, INC. CLAIMS PROPRIETARY RIGHTS TO THE MATERIAL DISCLOSED IN THIS DOCUMENT. THIS DOCUMENT IS PROVIDED IN CONFIDENCE AND MAY NOT BE REPRODUCED OR DISCLOSED WITHOUT WRITTEN PERMISSION FROM MICO, INC. COPYRIGHT MICO, INC. ALL RIGHTS RESERVED.

<b>mico</b> North Mankato, Minnesota U.S.A.		REV.
SCALE 1:2	PART NUMBER 13-538-364	F
X NO.	CUSTOMER COPY	
DRAWN G.J.	REVISIONS LH	
DATE 12/03/98	CHECKED	APPROVED ENG.