

TITLE MULTIPLE DISC BRAKE 3A-141490-M		PART NUMBER 13-538-320
REV.	NPR OR ECO NO.	DATE
E	ECO S-1729	05/27/03

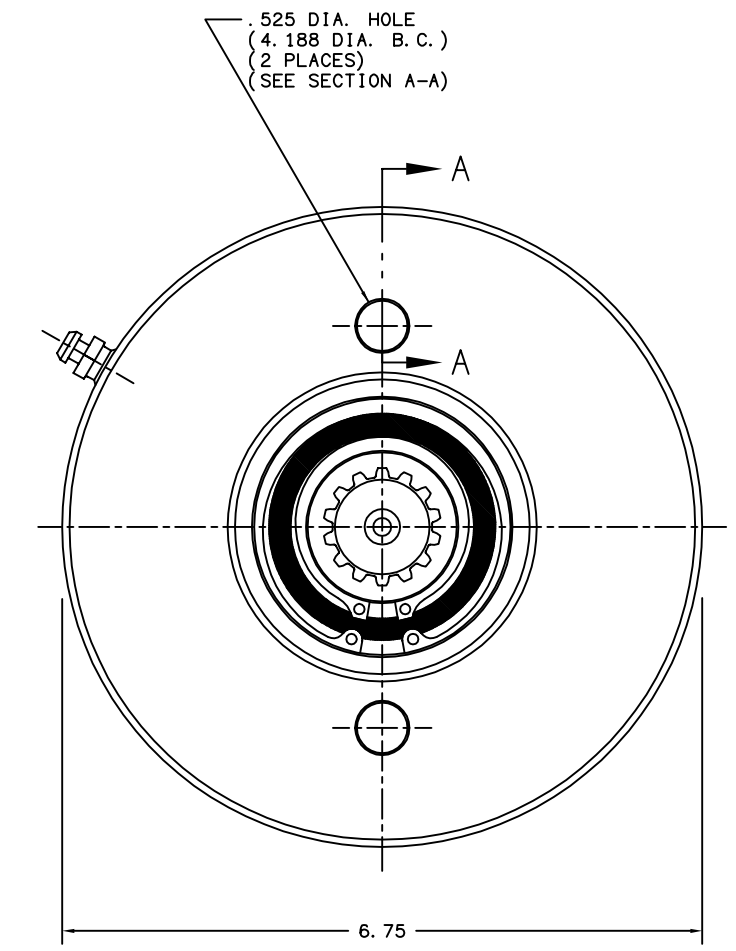
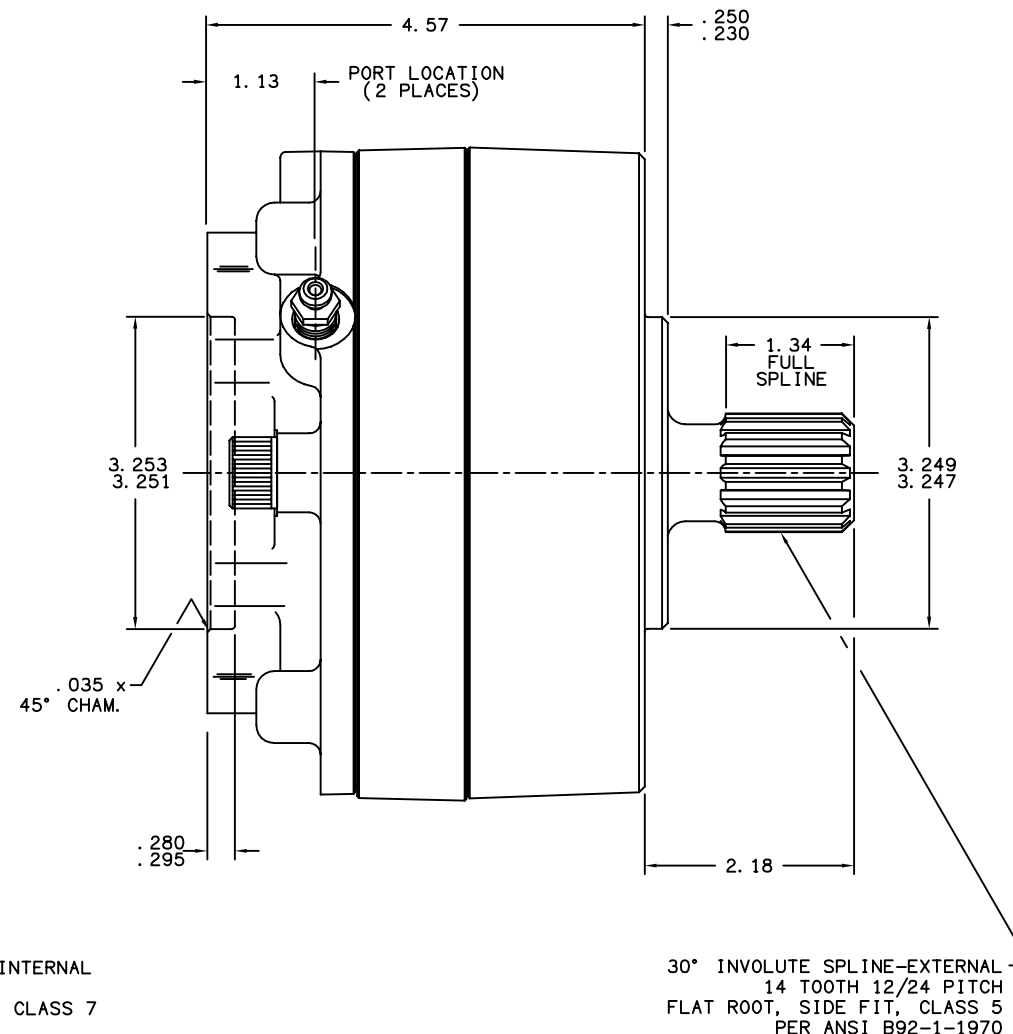
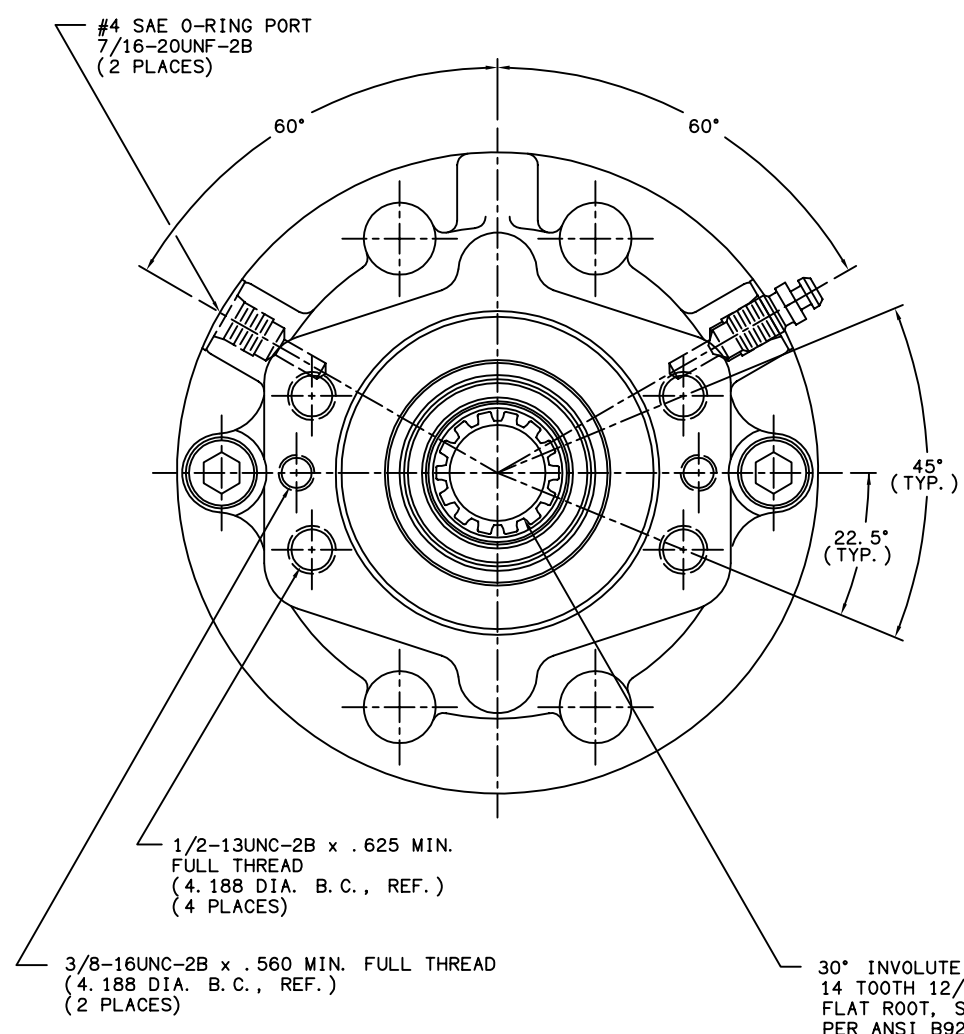

NOTES:

- 1) LINING REPAIR KIT P/N 12-501-243
- 2) BEARING REPAIR KIT P/N 12-501-242
- 3) O-RING REPAIR KIT P/N 12-501-246
- 4) SPRING REPAIR KIT P/N 12-501-244
- 5) REFER TO INSTALLATION SHEET #81-538-002 (SUPPLIED WITH BRAKE) FOR FURTHER MOUNTING INSTRUCTIONS.

SPECIFICATIONS:

TYPE:	DRY MULTIPLE DISC BRAKE, SPRING APPLY, HYDRAULIC RELEASE
TORQUE RATING:	9,000 LB-IN STATIC (BREAKAWAY) AT 0 PSI BACK PRESSURE
RELEASE PRESSURE:	330 PSI INITIAL, 390 PSI FULL
MAXIMUM OPERATING PRESSURE:	3,000 PSI
MAXIMUM SPEED:	3,900 RPM
APPROXIMATE WEIGHT:	27 LBS.
FOR USE WITH MINERAL BASE HYDRAULIC OIL ONLY	

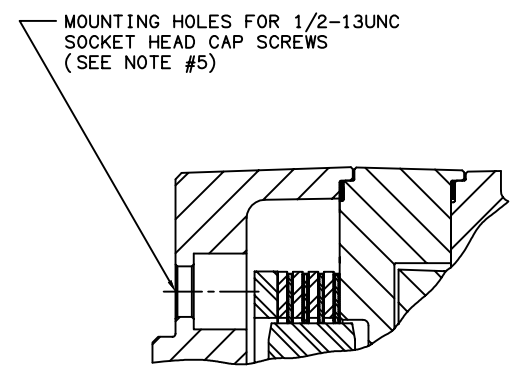

SECTION A-A

MICO, INC. CLAIMS PROPRIETARY RIGHTS TO THE MATERIAL DISCLOSED IN THIS DOCUMENT. THIS DOCUMENT IS PROVIDED IN CONFIDENCE AND MAY NOT BE REPRODUCED OR DISCLOSED WITHOUT WRITTEN PERMISSION FROM MICO, INC. COPYRIGHT MICO, INC. ALL RIGHTS RESERVED.

mico North Mankato, Minnesota U.S.A.		REV.
SCALE 1:2	PART NUMBER	E
X NO.	13-538-320	
DRAWN G.J.	CUSTOMER COPY	
REVISED LH		
DATE 12/03/98	CHECKED	APPROVED ENG.