

| | | |
|--|----------------|---------------------------|
| TITLE MULTIPLE DISC BRAKE 3A-100625-M | | PART NUMBER 13-538-294 |
| REV. | NPR OR ECO NO. | DATE |
| G | ECN000131 | 07/06/06 |

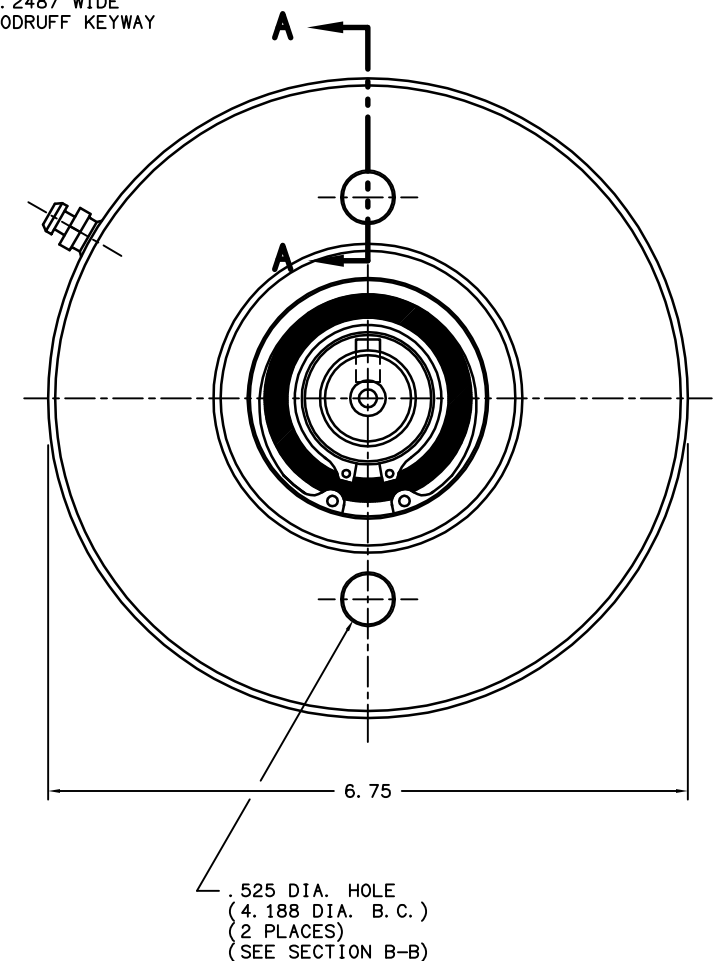
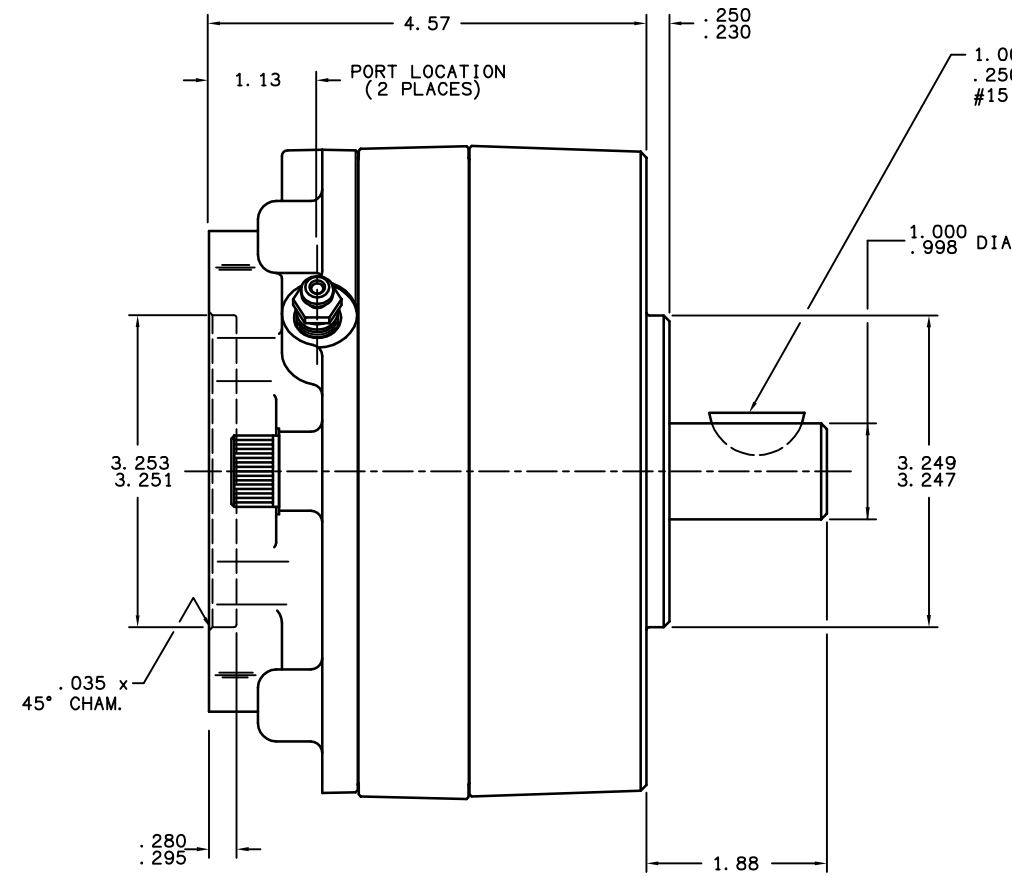
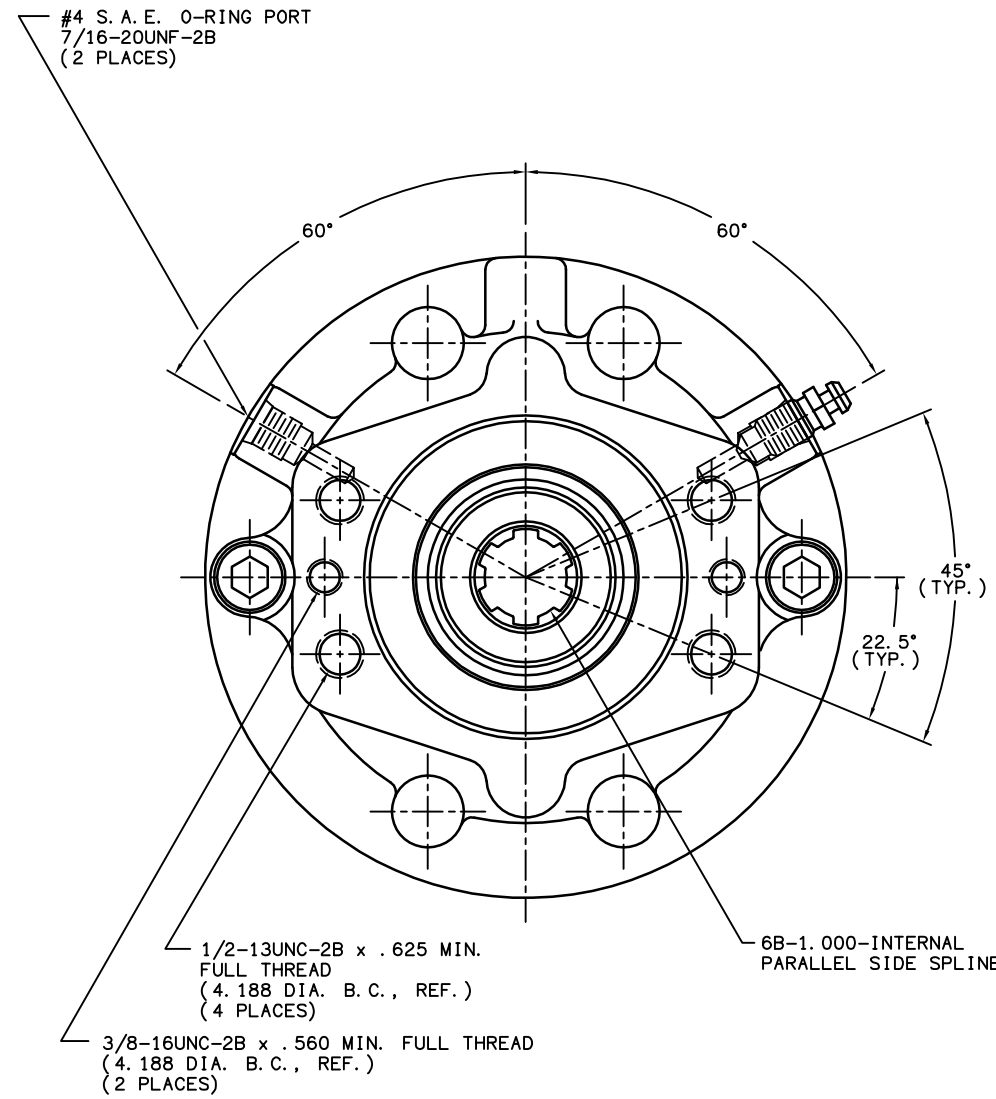

NOTES:

- 1) LINING REPAIR KIT P/N 12-501-245
- 2) BEARING REPAIR KIT P/N 12-501-241
- 3) O-RING REPAIR KIT P/N 12-501-246
- 4) SPRING REPAIR KIT P/N 12-501-244
- 5) REFER TO INSTALLATION SHEET #81-538-002 (SUPPLIED WITH BRAKE) FOR FURTHER MOUNTING INSTRUCTIONS.

SPECIFICATIONS:

| | |
|--|--|
| TYPE: | DRY MULTIPLE DISC BRAKE, SPRING APPLY, HYDRAULIC RELEASE |
| TORQUE RATING: | 2,500 LB-IN STATIC (BREAKAWAY) AT 0 PSI BACK PRESSURE |
| RELEASE PRESSURE: | 130 PSI INITIAL, 150 PSI FULL |
| MAXIMUM OPERATING PRESSURE: | 3,000 PSI |
| MAXIMUM SPEED: | 3,900 RPM |
| APPROXIMATE WEIGHT: | 27 LBS. |
| FOR USE WITH MINERAL BASE HYDRAULIC OIL ONLY | |

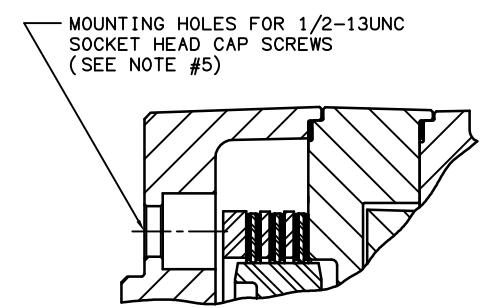

SECTION A-A

MICO, INC. CLAIMS PROPRIETARY RIGHTS TO THE MATERIAL DISCLOSED IN THIS DOCUMENT. THIS DOCUMENT IS PROVIDED IN CONFIDENCE AND MAY NOT BE REPRODUCED OR DISCLOSED WITHOUT WRITTEN PERMISSION FROM MICO, INC. COPYRIGHT MICO, INC. ALL RIGHTS RESERVED.

| | | | |
|--------------|------------------------|---------------------------------|--|
| mico | | North Mankato, Minnesota U.S.A. | |
| SCALE 1:2 | PART NUMBER 13-538-294 | REV. G | |
| X NO. | CUSTOMER COPY | | |
| DRAWN G.J. | | | |
| REVISED AO | | | |
| DATE 07/2006 | CHECKED | APPROVED ENG. | |