

| | | |
|------------------------------------------|----------------|---------------------------|
| TITLE MULTIPLE DISC BRAKE 3M-141456-M | | PART NUMBER 13-538-234 |
| REV. | NPR OR ECO NO. | DATE |
| F | ECO S-1729 | 05/23/03 |

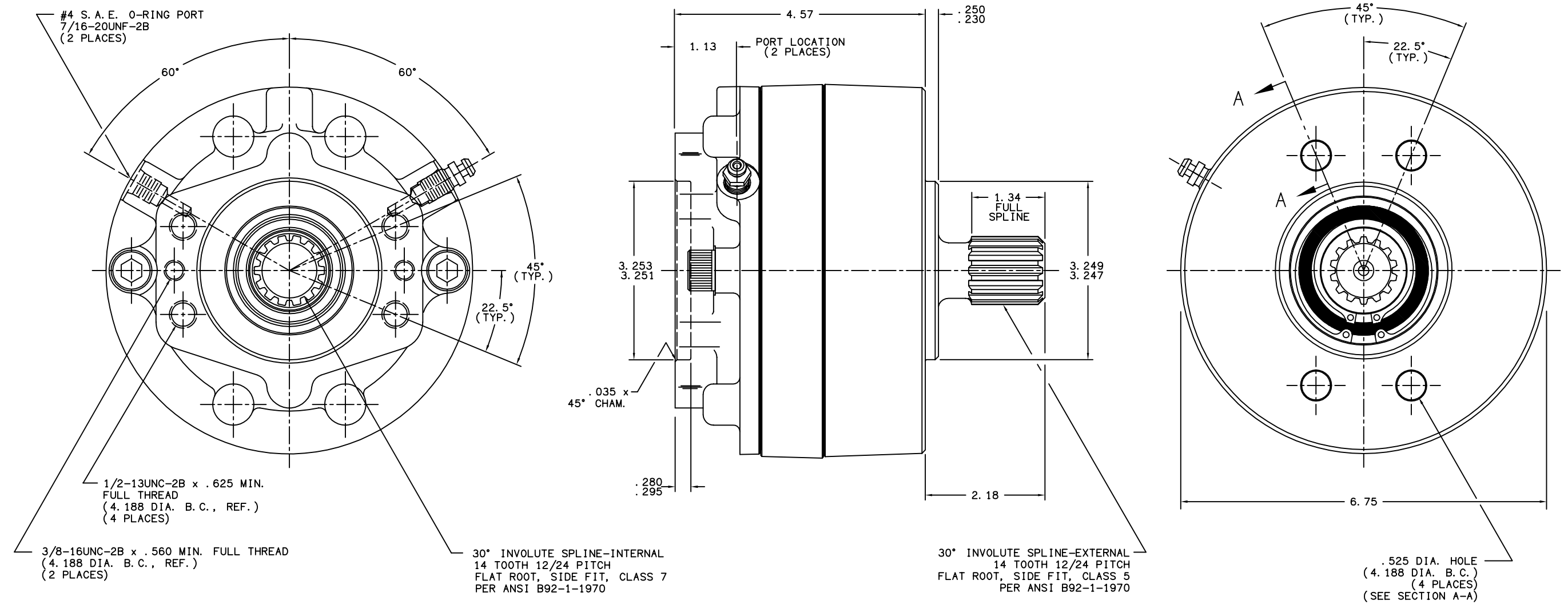

NOTES:

- 1) LINING REPAIR KIT P/N 12-501-243
- 2) REPAIR KIT P/N 12-501-242
- 3) O-RING REPAIR KIT P/N 12-501-246
- 4) SPRING REPAIR KIT P/N 12-501-244
- 5) REFER TO INSTALLATION SHEET #81-538-002 (SUPPLIED WITH BRAKE) FOR FURTHER MOUNTING INSTRUCTIONS.

SPECIFICATIONS:

| | |
|----------------------------------------------|----------------------------------------------------------|
| TYPE: | DRY MULTIPLE DISC BRAKE, SPRING APPLY, HYDRAULIC RELEASE |
| TORQUE RATING: | 5,600 LB-IN STATIC (BREAKAWAY) AT 0 PSI BACK PRESSURE |
| RELEASE PRESSURE: | 210 PSI INITIAL, 250 PSI FULL |
| MAXIMUM OPERATING PRESSURE: | 3,000 PSI |
| MAXIMUM SPEED: | 3,900 RPM |
| APPROXIMATE WEIGHT: | 27 LBS. |
| FOR USE WITH MINERAL BASE HYDRAULIC OIL ONLY | |

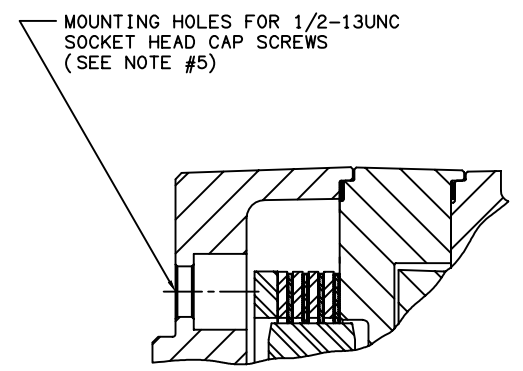

SECTION A-A

MICO, INC. CLAIMS PROPRIETARY RIGHTS TO THE MATERIAL DISCLOSED IN THIS DOCUMENT. THIS DOCUMENT IS PROVIDED IN CONFIDENCE AND MAY NOT BE REPRODUCED OR DISCLOSED WITHOUT WRITTEN PERMISSION FROM MICO, INC. COPYRIGHT MICO, INC. ALL RIGHTS RESERVED.

| | | |
|------------------------------------------------|------------------------|---------------|
| mico North Mankato, Minnesota U.S.A. | | REV. |
| SCALE 1:2 | PART NUMBER 13-538-234 | F |
| X NO. | CUSTOMER COPY | |
| DRAWN G.J. | CHECKED | APPROVED ENG. |
| REVISED LH | DATE 12/03/98 | |