

TITLE MULTIPLE DISC BRAKE 3M-060640-M		PART NUMBER 13-538-064
REV.	NPR OR ECO NO.	DATE
C	ECO S-1729	05/22/03

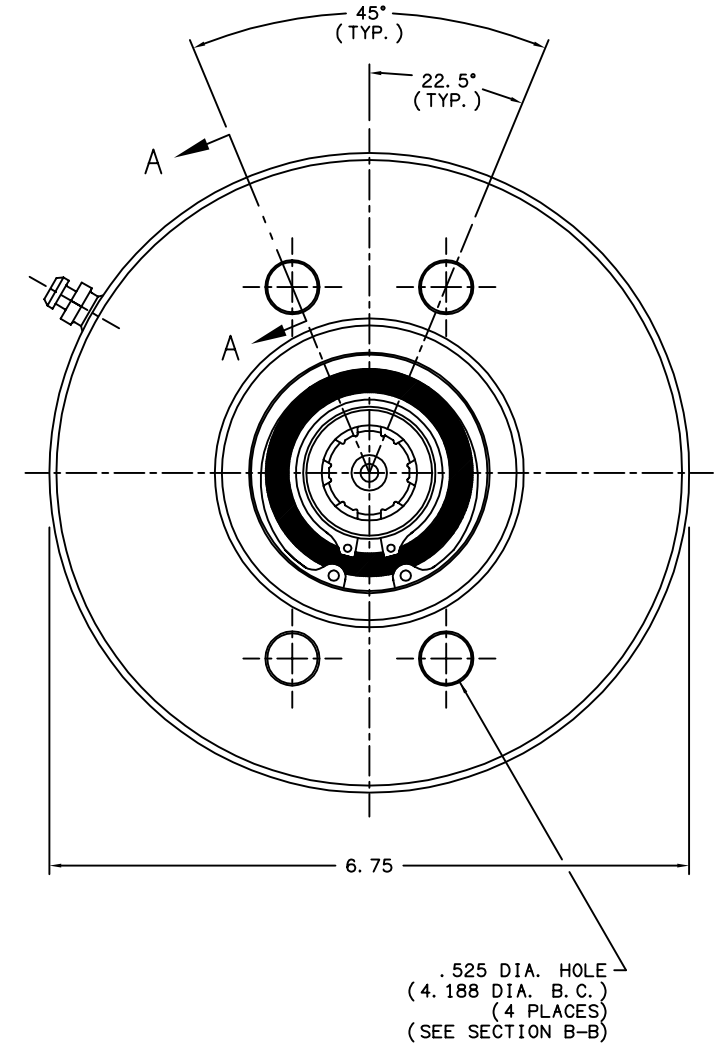
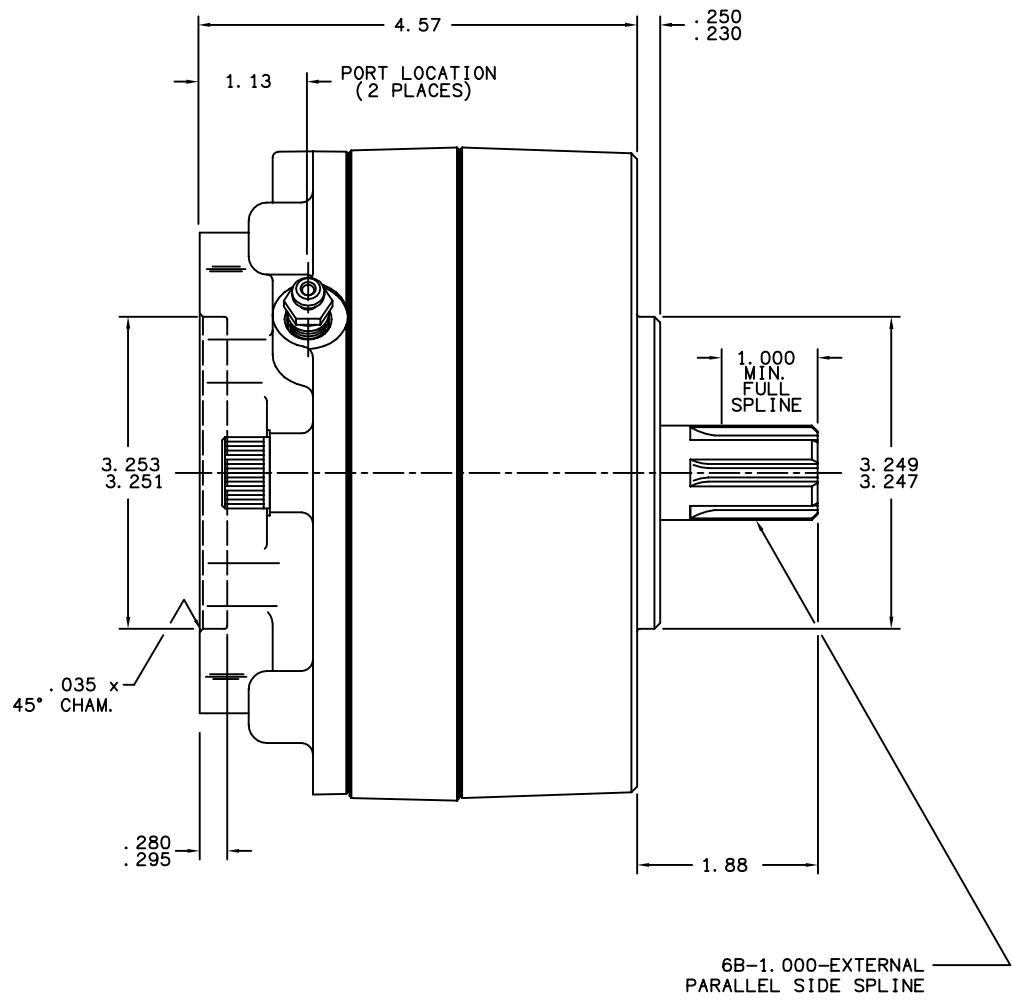
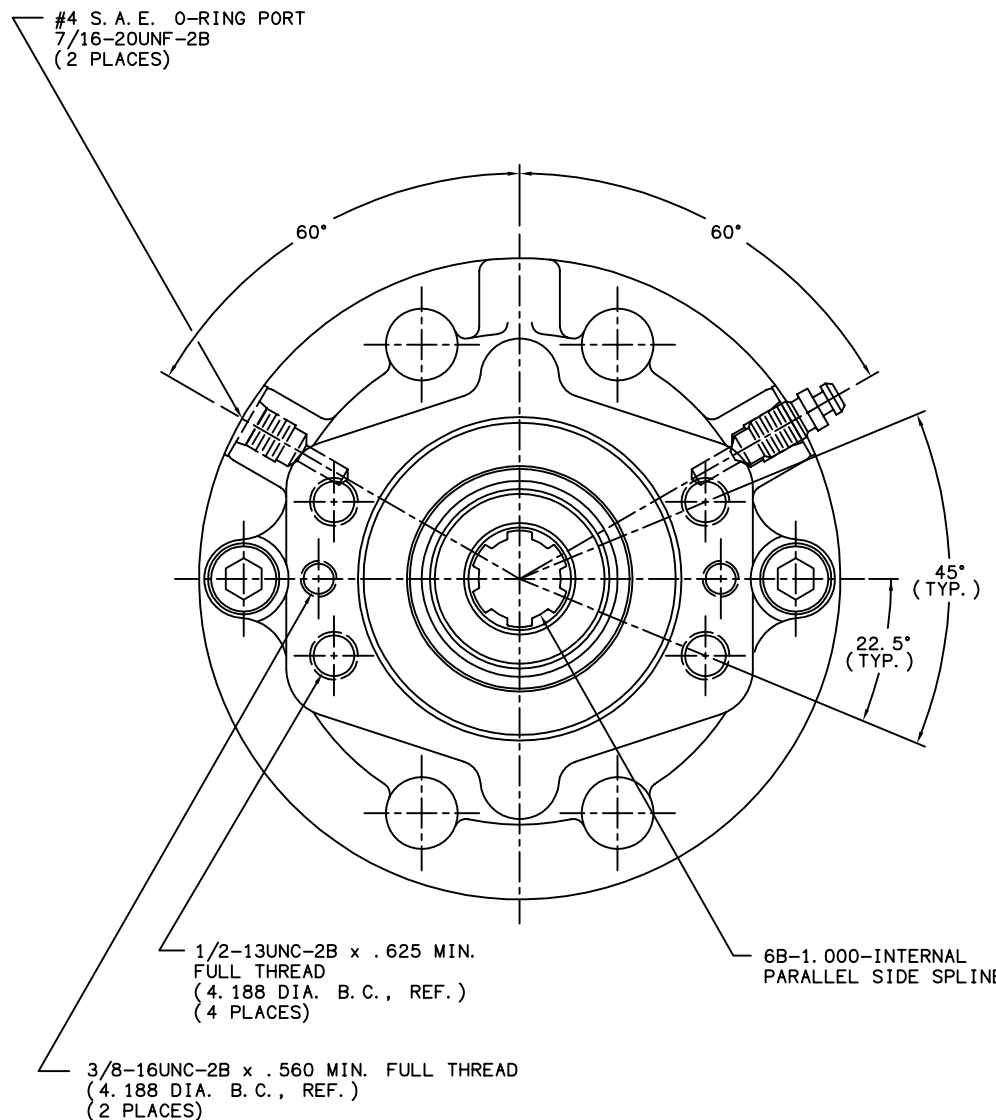

NOTES:

- 1) LINING REPAIR KIT P/N 12-501-245
- 2) BEARING REPAIR KIT P/N 12-501-241
- 3) O-RING REPAIR KIT P/N 12-501-246
- 4) SPRING REPAIR KIT P/N 12-501-244
- 5) REFER TO INSTALLATION SHEET #81-538-002 (SUPPLIED WITH BRAKE) FOR FURTHER MOUNTING INSTRUCTIONS.

SPECIFICATIONS:

TYPE:	DRY MULTIPLE DISC BRAKE, SPRING APPLY, HYDRAULIC RELEASE
TORQUE RATING:	4,000 LB-IN STATIC (BREAKAWAY) AT 0 PSI BACK PRESSURE
RELEASE PRESSURE:	210 PSI INITIAL, 250 PSI FULL
MAXIMUM OPERATING PRESSURE:	3,000 PSI
MAXIMUM SPEED:	3,900 RPM
LINING MATERIAL:	SINTERED BRONZE
APPROXIMATE WEIGHT:	27 LBS.
FOR USE WITH MINERAL BASE HYDRAULIC OIL ONLY	

MOUNTING HOLES FOR 1/2-13UNC SOCKET HEAD CAP SCREWS (SEE NOTE #5)

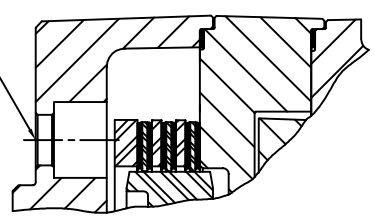

SECTION A-A

MICO, INC. CLAIMS PROPRIETARY RIGHTS TO THE MATERIAL DISCLOSED IN THIS DOCUMENT. THIS DOCUMENT IS PROVIDED IN CONFIDENCE AND MAY NOT BE REPRODUCED OR DISCLOSED WITHOUT WRITTEN PERMISSION FROM MICO, INC. COPYRIGHT MICO, INC. ALL RIGHTS RESERVED.

mico		North Mankato, Minnesota U.S.A.	
SCALE 1:2	PART NUMBER 13-538-064	REV. C	
X NO.	CUSTOMER COPY		
DRAWN G.J.			
REVISED LH			
DATE 06/30/99	CHECKED	APPROVED ENG.	