

TITLE MULTIPLE DISC BRAKE 3A-141439-M		PART NUMBER 13-538-050
REV.	NPR OR ECO NO.	DATE
E	ECN000131	07/06/06

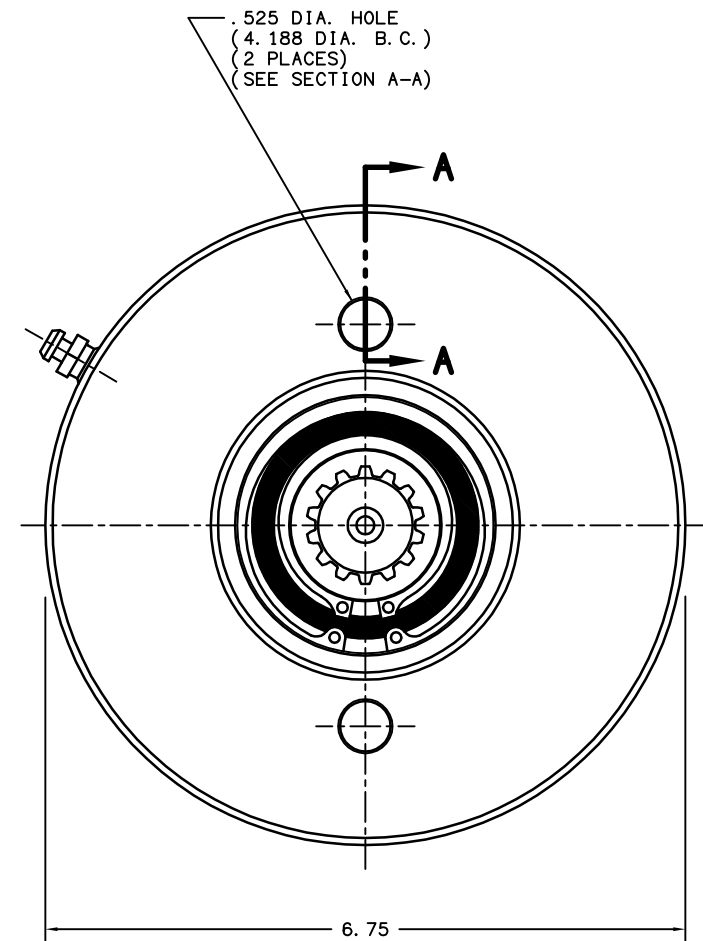
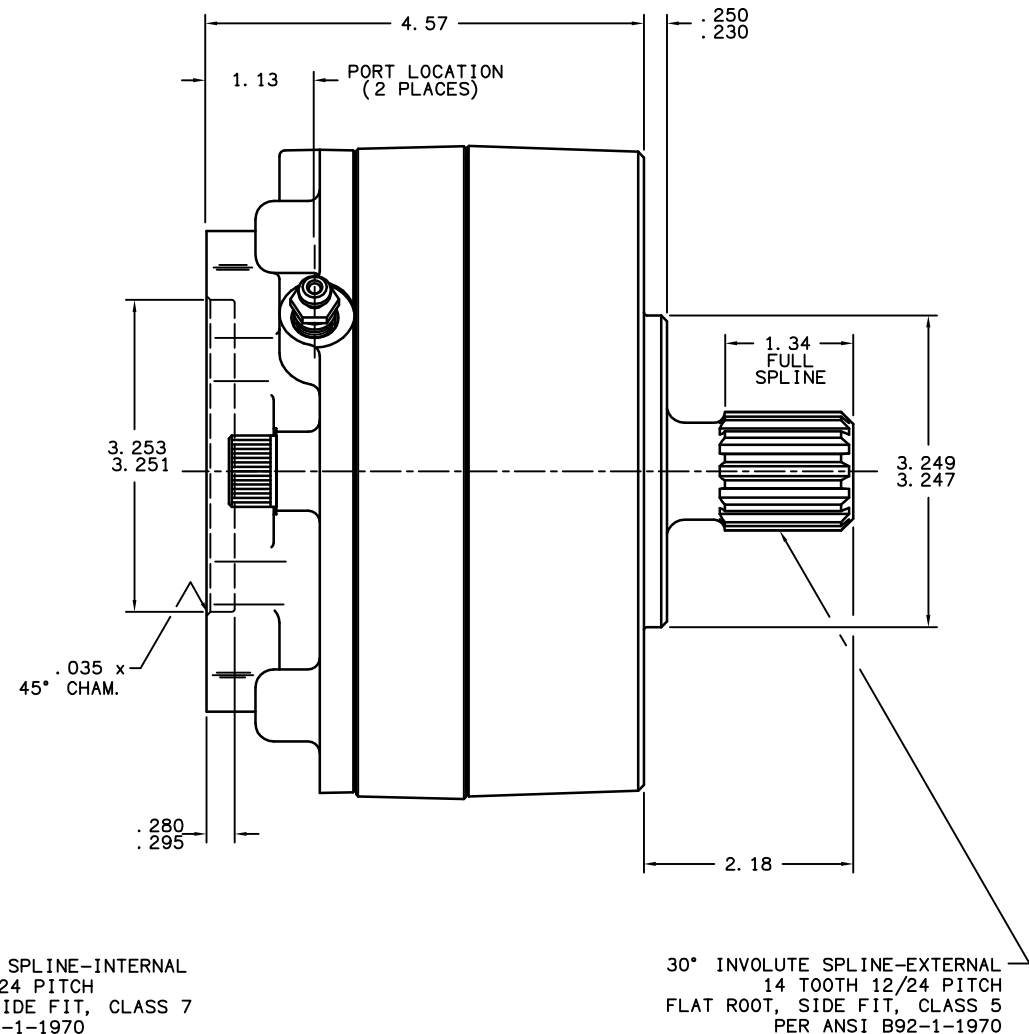
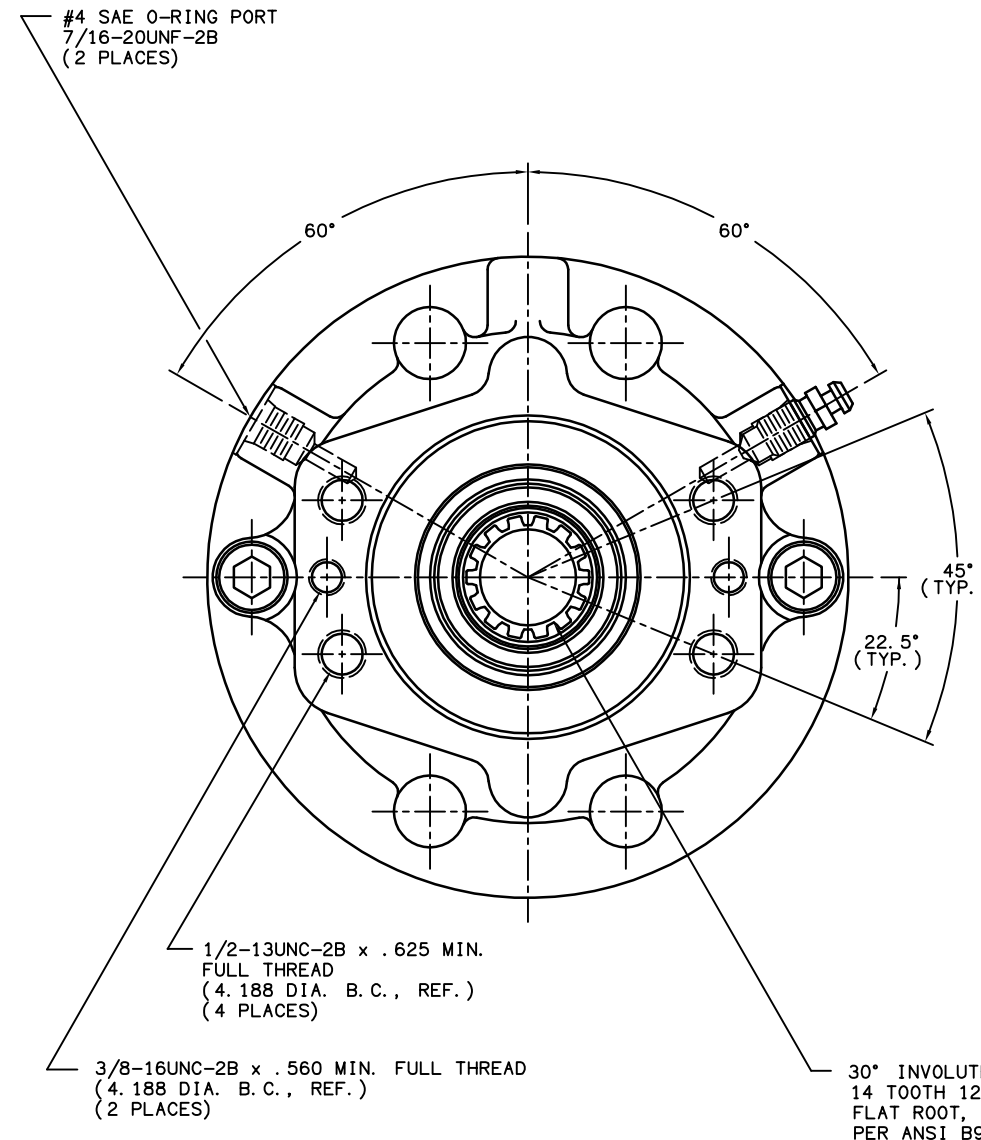

NOTES:

- 1) LINING REPAIR KIT P/N 12-501-243
- 2) BEARING REPAIR KIT P/N 12-501-242
- 3) O-RING REPAIR KIT P/N 12-501-246
- 4) SPRING REPAIR KIT P/N 12-501-244
- 5) REFER TO INSTALLATION SHEET #81-538-002 (SUPPLIED WITH BRAKE) FOR FURTHER MOUNTING INSTRUCTIONS.

SPECIFICATIONS:

TYPE: DRY MULTIPLE DISC BRAKE, SPRING APPLY, HYDRAULIC RELEASE

TORQUE RATING: 3,900 LB-IN STATIC (BREAKAWAY) AT 0 PSI BACK PRESSURE

RELEASE PRESSURE: 150 PSI INITIAL, 180 PSI FULL

MAXIMUM OPERATING PRESSURE: 3,000 PSI

MAXIMUM SPEED: 3,900 RPM

APPROXIMATE WEIGHT: 27 LBS.

FOR USE WITH MINERAL BASE HYDRAULIC OIL ONLY

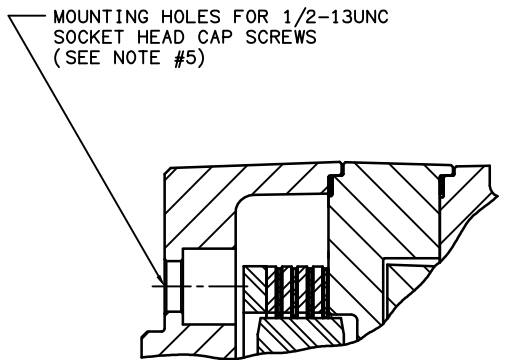

SECTION A-A

MICO, INC. CLAIMS PROPRIETARY RIGHTS TO THE MATERIAL DISCLOSED IN THIS DOCUMENT. THIS DOCUMENT IS PROVIDED IN CONFIDENCE AND MAY NOT BE REPRODUCED OR DISCLOSED WITHOUT WRITTEN PERMISSION FROM MICO, INC. COPYRIGHT MICO, INC. ALL RIGHTS RESERVED.

mico North Mankato, Minnesota U.S.A.	
SCALE 1:2	PART NUMBER 13-538-050
X NO.	REV. E
DRAWN G.J.	CUSTOMER COPY
REVISED A0	CHECKED
DATE 12/03/98	APPROVED ENG.