

PART NUMBER
13-538-040
NPI OR ECN NO.
ECO S-1729

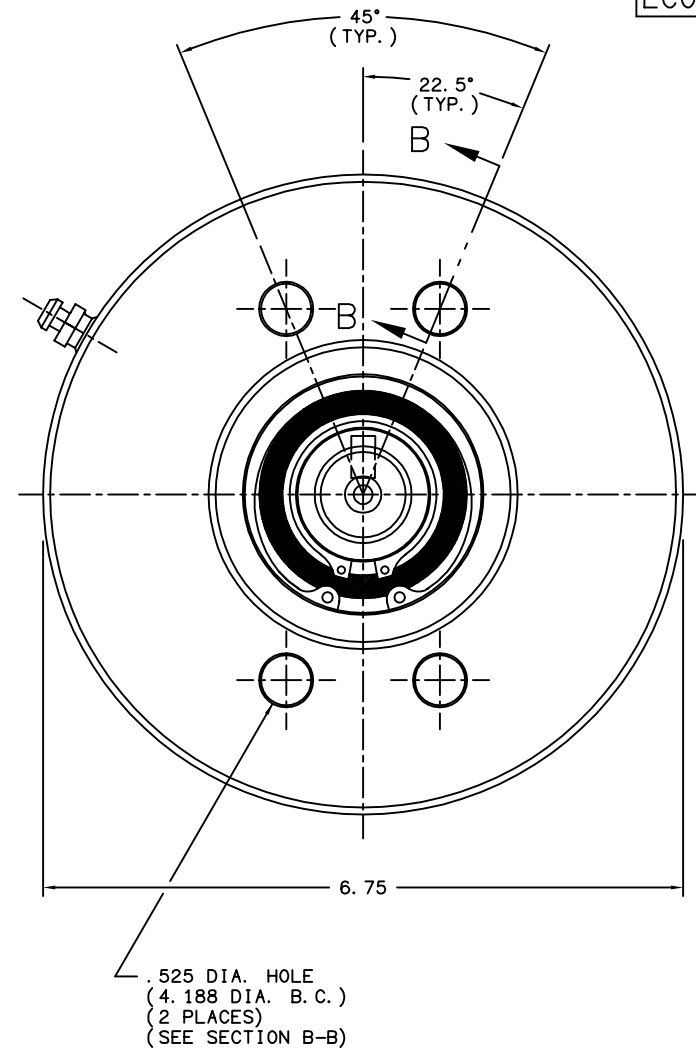
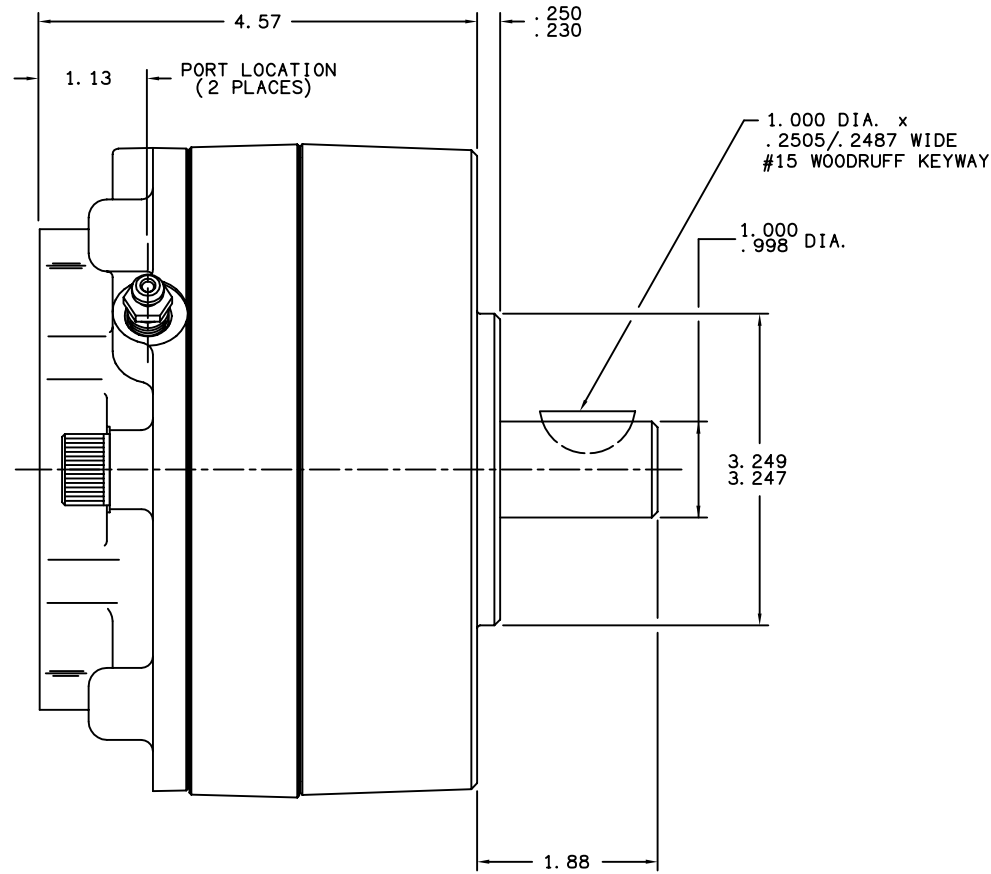
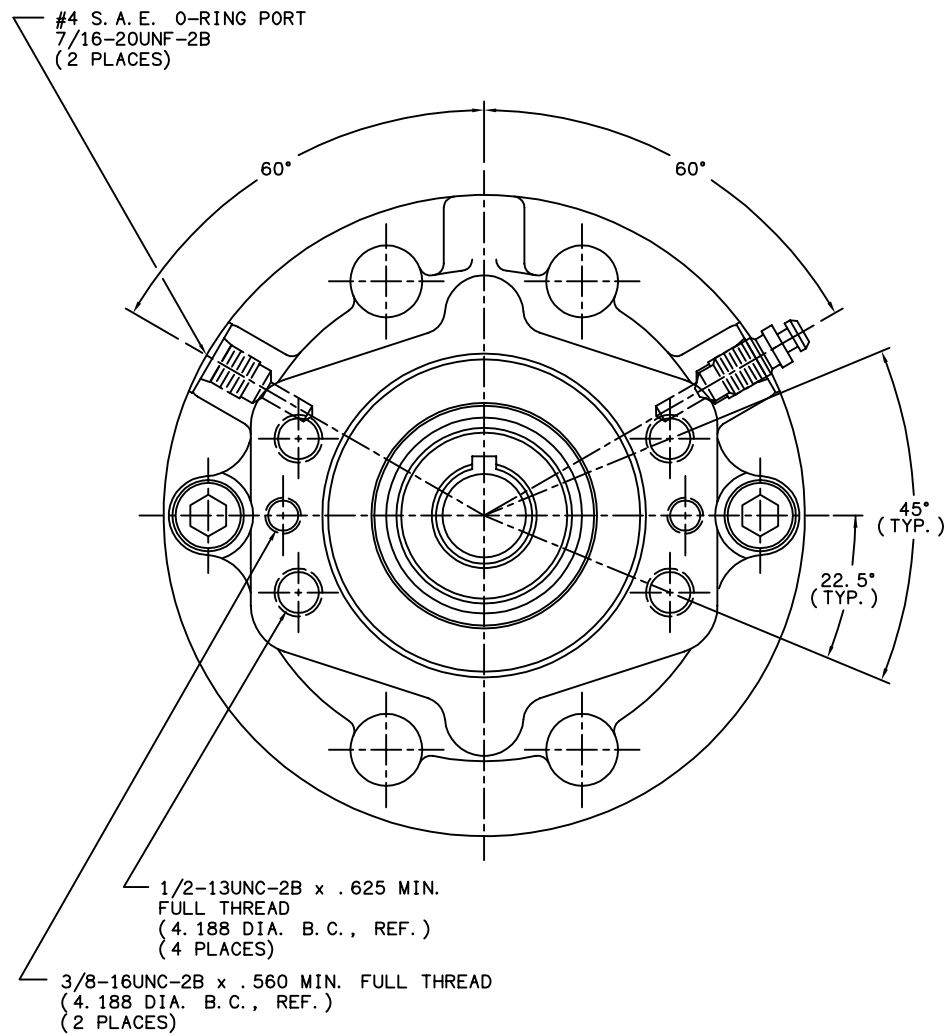

NOTES:

- 1) LINING REPAIR KIT P/N 12-501-245
- 2) BEARING REPAIR KIT P/N 12-501-241
- 3) O-RING REPAIR KIT P/N 12-501-246
- 4) SPRING REPAIR KIT P/N 12-501-244
- 5) REFER TO INSTALLATION SHEET #81-538-002 (SUPPLIED WITH BRAKE) FOR FURTHER MOUNTING INSTRUCTIONS.

SPECIFICATIONS:

TYPE: DRY MULTIPLE DISC BRAKE, SPRING APPLY, HYDRAULIC RELEASE

TORQUE RATING: 4,000 LB-IN STATIC (BREAKAWAY) AT 0 PSI BACK PRESSURE

RELEASE PRESSURE: 210 PSI INITIAL, 250 PSI FULL

MAXIMUM OPERATING PRESSURE: 3,000 PSI

MAXIMUM SPEED: 3,900 RPM

LINING MATERIAL: SINTERED BRONZE

APPROXIMATE WEIGHT: 27 LBS.

FOR USE WITH MINERAL BASE HYDRAULIC OIL ONLY

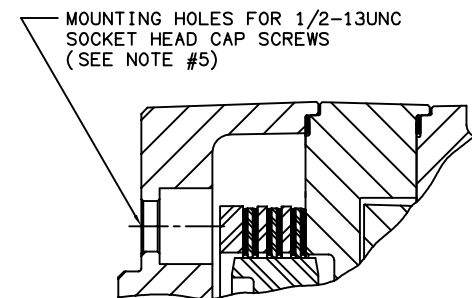

SECTION B-B



COMPONENT AND SYSTEM RECOMMENDATIONS MADE BY MICO, INC. ARE BASED ON INFORMATION SUPPLIED BY POTENTIAL USER AND/OR SYSTEM DESIGNER. THE POTENTIAL USER AND/OR DESIGNER MUST MAKE FINAL ACCEPTANCE AND APPROVAL OF COMPONENTS AND SYSTEM AFTER TESTING PERFORMANCE ON AN ACTUAL APPLICATION FOR WHICH SYSTEM WAS DESIGNED.		MICO, INC. CLAIMS PROPRIETARY RIGHTS TO THE MATERIAL DISCLOSED IN THIS DOCUMENT. THIS DOCUMENT IS PROVIDED IN CONFIDENCE AND MAY NOT BE REPRODUCED OR DISCLOSED WITHOUT WRITTEN PERMISSION FROM MICO, INC. COPYRIGHT MICO, INC. ALL RIGHTS RESERVED.	
TITLE MULTIPLE DISC BRAKE 3M-101040-M			
SCALE 1:2	CHECKED	PART NUMBER 13-538-040	REV C
DRN ETM 1-31-95	APP ENG	CUSTOMER COPY	