

TITLE MULTIPLE DISC BRAKE 3A-060618-M		PART NUMBER 13-538-004
REV.	NPR OR ECO NO.	DATE
D	ECN000131	07/05/06

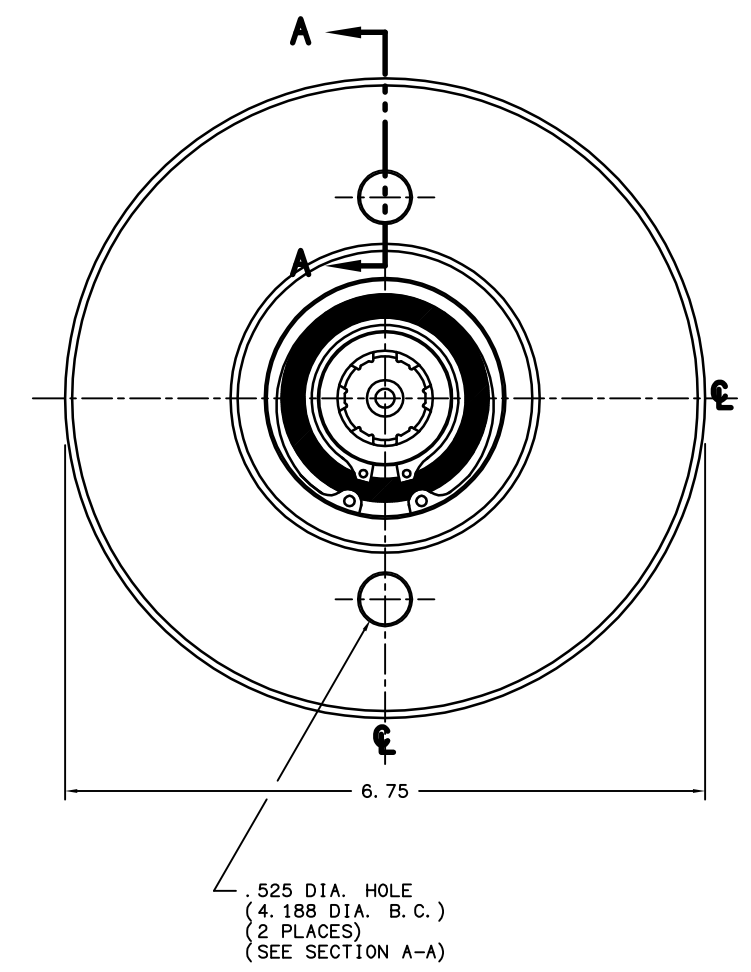
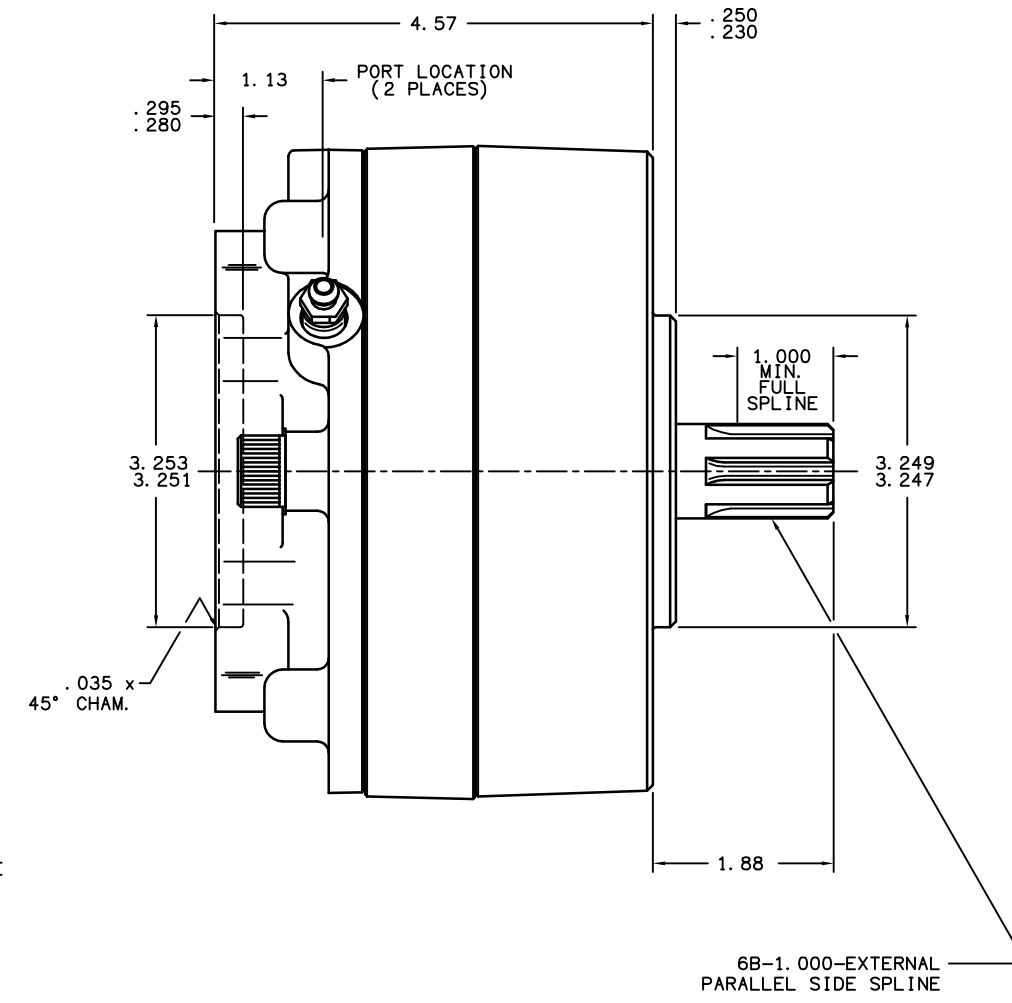
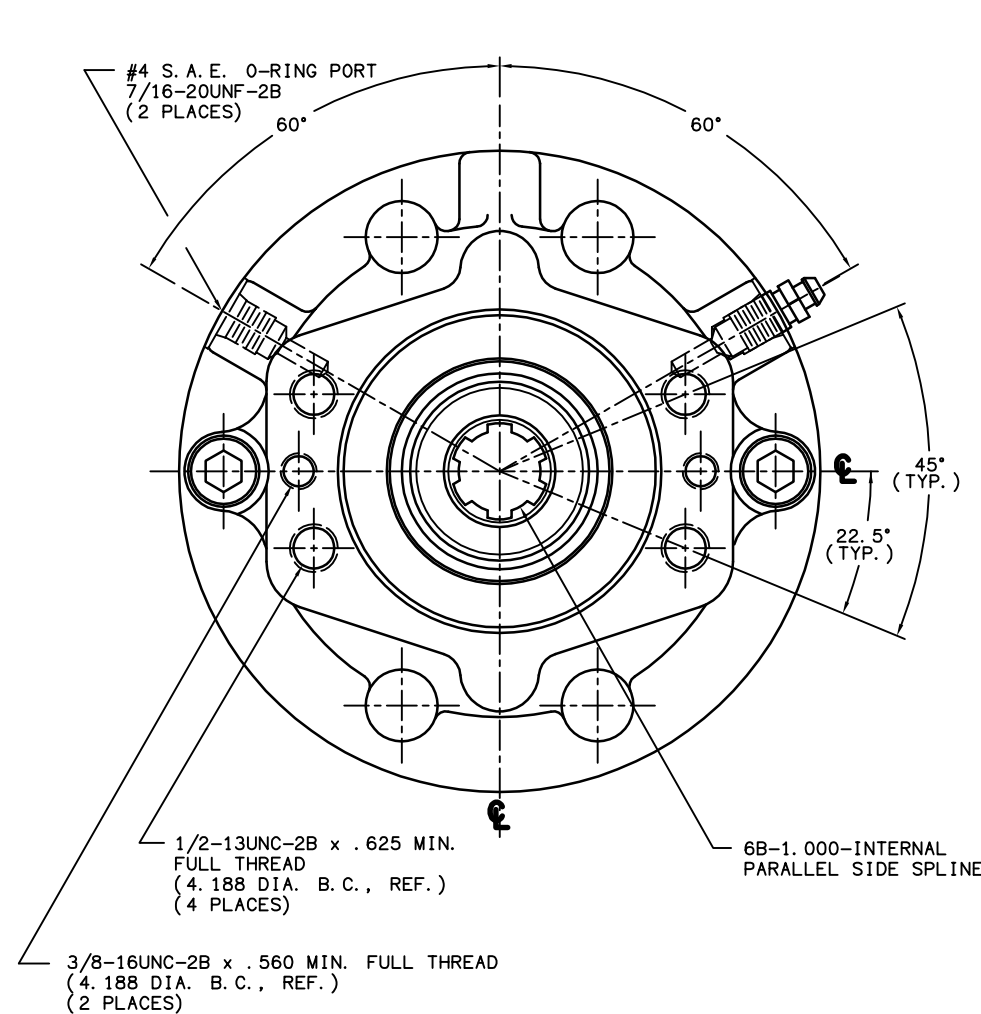

NOTES:

- 1) LINING REPAIR KIT P/N 12-501-245
- 2) BEARING REPAIR KIT P/N 12-501-241
- 3) O-RING REPAIR KIT P/N 12-501-246
- 4) SPRING REPAIR KIT P/N 12-501-244
- 5) REFER TO INSTALLATION SHEET #81-538-002 (SUPPLIED WITH BRAKE) FOR FURTHER MOUNTING INSTRUCTIONS.

SPECIFICATIONS:

TYPE: DRY MULTIPLE DISC BRAKE, SPRING APPLY, HYDRAULIC RELEASE

TORQUE RATING: 1,800 IN. LBS. STATIC (BREAKAWAY) AT 0 PSI BACK PRESSURE

RELEASE PRESSURE: 100 PSI INITIAL, 120 PSI FULL

MAXIMUM OPERATING PRESSURE: 3,000 PSI

MAXIMUM SPEED: 3,900 RPM

APPROXIMATE WEIGHT: 27 LBS.

FOR USE WITH MINERAL BASE HYDRAULIC OIL ONLY

MOUNTING HOLES FOR 1/2-13UNC SOCKET HEAD CAP SCREWS (SEE NOTE #5)

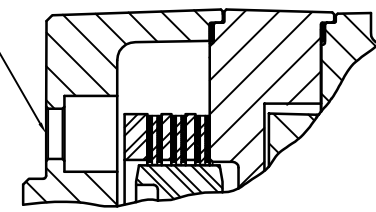

SECTION A-A

MICO, INC. CLAIMS PROPRIETARY RIGHTS TO THE MATERIAL DISCLOSED IN THIS DOCUMENT. THIS DOCUMENT IS PROVIDED IN CONFIDENCE AND MAY NOT BE REPRODUCED OR DISCLOSED WITHOUT WRITTEN PERMISSION FROM MICO, INC. COPYRIGHT MICO, INC. ALL RIGHTS RESERVED.

mico		North Mankato, Minnesota U. S. A.	
SCALE 1:2	PART NUMBER 13-538-004	REV. D	
X NO.	CUSTOMER COPY		
DRAWN G. J.			
REVISED A0			
DATE 03/16/99	CHECKED	APPROVED	ENG.