

TITLE		B-BRAKE CUSHMAN	PART NUMBER		13-100-038
REV.	NPR OR ECO NO.			DATE	
D	ECO S-1680			01/30/03	

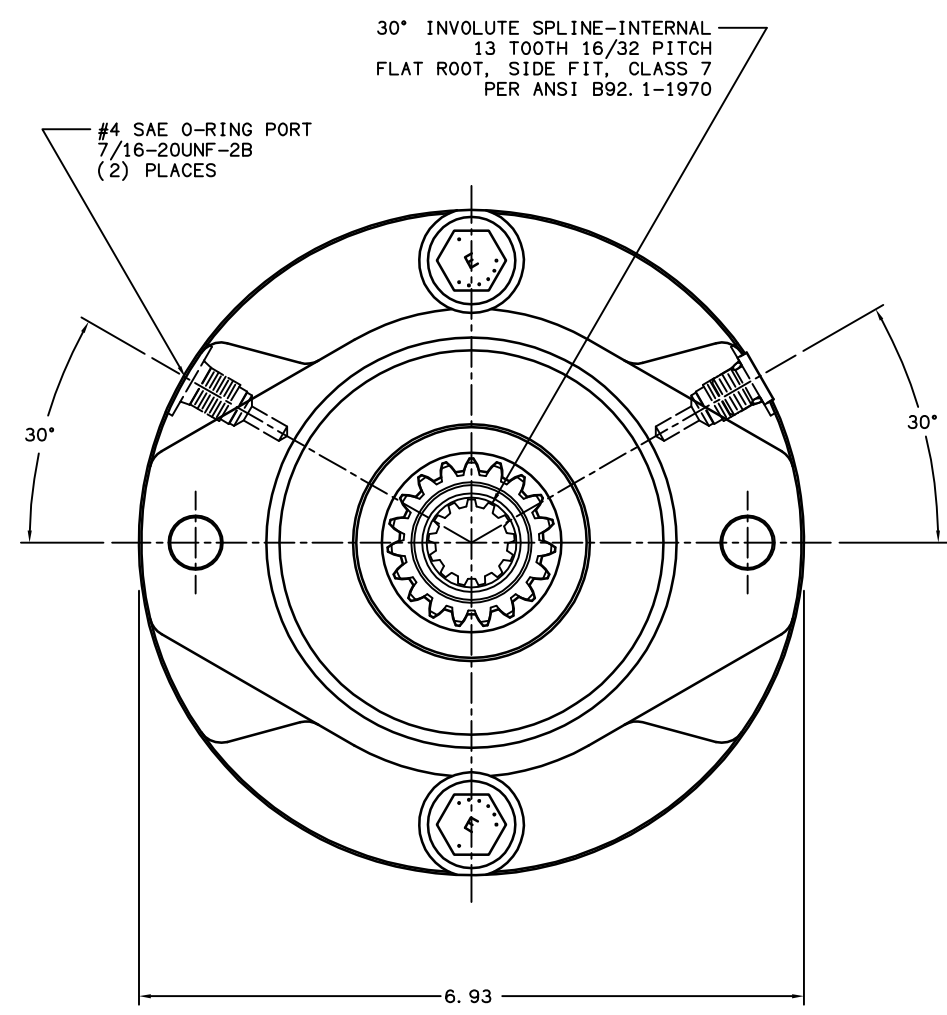
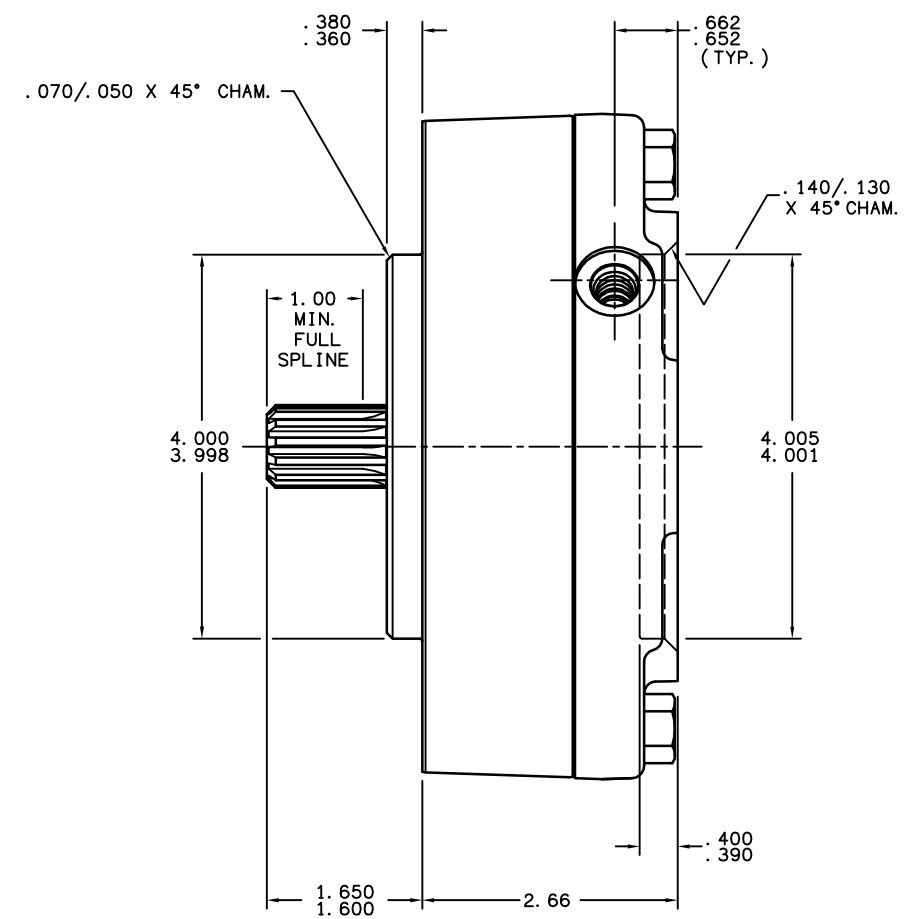
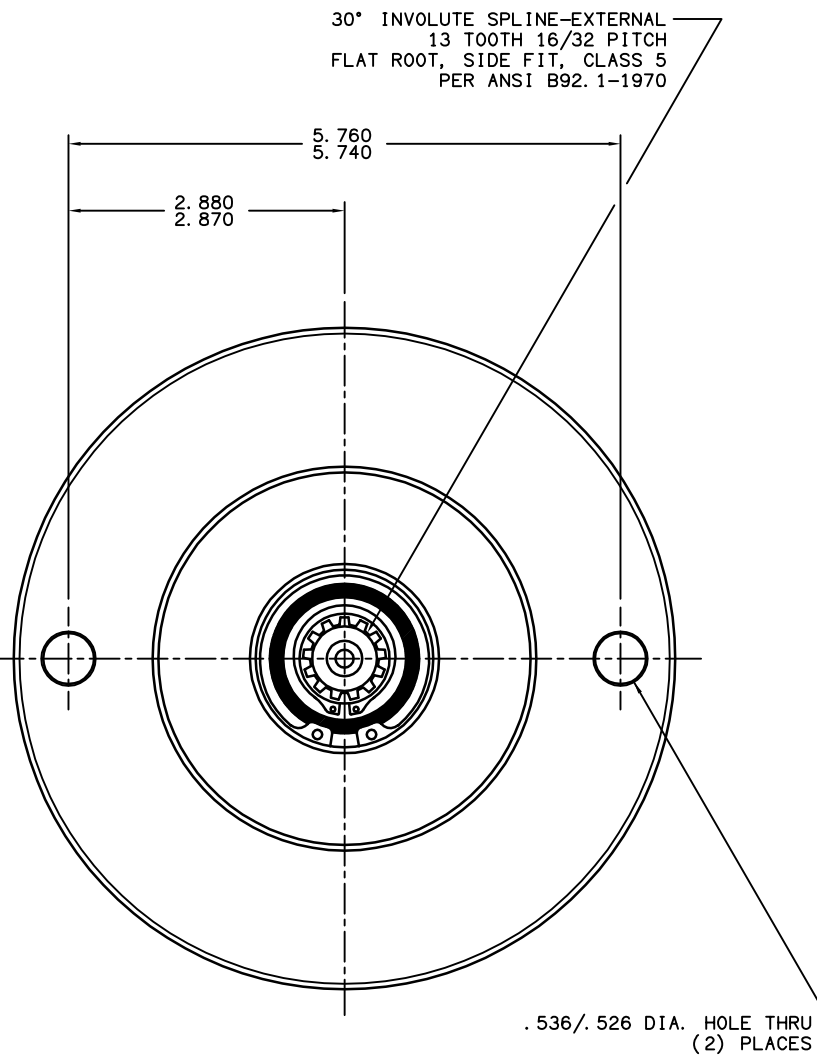

**NOTES:**

1) REPAIR KIT P/N 12-501-402

**SPECIFICATIONS:**

- TYPE:** SPRING APPLY, HYDRAULIC RELEASE
  - MAXIMUM SPEED:** 5,500 RPM SHAFT SPEED CAPABILITY SPECIFIED IS FOR BRAKE IN RELEASED CONDITION. ENERGY ABSORPTION DURING APPLY CYCLE MUST BE CAREFULLY EXAMINED FOR EACH APPLICATION.
  - RELEASE PRESSURE:** 290 PSI INITIAL, 340 PSI FULL, 3,000 PSI CONTINUOUS MAX. 4,000 PSI INTERMITTENT.
  - LINING MATERIAL:** HIGH PERFORMANCE COMPOSITE, NON-METALLIC BASED
  - TORQUE RATING:** 4,800 LB-IN STATIC (BREAKAWAY)
  - VOLUME OF OIL REQUIRED TO RELEASE BRAKE:** 0.5 IN.<sup>3</sup> MIN., 0.9 IN.<sup>3</sup> MAX.
  - APPROXIMATE WEIGHT:** 19 LBS.
- FOR USE WITH MINERAL BASE HYDRAULIC OIL ONLY.

MICO, INC. CLAIMS PROPRIETARY RIGHTS TO THE MATERIAL DISCLOSED IN THIS DOCUMENT. THIS DOCUMENT IS PROVIDED IN CONFIDENCE AND MAY NOT BE REPRODUCED OR DISCLOSED WITHOUT WRITTEN PERMISSION FROM MICO, INC. COPYRIGHT MICO, INC. ALL RIGHTS RESERVED.

<b>mico</b>		
North Mankato, Minnesota U.S.A.		
SCALE 1:2	PART NUMBER	REV.
X NO. X6752	13-100-038	D
DRAWN G.J.	CUSTOMER COPY	
REVISED GAA	DATE	CHECKED
	08/23/01	GJ 02/26/03
	APPROVED	ENG.KMM 02/26/03