

TITLE GOLD SERIES BRAKE		PART NUMBER 13-100-030	
REV.	NPR OR ECO NO.	DATE	
B	ECO S-1680	01/30/03	

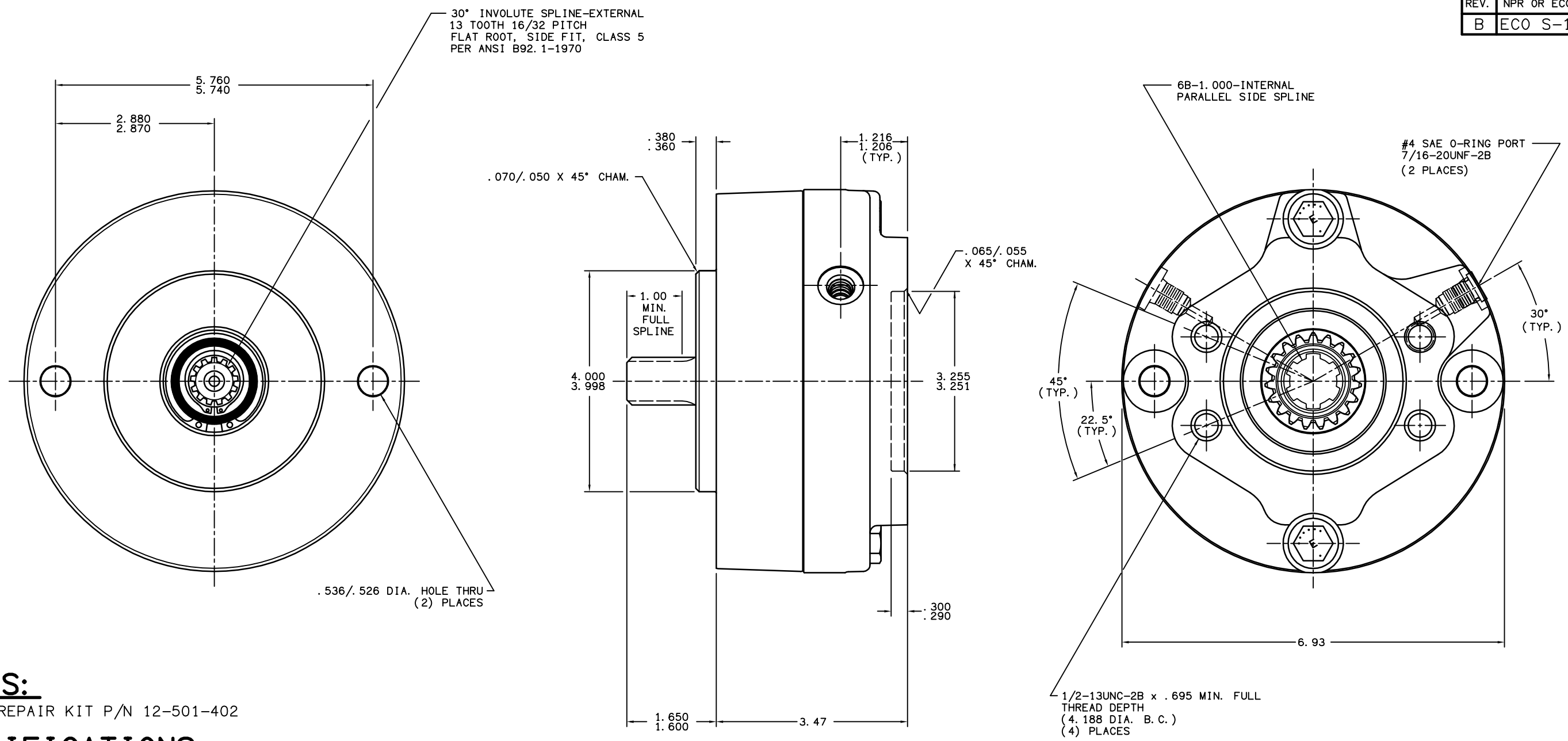

NOTES:

- 1) REPAIR KIT P/N 12-501-402

SPECIFICATIONS:

TYPE: SPRING APPLY, HYDRAULIC RELEASE

MAXIMUM SPEED: 4,000 RPM SHAFT SPEED CAPABILITY SPECIFIED IS FOR BRAKE IN RELEASED CONDITION. ENERGY ABSORPTION DURING APPLY CYCLE MUST BE CAREFULLY EXAMINED FOR EACH APPLICATION.

RELEASE PRESSURE: 250 PSI INITIAL, 290 PSI FULL, 3,000 PSI CONTINUOUS MAX. 4,000 PSI INTERMITTENT.

LINING MATERIAL: HIGH PERFORMANCE COMPOSITE, NON-METALLIC BASED

TORQUE RATING: 4,000 LB-IN STATIC (BREAKAWAY)

VOLUME OF OIL REQUIRED TO RELEASE BRAKE: 0.5 IN.³ MIN., 0.9 IN.³ MAX.

APPROXIMATE WEIGHT: 19 LBS.

FOR USE WITH MINERAL BASE HYDRAULIC OIL ONLY.

MICO, INC. CLAIMS PROPRIETARY RIGHTS TO THE MATERIAL DISCLOSED IN THIS DOCUMENT. THIS DOCUMENT IS PROVIDED IN CONFIDENCE AND MAY NOT BE REPRODUCED OR DISCLOSED WITHOUT WRITTEN PERMISSION FROM MICO, INC. COPYRIGHT MICO, INC. ALL RIGHTS RESERVED.

mico		North Mankato, Minnesota U.S.A.	
SCALE 1:2	PART NUMBER 13-100-030		REV.
X NO.	CUSTOMER COPY		B
DRAWN GAA	DATE 5/16/01	CHECKED GJ 02/26/03	APPROVED ENG.KMM 02/26/03