

DRAWING NUMBER
13-100-002
NPI OR ECN NO
ECN000329

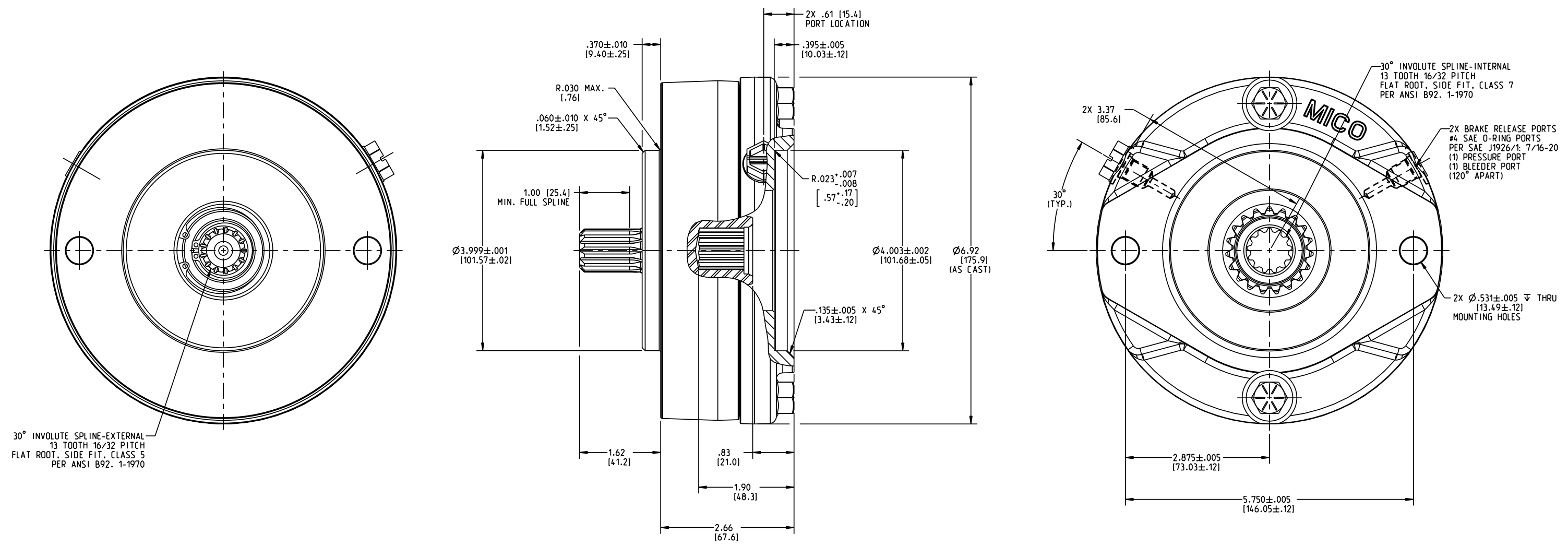

NOTES:

1. USE MINERAL BASE HYDRAULIC OIL ONLY FOR BRAKE RELEASE
2. DIMENSIONS MAY VARY BETWEEN UNITS AND ARE FOR REFERENCE PURPOSES ONLY. MILLIMETER VALUES MAY NOT BE AN EXACT CONVERSION OF INCH VALUES.
3. REPAIR KIT P/N 12-501-388

SPECIFICATIONS:

TYPE:	DRY MULTIPLE DISC BRAKE, SPRING APPLY, HYDRAULIC RELEASE
MAXIMUM SPEED:	4,000 RPM SHAFT SPEED CAPABILITY SPECIFIED IS FOR BRAKE IN RELEASED CONDITION. ENERGY ABSORPTION DURING APPLY CYCLE MUST BE CAREFULLY EXAMINED FOR EACH APPLICATION.
RELEASE PRESSURE:	100 PSI INITIAL, 115 PSI FULL, 3,000 PSI CONTINUOUS MAX. 4,000 PSI INTERMITTENT.
LINING MATERIAL:	HIGH PERFORMANCE COMPOSITE, NON-METALLIC BASED
TORQUE RATING:	1,200 LBIN STATIC (BREAKAWAY)
VOLUME OF OIL REQUIRED TO RELEASE BRAKE:	0.5 IN ³ MIN., 0.9 IN ³ MAX.
APPROXIMATE WEIGHT:	19 LB

**INCH
(MILLIMETER)**

MICO[®]
North Mankato, Minnesota USA

SCALE 0.500	TITLE B-MOUNT MULTIPLE DISC BRAKE COMPACT DESIGN	SIZE B	DRAWING NUMBER 13-100-002	REV H
DWN RGS1 2010-10-13	APVD PROD ENGR PJS 2011-03-18		CUSTOMER COPY	
X NO X6573-70	APVD ENGR RV 2011-03-02			

COMPONENT AND SYSTEM RECOMMENDATIONS MADE BY MICO, INC ARE BASED ON INFORMATION SUPPLIED BY POTENTIAL USER AND/OR SYSTEM DESIGNER. THE POTENTIAL USER AND/OR DESIGNER MUST MAKE FINAL ACCEPTANCE AND APPROVAL OF COMPONENTS AND SYSTEM AFTER TESTING PERFORMANCE ON AN ACTUAL APPLICATION FOR WHICH SYSTEM WAS DESIGNED.

MICO, INC CLAIMS PROPRIETARY RIGHTS TO THE MATERIAL DISCLOSED IN THIS DOCUMENT. THIS DOCUMENT IS PROVIDED IN CONFIDENCE AND MAY NOT BE REPRODUCED OR DISCLOSED WITHOUT WRITTEN PERMISSION FROM MICO, INC. COPYRIGHT MICO, INC. ALL RIGHTS RESERVED.