

DETAIL A
SCALE 1.000

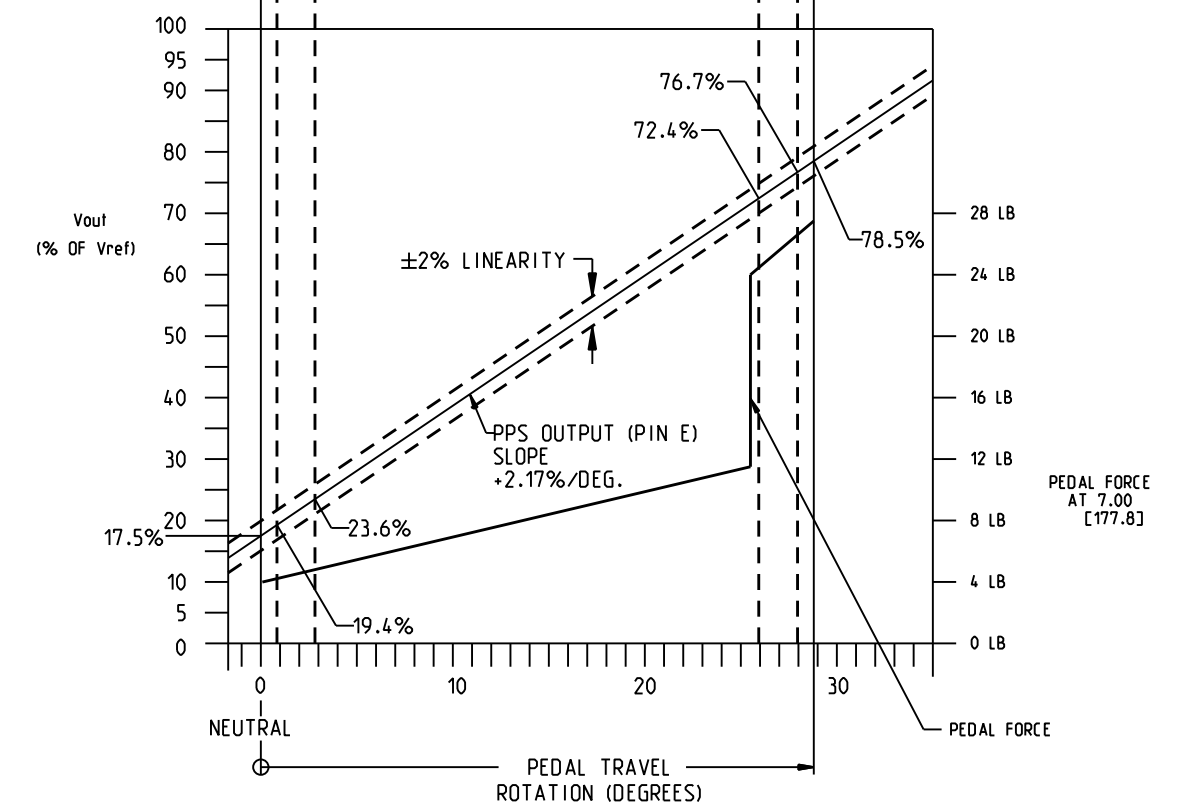

CURVE SHOWN FOR PIN D HIGH. REVERSING VREF REVERSES THE CURVE.

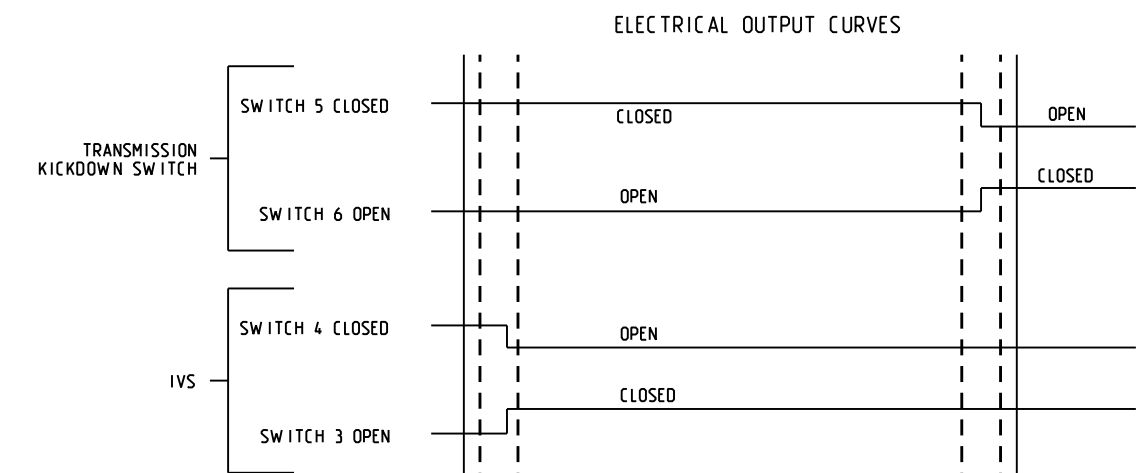
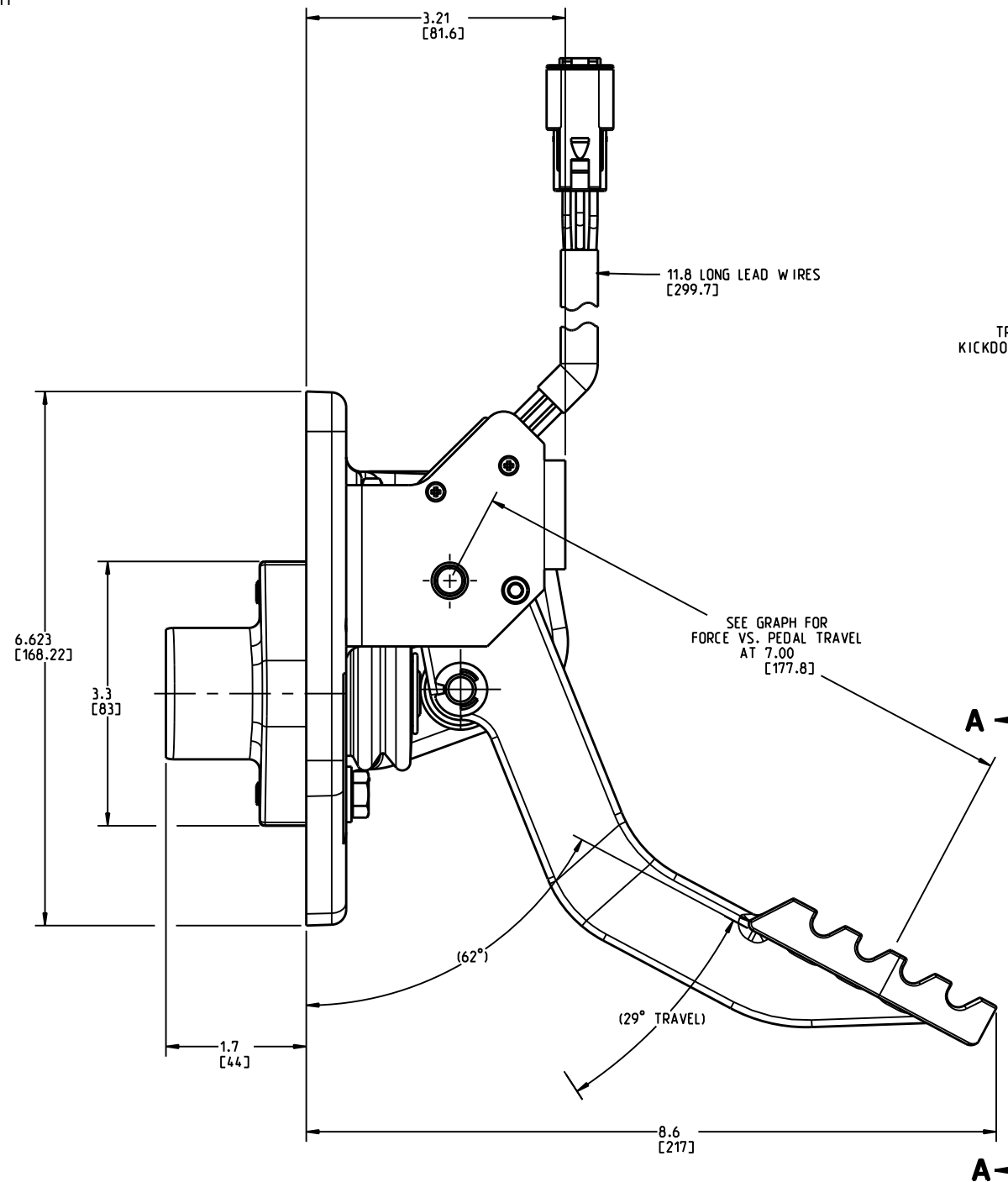
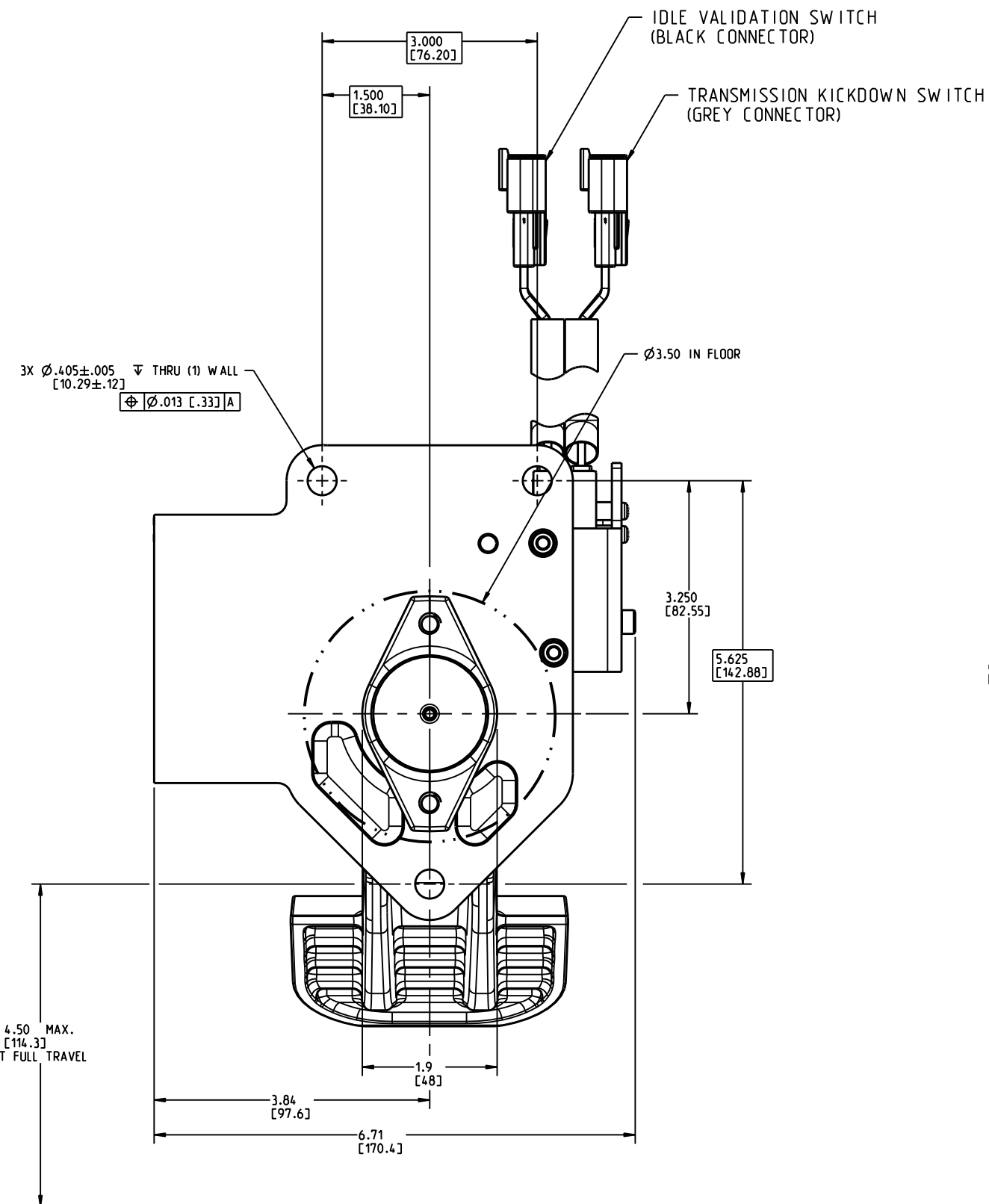
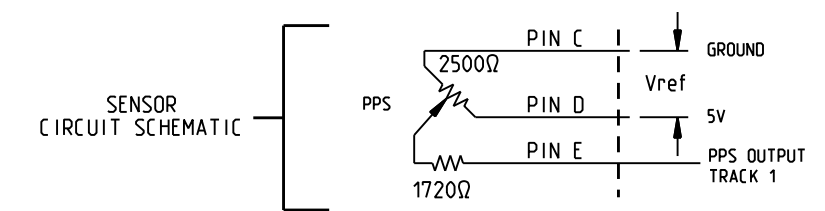
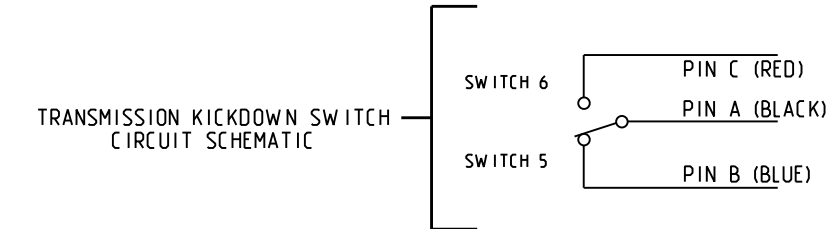
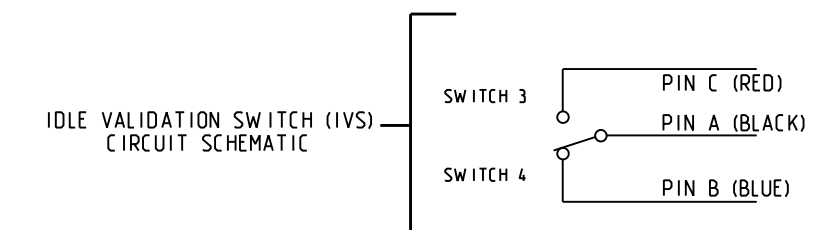
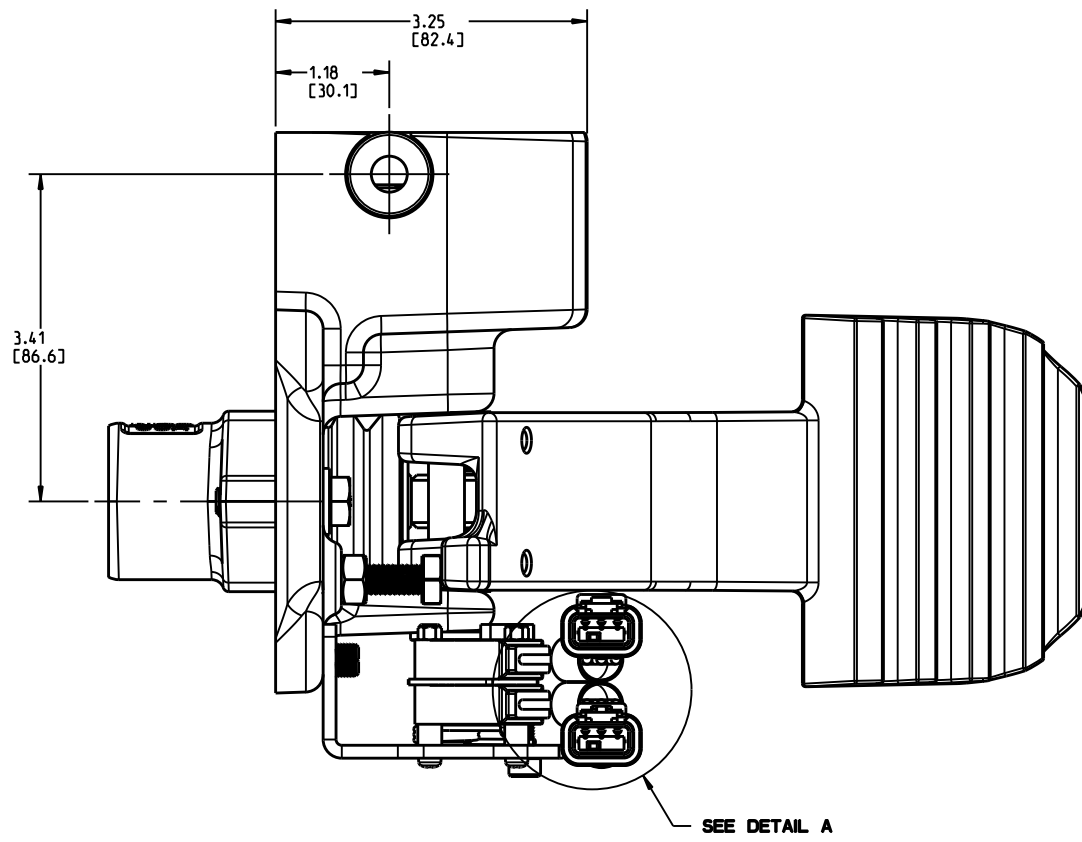
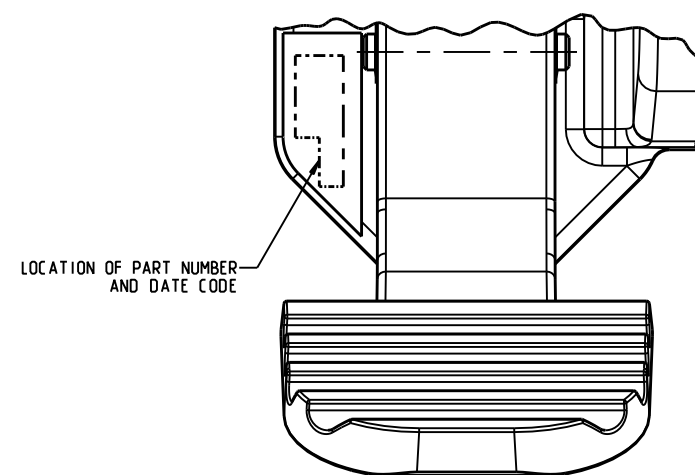

VIEW A-A

NOTES:

- 1) DIMENSIONS MAY VARY BETWEEN UNITS AND ARE FOR REFERENCE PURPOSES ONLY. MILLIMETER VALUES MAY NOT BE AN EXACT CONVERSION OF INCH VALUES.
- 2) SUPPLY VOLTAGE 28V MAX. 5V TYPICAL.
- 3) PEDAL ANGLE SENSOR:
 - A) MATING CONNECTOR: DELPHI METRI-PACK 10 PIN (2X5) P/N 12065425 OR EQUIVALENT WITH TIN PLATED TERMINALS.
 - B) MAXIMUM CURRENT DRAW: 5.0 mA EACH CIRCUIT OR .08 WATT MAXIMUM.
 - C) OVERALL RESISTANCE AND SERIES WIPER RESISTANCE TOLERANCE: ±30%.
- 4) IDLE VALIDATION SWITCH: (BLACK CONNECTOR)
 - A) MATING CONNECTOR: DEUTSCH DT SERIES P/N DTM06-3S-GOLD PLATED CONTACTS.
 - B) ELECTRICAL DATA: 5 AMP RESISTIVE - 30VDC
.2 AMP RESISTIVE - 250VDC
- 5) TRANSMISSION KICKDOWN SWITCH: (GREY CONNECTOR)
 - A) MATING CONNECTOR: DEUTSCH DT SERIES P/N DTM06-3S-GOLD PLATED CONTACTS.
 - B) ELECTRICAL DATA: 5 AMP RESISTIVE - 30VDC
.2 AMP RESISTIVE - 250 VDC
- 6) REPAIR KIT FOR LIMIT SWITCHES P/N: 06-400-467.
- 7) WEIGHT: 5.4 LB (2.4 KG)
- 8) SURFACE FINISH: PEDAL & BASE ARE BLACK ANODIZED ALUMINUM.

INCH
[MILLIMETER]



COMPONENT AND SYSTEM RECOMMENDATIONS MADE BY MICO, INC ARE BASED ON INFORMATION SUPPLIED BY POTENTIAL USER AND/OR SYSTEM DESIGNER. THE POTENTIAL USER AND/OR DESIGNER MUST MAKE FINAL ACCEPTANCE AND APPROVAL OF COMPONENTS AND SYSTEM AFTER TESTING PERFORMANCE ON AN ACTUAL APPLICATION FOR WHICH SYSTEM WAS DESIGNED.		MICO, INC CLAIMS PROPRIETARY RIGHTS TO THE MATERIAL DISCLOSED IN THIS DOCUMENT. THIS DOCUMENT IS PROVIDED IN CONFIDENCE AND MAY NOT BE REPRODUCED OR DISCLOSED WITHOUT WRITTEN PERMISSION FROM MICO, INC. COPYRIGHT MICO, INC. ALL RIGHTS RESERVED.	
SCALE 0.500	TITLE EPK-S62-RJ-NA030-010	SIZE C	DRAWING NUMBER 07-910-016
DWN ETM 2013-05-06	APVD ENGRG MH 2013-05-28	CUSTOMER COPY	REV F
X NO X7784-75	APVD ENGRG PWB 2013-05-07		