

EBV-M BRAKE PRESSURE VS CURRENT

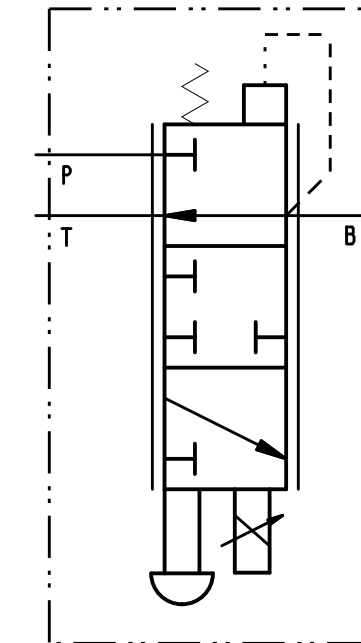
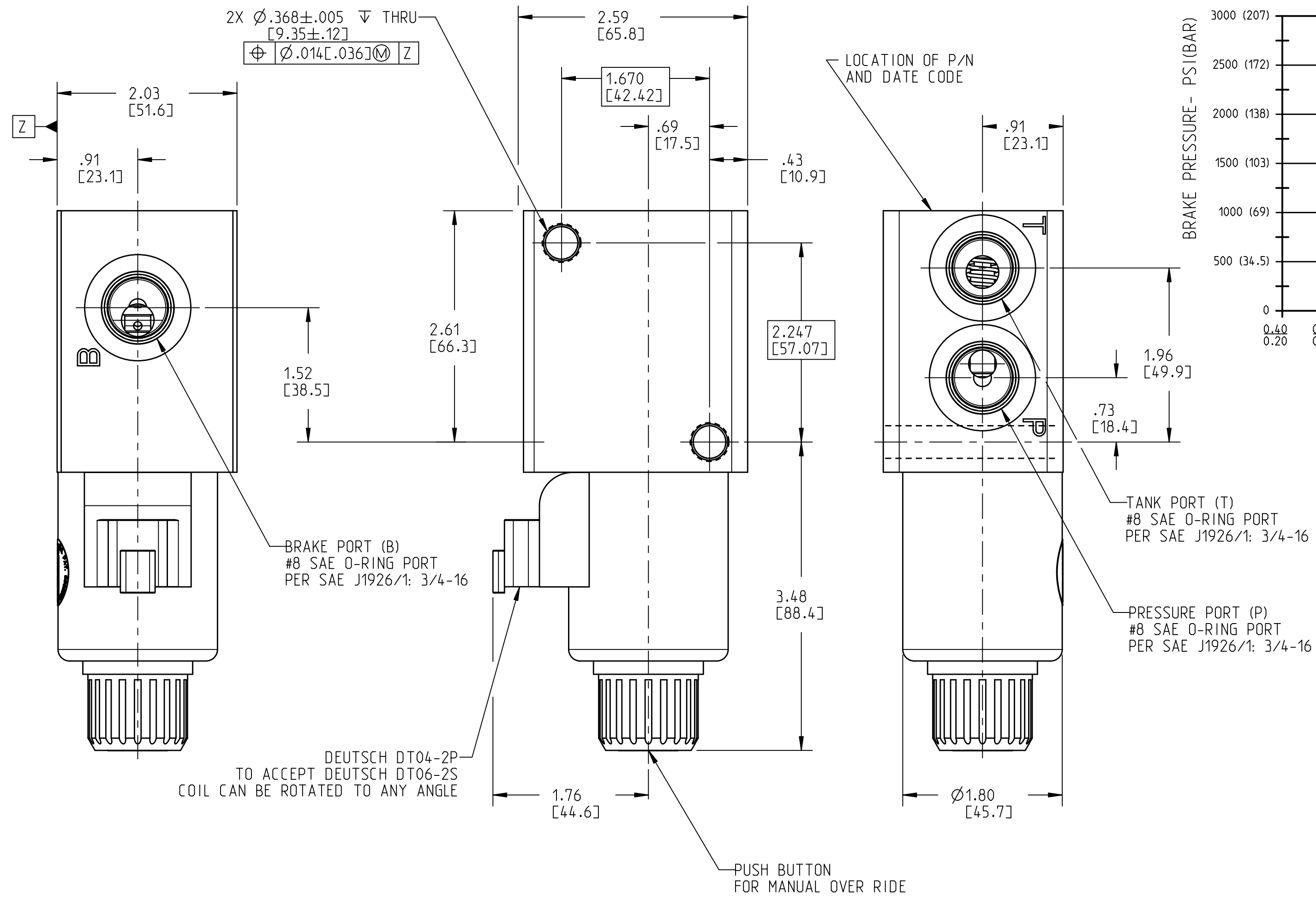
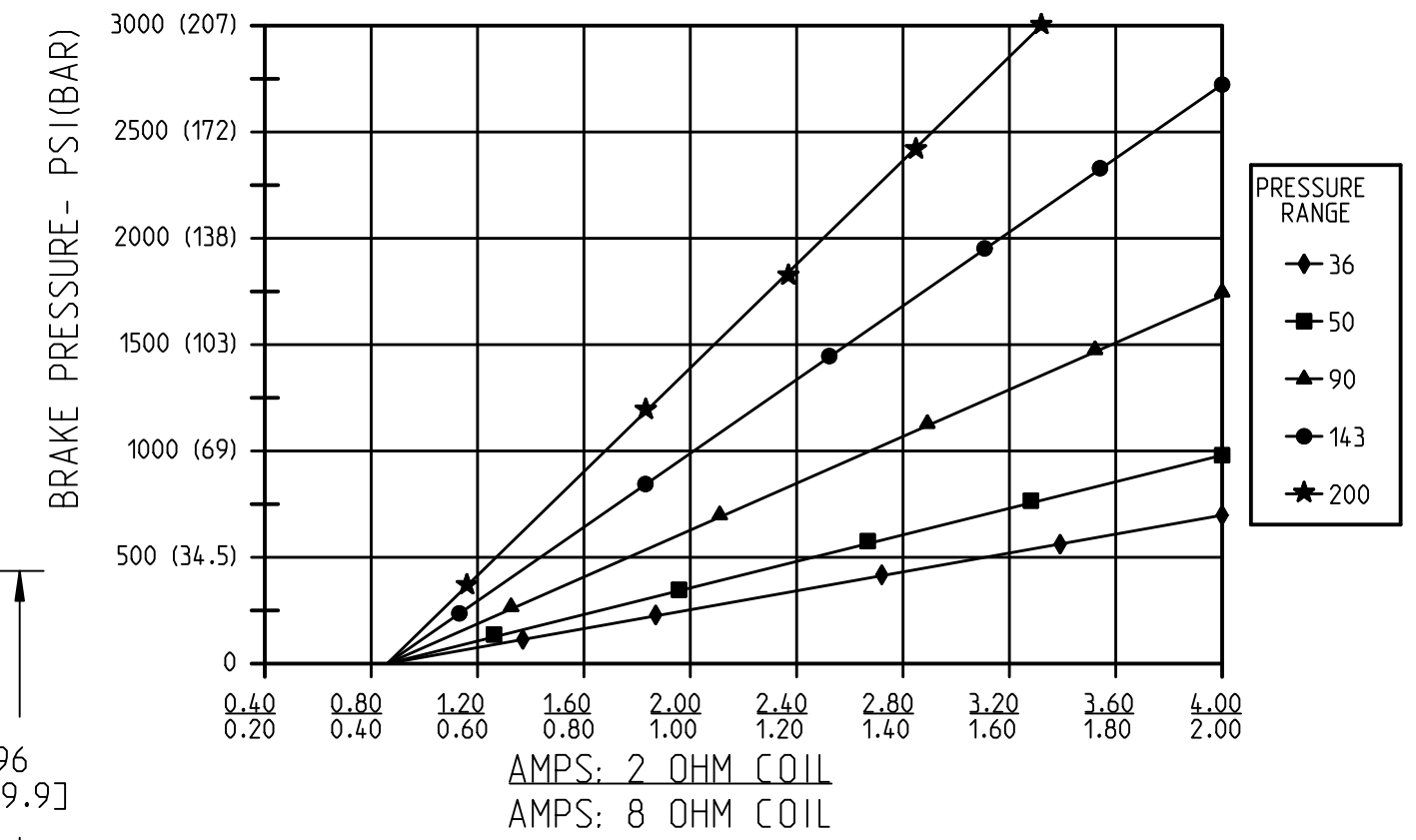

NOTES:

- TO BE USED WITH MINERAL BASE HYDRAULIC OIL ONLY (NITRILE SEALS).
- DIMENSIONS MAY VARY BETWEEN UNITS AND ARE REFERENCE PURPOSES ONLY. MILLIMETER VALUES MAY NOT BE AN EXACT CONVERSION OF INCH VALUES.
- ∇ RECOMMENDED MINIMUM DITHER AMPLITUDE.
- MAX LEAKAGE IS 32 CC/MIN AT 2000 PSI (138 BAR) AND 150 SUS (32 CST).
- RATED PRESSURE AT (P) AND (B) PORTS IS 3000 PSI (207 BAR).
- SURFACE COATING: OLIVE DRAB PRIMER PER DOD-P-15328 SPECIFICATION.
- WEIGHT IS 4.7 LB (2.1 KG).
- REPAIR KIT NOT REQUIRED.
- RATED IP67 (TEMPORARY SUBMERSION) PER EN 60529.
- TEMPERATURE RANGE FOR 100% DUTY CYCLE IS -50 °C TO 60 °C. LESS THAN 100% DUTY CYCLE CAN RUN HIGHER AMBIENT AIR TEMPERATURES.

PRODUCT #	MODEL CODE	COIL OHMS AT 77°F (25°C)	∇ DITHER A AC	MINIMUM FULL ON BRAKE PRESSURE PSI (BAR)	MAXIMUM 100% DUTY CYCLE FULL ON BRAKE PRESSURE PSI (BAR)
07-100-013	EBV-M-MS08N-D024-RN-36-21	8.0	.12	290 (20)	520 (35)
07-100-014	EBV-M-MS08N-D024-RN-50-21	8.0	.12	400 (28)	730 (50)
07-100-015	EBV-M-MS08N-D024-RN-90-21	8.0	.12	710 (49)	1310 (90)
07-100-016	EBV-M-MS08N-D024-RN-143-21	8.0	.12	1130 (78)	2070 (143)
07-100-017	EBV-M-MS08N-D024-RN-200-21	8.0	.12	1590 (110)	2900 (200)
07-100-018	EBV-M-MS08N-D012-RN-36-21	2.0	.24	290 (20)	520 (35)
07-100-019	EBV-M-MS08N-D012-RN-50-21	2.0	.24	400 (28)	730 (50)
07-100-020	EBV-M-MS08N-D012-RN-90-21	2.0	.24	710 (49)	1310 (90)
07-100-021	EBV-M-MS08N-D012-RN-143-21	2.0	.24	1130 (78)	2070 (143)
07-100-022	EBV-M-MS08N-D012-RN-200-21	2.0	.24	1590 (110)	2900 (200)

US PAT 6802330

INCH
(MILLIMETER)



COMPONENT AND SYSTEM RECOMMENDATIONS MADE BY MICO, INC ARE BASED ON INFORMATION SUPPLIED BY POTENTIAL USER AND/OR SYSTEM DESIGNER. THE POTENTIAL USER AND/OR DESIGNER MUST MAKE FINAL ACCEPTANCE AND APPROVAL OF COMPONENTS AND SYSTEM AFTER TESTING PERFORMANCE ON AN ACTUAL APPLICATION FOR WHICH SYSTEM WAS DESIGNED.		MICO, INC CLAIMS PROPRIETARY RIGHTS TO THE MATERIAL DISCLOSED IN THIS DOCUMENT. THIS DOCUMENT IS PROVIDED IN CONFIDENCE AND MAY NOT BE REPRODUCED OR DISCLOSED WITHOUT WRITTEN PERMISSION FROM MICO, INC. COPYRIGHT MICO, INC. ALL RIGHTS RESERVED.		SCALE 1.000	TITLE EBV-M-MS08N	SIZE C	DRAWING NUMBER 07-100-002	REV 3
DWN JJC 2012-01-18		APVD ENGRG STR 2015-11-23		X NO 7214		CUSTOMER COPY		