



NOTES:

1. TO BE USED WITH MINERAL BASE HYDRAULIC OIL ONLY.
2. DIMENSIONS MAY VARY SLIGHTLY BETWEEN UNITS AND ARE TO BE USED FOR REFERENCE PURPOSES ONLY. MILLIMETER VALUES MAY NOT BE AN EXACT CONVERSION OF INCH VALUES.
3. VALVE ASSEMBLY P/N 20-100-855.
4. BOOT KIT P/N 06-400-126.
5. VALVE REPAIR KIT P/N 06-400-113.
6. SURFACE FINISH: OLIVE DRAB PRIMER PER DOD-P-15328 SPECIFICATION.

SWITCH RATINGS

1. 4 AMP AT 30 VDC INDUCTIVE LOAD.
2. 5 AMP AT 30 VDC RESISTIVE LOAD.

PERFORMANCE CHARACTERISTICS:

1. BRAKE PRESSURE SETTING IS 870 ±75 PSI.
2. PRESSURE FROM UPPER BRAKE PORT IS APPROXIMATELY 45 PSI HIGHER THAN PRESSURE FROM LOWER BRAKE PORT.
3. 800 PSI MINIMUM IS REQUIRED TO FULLY APPLY PILOTED SECTION.

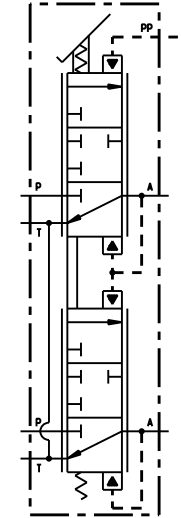
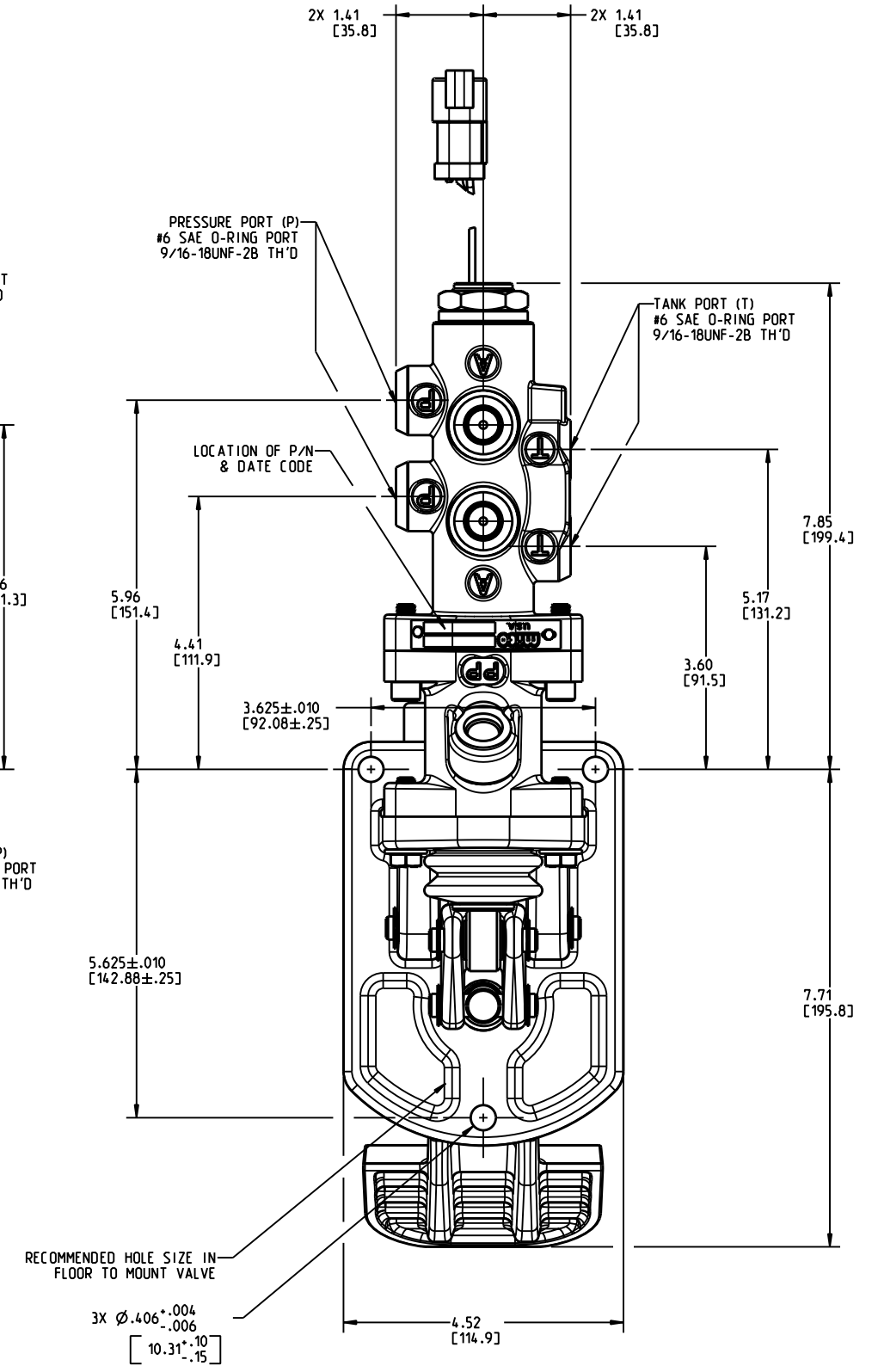
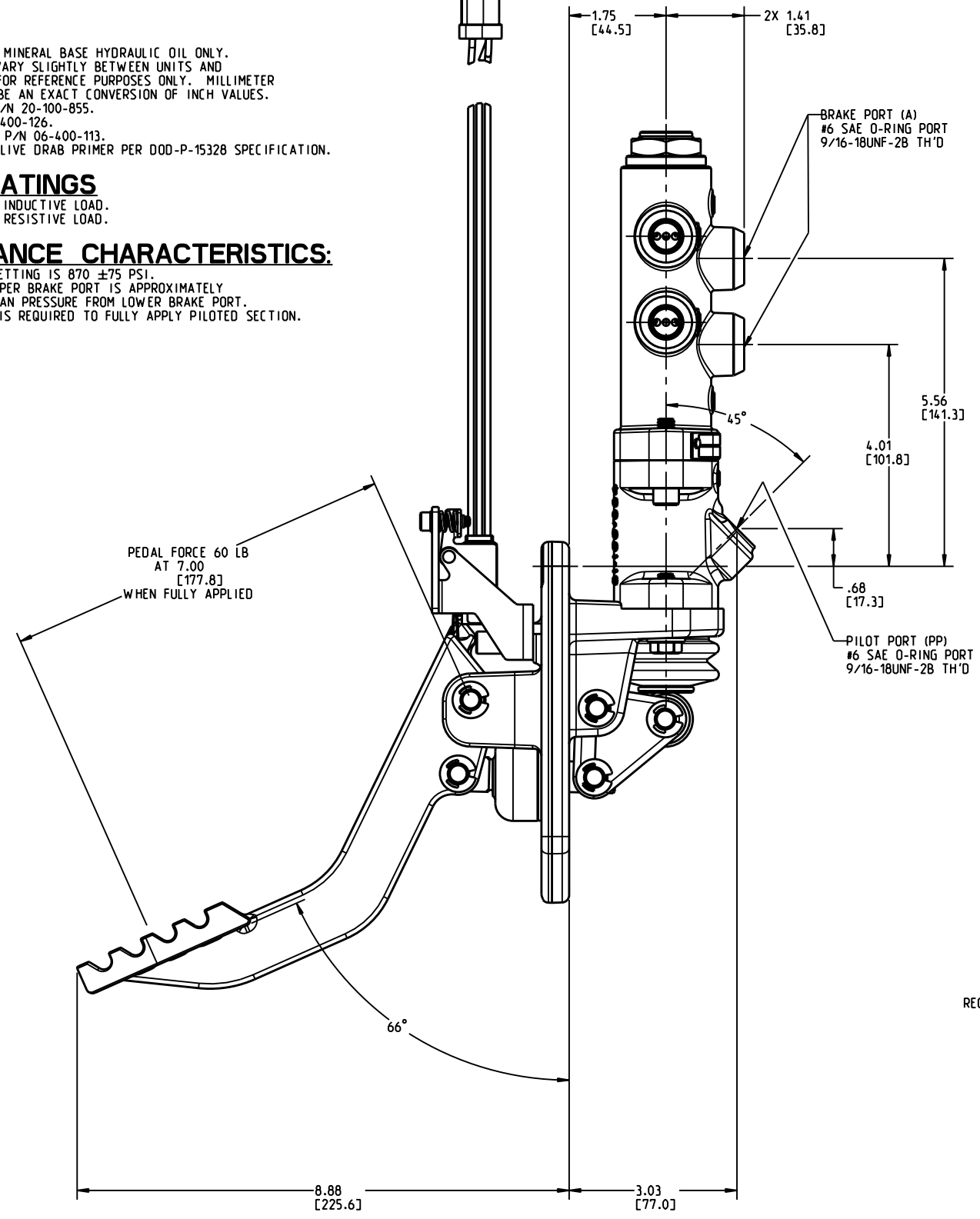

INCH
[MILLIMETER]



COMPONENT AND SYSTEM RECOMMENDATIONS MADE BY MICO, INC ARE BASED ON INFORMATION SUPPLIED BY POTENTIAL USER AND/OR SYSTEM DESIGNER. THE POTENTIAL USER AND/OR DESIGNER MUST MAKE FINAL ACCEPTANCE AND APPROVAL OF COMPONENTS AND SYSTEM AFTER TESTING PERFORMANCE ON AN ACTUAL APPLICATION FOR WHICH SYSTEM WAS DESIGNED.

MICO, INC CLAIMS PROPRIETARY RIGHTS TO THE MATERIAL DISCLOSED IN THIS DOCUMENT. THIS DOCUMENT IS PROVIDED IN CONFIDENCE AND MAY NOT BE REPRODUCED OR DISCLOSED WITHOUT WRITTEN PERMISSION FROM MICO, INC. COPYRIGHT MICO, INC. ALL RIGHTS RESERVED.

SCALE 0.375	TITLE PEDAL MODULATING VALVE WITH SWITCH		
DWN MAP 3-Aug-06	APVD PROD ENGRG LJ 04-AUG-2006	SIZE B	DRAWING NUMBER 06-464-972
X NO CRT 7745	APVD ENGRG JC 03-AUG-2006	B	REV B
			CUSTOMER COPY